

**HOBART**701 S Ridge Avenue, Troy, OH 45374  
1-888-4HOBART • www.hobartcorp.com**2912  
SLICER****HOBART****STANDARD FEATURES**

- Variable Six-Speed Automatic Carriage with Front Mounted Controls
- Home Position Start
- Close To Stop
- Gauge Plate Interlock
- Carriage System Interlock
- No Volt Release
- Exclusive Tilting, Removable Carriage System
- CleanCut™ Knife
- Top Mounted Borazon Stone Sharpener
- Hobart Poly V-Belt Drive System
- Sanitary Anodized Aluminum Base
- Double-Action Indexing Cam
- Permanently Mounted Ring Guard
- Heavy Gauge Stainless Steel Knife Cover
- Lift Lever
- Removable Rear Deflector
- ½ H.P. Knife Drive Motor
- Nylon Carriage Roller
- Electroless Nickel Plated Single Slide Rod with Reservoir Wick
- Stainless Steel Carriage
- Ergonomic Style Handle
- Low Fence

**MODEL**

- 2912 – Smart Feature Automatic Slicer

**ACCESSORIES**

- Low Fence
- High Fence
- Food Chute
- Heavy Meat Grip
- Tall Legs
- Product Tray

Specifications, Details and Dimensions on Inside and Back.

**2912 SLICER**

## SOLUTIONS / BENEFITS

### Variable Six-Speed Automatic Carriage with Front Mounted Controls

- Improved yield, labor savings
- Greater flexibility for all slicing needs
- Six speed choices for 28, 33, 38, 42, 47, and 52 strokes per minute

### Home Start Position

- Maximizes yield
- Carriage must be in "home position" before the slicer will start

### Close To Stop

- Convenience, labor savings, energy savings
- Closing of gauge plate turns off the slicer

### Gauge Plate Interlock

- Supports use of proper cleaning procedures, easier to clean
- Gauge plate must be closed to remove carriage for cleaning and cannot be opened when removed

### Carriage System Interlock

- Will not tilt away or remove if gauge plate indicator is not closed

### No Volt Release

- Protects against unintentional starting of slicer
- Slicer must be restarted if power fails or slicer is unplugged

### Exclusive Tilting, Removable Carriage System

- Reduces labor, improves sanitation
- Tilt design allows for ease of midday cleaning
- Removable for complete cleaning and sanitation procedures

### CleanCut™ Knife

- Reduced cost of ownership, improved yield
- Thin edge design improves yield
- Super alloy edge lasts longer
- Fewer and shorter sharpenings required

### Top Mounted Borazon Stone Sharpener

- Ease of use, improved sanitation, reduced costs
- Single action sharpens and hones in just five seconds
- Removable and submersible for easy cleaning and sanitation
- Lifetime guaranteed Borazon sharpening stones provide maximum performance with reduced maintenance costs

### Poly V-Belt Drive System

- Performance, durability, reduced maintenance
- Patented design extends belt life while producing optimum slicing results
- Quieter operating slicer

### Sanitary Anodized Aluminum Base

- Improved sanitation, labor savings
- One piece base protects against possible growth of bacteria
- No cracks/crevices or bolt holes where product can lodge and bacteria may grow
- Easy cleanup and durable finish

### Double-Action Indexing Cam

- Increases reliability, easier to use, increased yield
- The first full revolution of the indexing knob provides precise control for shaving, chipping and thin slicing
- The second revolution opens the gauge plate quickly for thicker slicing
- Gauge plate holds position for consistent, precision slicing

### Permanently Mounted Ring Guard

- Protection
- Protects knife during operation and cleaning

### Heavy Gauge Stainless Steel Knife Cover

- Durability, ease of use, sanitation
- Twelve-gauge stainless steel maintains shape to ensure consistent fit
- Spring loaded knob for quick removal and easy cleanup
- One piece design for simplistic usage

### Lift Lever

- Improved sanitation, ease of use
- Props machine for easy cleaning underneath slicer

### Removable Rear Deflector

- Improved sanitation, ease of use
- Allows access for thorough cleaning
- No tools required means easy removal during cleaning

### ½ H.P. Knife Drive Motor

- Durability, performance
- Reserve power runs at 400 rpm for optimum results

### Nylon Carriage Roller

- Performance
- Easy movement for manual operation

### Electroless Nickel Plated Single Slide Rod with Reservoir Wick

- Performance, durability, lower maintenance
- Smooth operation with continuous lubrication of carriage rod
- Resistant to rust

### Stainless Steel Carriage

- Improved sanitation, durability
- Maximum sanitation with minimum cleanup time
- Corrosion resistant, impact resistant

### Ergonomic Style Handle

- Operator satisfaction
- Comfortable manual operation

### Meat Grip Options

- Multiple choices for improved yield and consistency
- Front meat grip standard
- Heavy front meat grip available



701 S Ridge Avenue, Troy, OH 45374  
1-888-4HOBART • www.hobartcorp.com

# 2912 SLICER

## SPECIFICATIONS

**VARIABLE SIX-SPEED AUTOMATIC CARRIAGE WITH FRONT MOUNTED CONTROLS:** Choice of six speeds - 28, 33, 38, 42, 47, 52 strokes per minute. Carriage can be disengaged from power drive whether slicer is in operation or not. Automatic engagement and speed selector controls located in front of machine. Speed can be changed with slicer motor on or off. Carriage driven by DC gear-reduction motor and 4 bar synchronous linkage.

**HOME POSITION START:** Home-start ensures carriage is in a convenient position before starting the slicer.

**CLOSE TO STOP:** After slicing, a quick turn of the index knob to the closed position turns off the slicer.

**GAUGE PLATE INTERLOCK:** Gauge plate interlock protects knife edge when indicator is at zero.

**CARRIAGE SYSTEM INTERLOCK:** Carriage will not tilt away or remove if gauge plate indicator is not closed.

**NO VOLT RELEASE:** In the event of power loss, slicer must be restarted before operation can continue.

**TILTING REMOVABLE CARRIAGE SYSTEM:** Positive angle carriage design enables operator to slice without manual feed. The stainless steel carriage system tilts back easily for midday cleaning and is removable for thorough cleaning and sanitation procedures. The carriage has 12½" manual travel.

**CLEANCUT™ KNIFE:** Another Hobart exclusive, the knife is constructed of 304L stainless steel and high performance super alloy. Knife is protected by a permanently mounted ring guard with integrated product deflector. The stainless steel knife cover provides easy access for cleaning. Gauge plate protects knife edge when indicator is closed. Knife cover is quickly removed with a quarter turn of the spring loaded locking knob.

**TOP MOUNTED BORAZON STONE SHARPENER:** One lever operation utilizing two Borazon stones to sharpen and hone in five seconds. Removable and top mounted. When sharpener is removed for cleaning, knife edge is shielded. Borazon stones have lifetime guarantee.

**HOBART POLY V-BELT DRIVE SYSTEM:** Knife is driven by a Hobart Poly V belt and runs at 400 rpm for optimal performance.

**SANITARY ANODIZED ALUMINUM BASE:** One-piece base protects against possible growth of bacteria. All surfaces are durable and smooth, presenting no holes or crevices in which food can lodge.

**DOUBLE-ACTION INDEXING CAM:** First revolution of index cam for precision slicing; second revolution for thicker slicing selection. Indexing cam holds true to setting during slicing operation.

**PERMANENTLY MOUNTED RING GUARD:** Permanently mounted ring guard with integrated product deflector protects knife.

**HEAVY GAUGE STAINLESS STEEL KNIFE COVER:** One piece design made of 12 gauge stainless steel, durable to maintain shape and ensure consistent fit. Spring loaded for quick removal and replacement.

**LIFT LEVER:** Lift lever facilitates raising slicer to tilted position for cleaning beneath the machine.

**REMOVABLE REAR DEFLECTOR:** No tools are required for removal of the deflector for thorough cleaning of the slicer.

**KNIFE MOTOR:** ½ H.P., permanently lubricated ball bearings. Single phase capacitor-start, induction run.

**ELECTROLESS NICKEL PLATED SINGLE SLIDE ROD WITH RESERVOIR WICK:** Transport slide rod is E-Nickel electroless plated. Slide rod bearings feature an oil reservoir/oil wick.

**FINISH:** Stainless steel carriage, gauge plate and knife cover. Anodized aluminum base.

**ERGONOMIC STYLE HANDLE:** Specially designed for ease of use during manual operation.

**MEAT GRIP:** Front mounted grip is high strength thermoplastic. Swings out of way when not in use.

**ELECTRICAL SPECIFICATIONS:** 120/60/1 – U L Listed. Also available in 100/50/60/1, 240/60/1 (3 amps) and 230/50/1 (3 amps) – not submitted for U L Listing.

**SWITCH:** Moisture protected toggle type, operated by a push-pull rod.

**CORD & PLUG:** 6-foot, three-wire power supply cord and plug. Plug not furnished on export models.

**CAPACITY:** The carriage will take food up to 12" in width or 7½" in diameter.

**GAUGE PLATE:** Gauge plate is a heavy aluminum casting with ribbed laminated stainless steel face for smooth feeding. Adjustable to cut any thickness of slice up to 1".

**WARRANTY:** All parts and service coverage for one year including knife. Lifetime guarantee on Borazon stones in the sharpening system.

**WEIGHTS FOR THE FOLLOWING ITEMS:** Tubular Chute 9.1 lbs.; Swing Arm .61 lbs.; Heavy Front Meat Grip 2.76 lbs.; Heavy Handle 2.7 lbs.; Standard Meat Grip 2.34 lbs.

**WEIGHT:** Shipping 182 lbs., Net 140 lbs.

# 2912 SLICER

# HOBART

701 S Ridge Avenue, Troy, OH 45374  
1-888-4HOBART • www.hobartcorp.com

## DETAILS AND DIMENSIONS

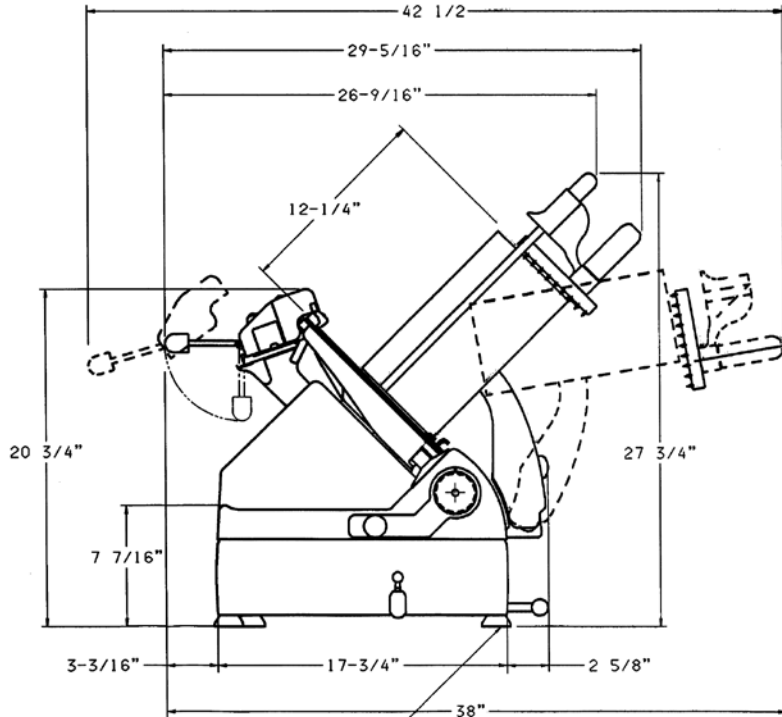

### WARNING

ELECTRICAL AND GROUNDING CONNECTIONS MUST COMPLY WITH THE APPLICABLE PORTIONS OF THE NATIONAL ELECTRICAL CODE AND/OR OTHER LOCAL ELECTRICAL CODES.

WHEN IN CLEANING POSITION  
LEG 5" OFF GROUND  
PIVOTED BY OTHER LEG

11-3/4"  
KNIFE DIA.

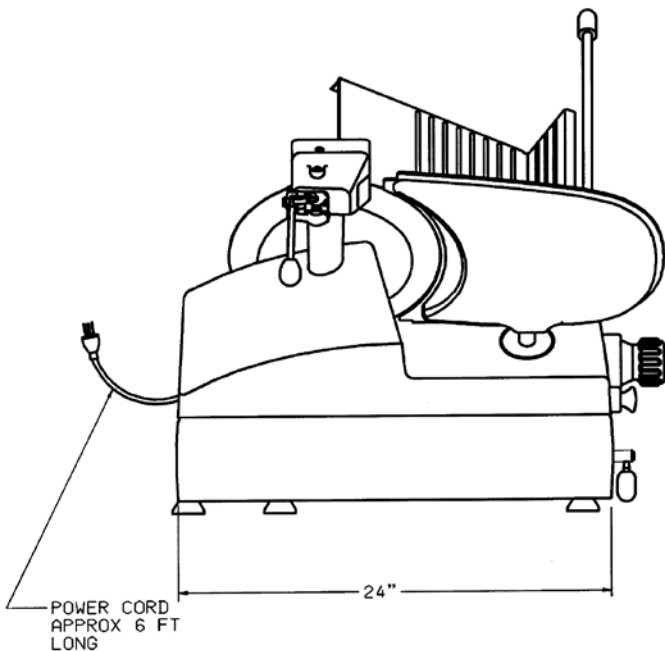
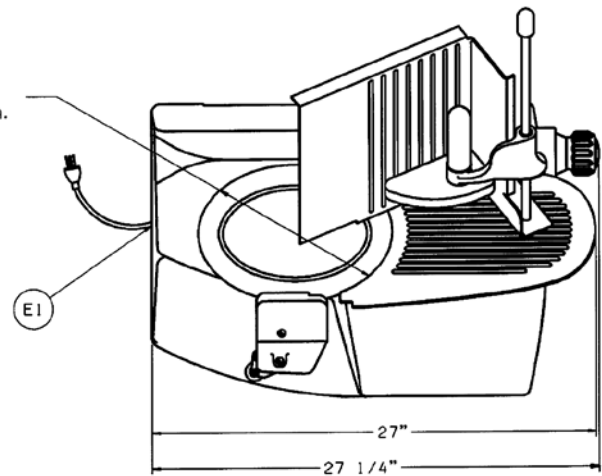

### LEGEND

E1-ELECTRICAL CONNECTION,  
APPROX 6 1/2" ABOVE  
COUNTER TOP

As continued product improvement is a policy of Hobart, specifications are subject to change without notice.