



Project _____
 AIA # _____ SIS # _____
 Item # _____ Quantity _____ C.S.I. Section 114000

RMC SERIES MILK COOLER 8 CRATE CAPACITY MODELS



Model Shown - RMC49D4

STANDARD PRODUCT FEATURES

- Energy Efficient Refrigeration System, Using R290 Refrigerant
- Thermostatic Expansion Valve Metering Device
- Stainless Steel Exterior & Interior
- Electronic Control
- Top Mounted Removable Refrigeration System
- Forced Air Refrigeration System
- Accommodates (8) 13" x 13" Crate(s) or (4) 13" x 19" Crate(s)
- Single or Double Sided
- Low Access Point
- Sliding Lift Up & Down Door(s)
- Reinforced Cabinet Exterior Bottom
- Durable Caster Rail System for Flexible Positioning
- Heavy Duty Dunnage Racks Protect Cabinet & Promote Airflow
- Lockable Insulated Doors
- Metal Door Handles
- Magnetic Snap-In EZ-Clean Door Gasket(s)
- Floor Drain with Plug
- 9' Cord & Plug Attached
- Set of Four (4) 4" Factory Mounted Adjustable Casters



This unit is listed to the applicable ETL and NSF Standards by an approved NRTL. Consult the factory or unit's data plate for approval information.

AVAILABLE CONFIGURATIONS

Single Access Models

RMC34S4 8 Crate 34" Length, 4" Casters

Double Access Models

RMC34D4 8 Crate 34" Length, 4" Casters

ACCESSORIES & OPTIONS (*field installed)

- Set of (4) 6" Adjustable Casters
- MCACC-BUMPER, Bumper Corner Guard Kit (4)

Approved by _____ Date _____ Approved by _____ Date _____

MODELS

Single Access Model: RMC34S4
 Double Access Model: RMC34D4

Single Access Models

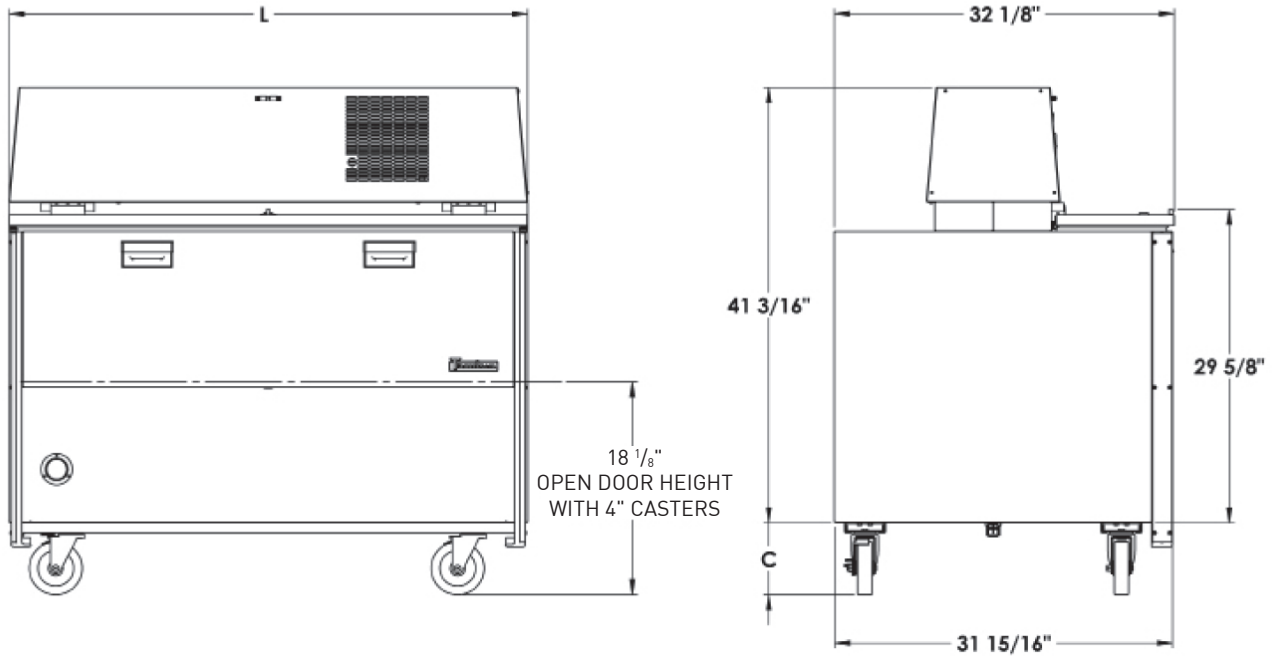

Double Access Models

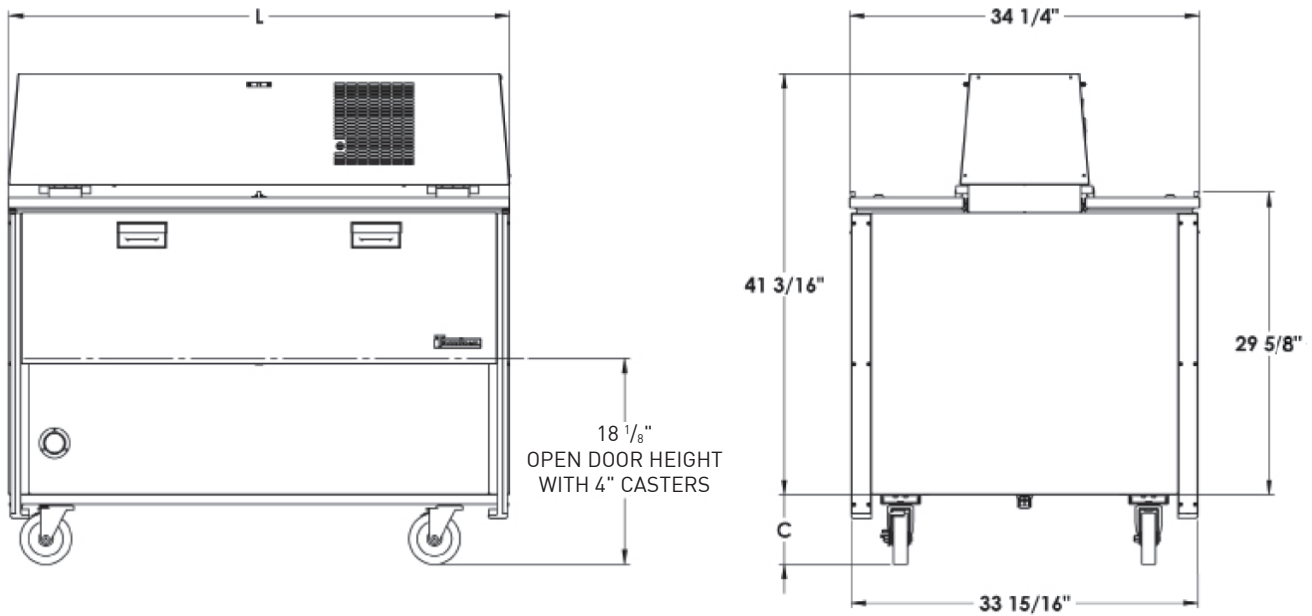



RMC SERIES

MILK COOLER

8 CRATE CAPACITY MODELS

MODELS

Single Access Model: RMC34S4
 Double Access Model: RMC34D4

MODELS	RMC34
DIMENSIONAL DATA	
Net Crate Capacity 13 x 13 in. ¹	8
Net Crate Capacity 13 x 19 in. ¹	4
Length -Overall in.	34 (86.4 cm)
Depth-Single Cabinet Only in.	32 1/8 (81.6 cm)
Depth-Double Cabinet in.	34 1/4 (87 cm)
Height-Overall on 4" Casters	46 (116.8 cm)
Net Weight uncrated lbs. (kg)	395 (179)
ELECTRICAL DATA (NEMA 5-15P attached)	
Voltage	115/60/1
Single & Dual Access Full Load Amperes kWh/Day ²	2.3 1.88 kWh/Day
Single Access Cabinet Volume	11.72
Double Access Cabinet Volume	12.46
REFRIGERATION DATA	
Refrigerant	R-290
Refrigerant Amount oz.	2.5 (70.9 g)
BTU/HR ³ H.P.	1650 1/5 H.P.

NOTE:

- * Figures in parentheses reflect metric equivalents.
- 1. Net Capacity cu. ft.
- 2. kWh/Day = Kilowatt usage per 24 hours.
- 3. Based on a 90°F ambient and 20°F evaporator.

When ordering please specify: Voltage, Hinging, and Options.

Equipped with one NEMA 5-15P Plug



EQUIPMENT SPECIFICATIONS

CONSTRUCTION, HARDWARE, INSULATION

Cabinet exterior and interior is constructed of stainless steel. Interior sides, back and front are also stainless steel. The exterior cabinet bottom is constructed of stainless steel.

Gasket profile and material simplify cleaning and increase overall gasket life.

Both the cabinet and doors are insulated with non-CFC, foamed in place polyurethane.

DOOR/ACCESS

Front sliding protects gasket(s). Lockable lift up top access door.

REFRIGERATION SYSTEM

A balanced, top mounted side and front and rear breathing, refrigeration system using environmentally friendly, low GWP R-290 refrigerant is provided. It features an air-cooled hermetic compressor, thermostatic expansion valve metering device, and a forced air evaporator coil. An 9' cord and plug is provided. Standard operating temperature is 34° to 38°F (1.1° to 3.3°C).

CONTROLLER

An electronic digital control is supplied standard. It includes a 3-Digit LED display, and a Fahrenheit or Celsius temperature scale display capability.

INTERIOR/DUNNAGE RACKS

Heavy duty removable dunnage racks protect cabinet and promote airflow.

WARRANTIES

Both a six year parts and labor warranty and seven year compressor parts warranty.

CONTINUED PRODUCT DEVELOPMENT MAY NECESSITATE SPECIFICATION CHANGES WITHOUT NOTICE.