

MANUAL FLYWHEEL SLICING MACHINE

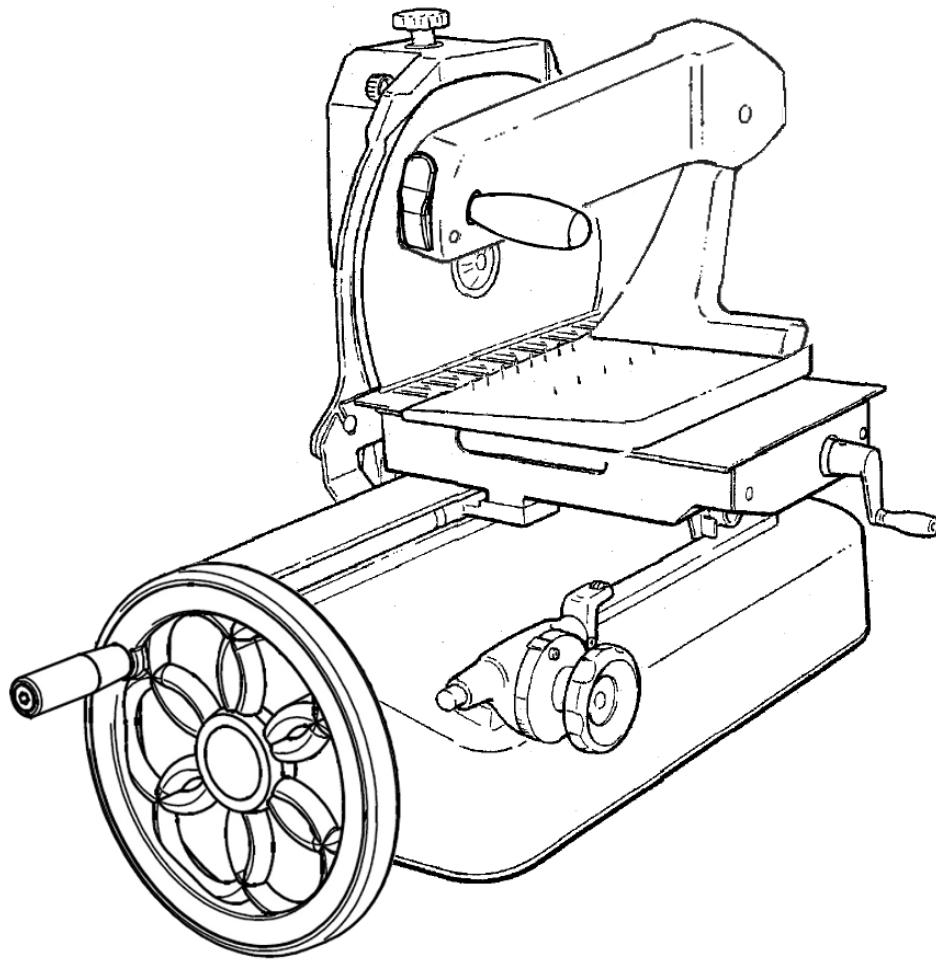

Instruction for use, installation and maintenance

Model 330M

LIST OF CONTENTS

	Page
1. INTRODUCTION	2
1.1 PURPOSE OF THE MANUAL	2
1.2 KEEPING THE MANUAL	2
1.3 USE OF THE MACHINE	2
2. GENERAL INFORMATION	2
2.1 MACHINE LIMITS, SAFETY, REGULATIONS	2
2.2 GUARANTEE AND MANUFACTURER'S RESPONSIBILITY	4
2.3 USER'S OBLIGATIONS	6
2.4 PLATES	6
3. TECHNICAL CHARACTERISTICS	7
3.1 MAIN TECHNICAL DATA	7
3.2 PRODUCTS THAT CAN BE SLICED	8
3.3 PRODUCTS THAT CANNOT BE SLICED	8
4. DESCRIPTION	8
4.1 UNPACKING	8
4.2 MAIN COMPONENTS	12
4.3 GENERAL DESCRIPTION	13
5. INSTALLATION	14
5.1 INSTALLATION OF THE MACHINE	14
5.2 COMMAND DESCRIPTION	14
6. USING THE SLICING MACHINE	15
6.1 LOADING THE GOODS	15
6.2 CUTTING THE GOODS	15
6.3 CLEANING THE SLICING MACHINE	16
7. MAINTENANCE AND REPAIRS	17
7.1 GENERAL INFORMATION	17
7.2 SHARPENING THE BLADE	18
7.3 LUBRICATING THE GUIDE BARS OF THE CARRIAGE AND OVERPLATE	19
7.4 ADJUSTING THE CHAIN	19
7.5 ADJUSTING THE BEVEL GEAR PAIR	20
8. DISMANTLING THE SLICING MACHINE	20

The manual is made up of 17 progressively numbered pages.

The contents are divided into progressively numbered paragraphs, if in any doubt about the contents and for any further explanation contact the manufacturer or the authorised technical assistance, stating the paragraph number of the pertinent subject.

1. INTRODUCTION

1.1 PURPOSE OF THE MANUAL

This publication contains all the information necessary for the installation, use and maintenance of the manual flywheel slicing machines to be used for food, with circular blade, models 330M.

The purpose of this manual is to allow the user, above all the direct user, to take every precaution and arrange all human and material means necessary for a safe and lengthy use of these machines.

1.2 KEEPING THE MANUAL

This manual must be given to the person who will use and maintain the machines and this person will keep the manual in a safe and dry place, ready to be used.

We recommend that a copy be kept on file.

For any correspondence with the manufacturer or authorised personnel, please refer to the information on the plate and the machine serial number.

The manual must be kept for the entire life of the machine and in case of need (ex. any damage to even a part of the manual that makes consulting it difficult) the user must acquire a new copy exclusively from the manufacturer.

The user must let the manufacturer know the address of any new owner of the machine.

1.3 USE OF THE MACHINE

The use and configurations of the machine are the only ones allowed by the manufacturer; do not try to use the machine differently from the indications.

The machines are to be used for cutting only food products of the type and size indicated in the following paragraphs.

The manufacturer declines all responsibility derived from an improper use or use by personnel who has not read and fully understood the contents of this manual; changes and/ or repairs carried out on one's own; the use of spare parts that are not original or not specific for the type of machine.

For any explanation or doubts on the contents of this manual, please contact immediately the manufacturer or an authorised technical assistance service and quote the paragraph number of the required subject.

2. GENERAL INFORMATION

2.1 MACHINE LIMITS, SAFETY, REGULATIONS

The machine has been designed and made to slice food products of the type and size as indicated in paragraphs 3.2, 3.3 and 3.4.

Environmental conditions for using the machine

The operating environment must have the following characteristics:

-Temperature from -5°C to +40 °C

-Relative humidity max. 95%

The machine cannot be used in open areas and/ or exposed to atmospheric agents and in places with fumes, smoke or corrosive and/ or abrasive dust, with the risk of fire or explosion and in any case where the use of antideflating components are prescribed.

General safety regulations

The slicing machine must be used only by personnel who has carefully read the contents of this manual.

The operators must be over 18 years of age, in perfect mental and physical conditions, have the right attitude and capacity (with the necessary knowledge for manoeuvring and normal maintenance of simple mechanical and electrical components).

For a safe use of the machine follow the instructions below:

- Install the machine according to the instructions in the paragraph "Installation";
- Install the machine so that it is far from people who must not use it, especially children;
- Do not be distracted while using the machine;
- Do not wear loose clothing or open sleeves, if necessary use headgear to keep hair out of the way;
- Do not let anyone come close to the machine while in use;
- Do not remove, cover or change the plates that are on the machine and, if they are damaged, replace them immediately;
- Do not remove the protective devices and do not change or exclude the mechanical protective devices;
- Only slice permitted products; do not try to slice any products that are not allowed;
- The area around the machine, where the food is laid and the floor where the operator works must always be kept clean and dry;
- Do not use the machine as a support surface and do not place any object on it that does not pertain to normal cutting operations;
- Immediately stop the machine and call the technical assistance service in the case of anomalous function, suspect of breakages, incorrect movements, unusual noises, etc.;
- Always use gloves that are resistant to cutting and tearing for the cleaning and maintenance operations;
- The goods to be cut are to be placed on and removed from the sliding overplate only when the plate is completely retracted (far from the blade) and the carriage all the way towards the operator;
- No cutting accessories are allowed unless supplied by the manufacturer;
- For any extraordinary intervention (belt replacement, blade replacement, etc.) please contact the manufacturer or authorised assistance personnel.

2.2 GUARANTEE AND MANUFACTURER'S RESPONSIBILITY

The guarantee of a good function and a complete conformity of the machines, that are to be used accordingly, depends on the correct application of the instructions contained in this manual.

The manufacturer declines all direct and indirect responsibility deriving from:

- **Not following the instructions in the manual;**
- **Persons using the machine who have not read and understood the contents of this manual;**
- **Using the machine so that it does not conform to specific regulations in force in the country of installation;**
- **Unauthorised changes and/ or repairs to the machine;**
- **The use of accessories that are not supplied by the manufacturer and spare parts that are not original;**
- **Outstanding events.**

If the machine is sold or given away, this automatically means that the manufacturer is no longer responsible unless the relative manual accompanies it.

If the machine is transferred to another user in a country with another community language it is the first user's responsibility to supply a correctly translated copy of this manual in the language of the country where the machine will be used.

In the case of transfer of the machine the first user must let the manufacturer know the address of the new user so that he can be reached for any indispensable communications.

The original text of this manual, in the Italian language, it to be considered the sole reference for resolving any interpretative controversy pertaining to translations into community languages.

2.3 USER'S OBLIGATIONS

The user must scrupulously observe the instructions in this manual for the manufacturer's guarantee to be valid and particularly:

- Always respect the limits of the machine;
- Always carry out a constant and diligent maintenance;
- Make sure the persons using the machine are qualified and able to do so, including

the fact that they must have read this manual.

2.4 PLATES

The following plate is installed on the machine:
- manufacturer's identification plate, machine plate, technical data plate; placed on the base, as shown in the figure.

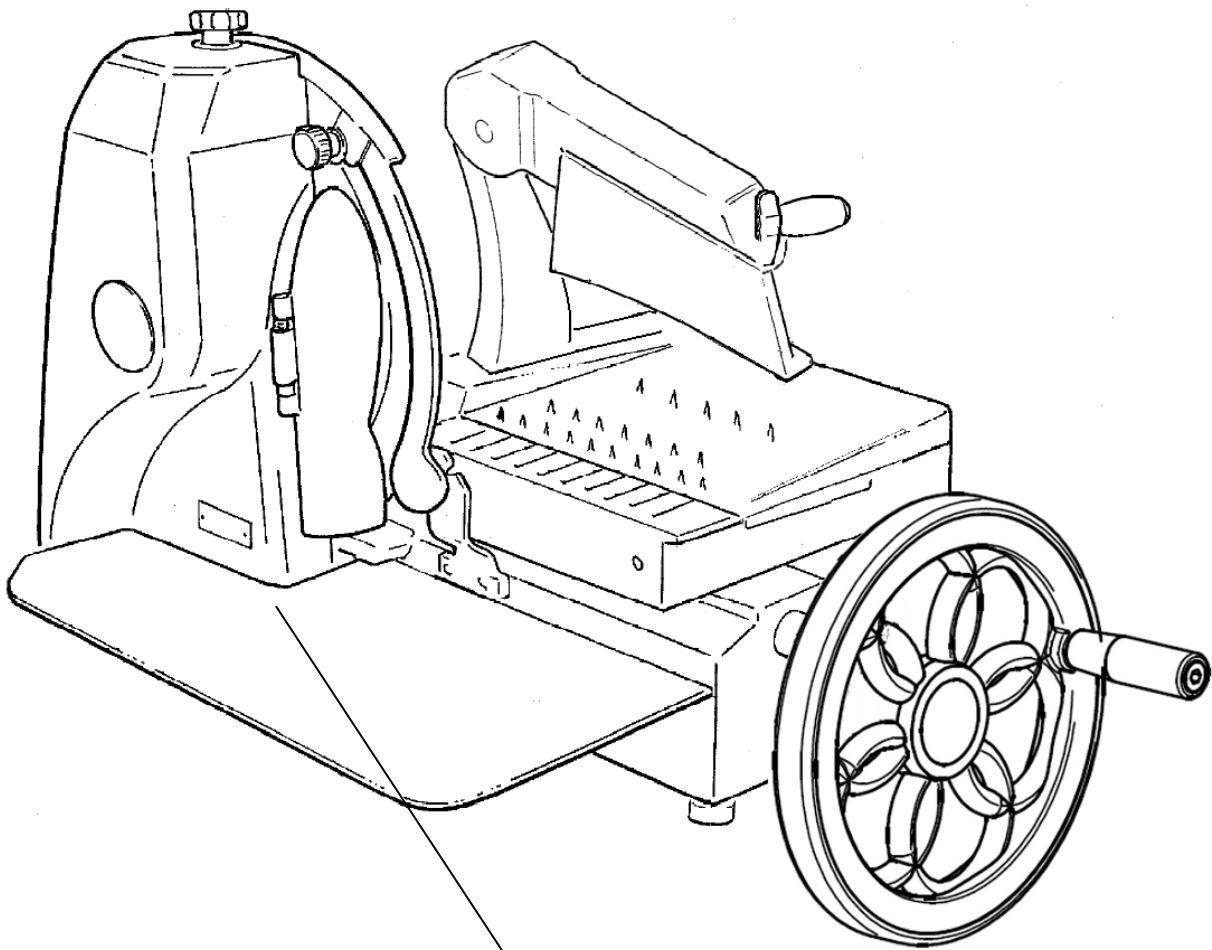

3. TECHNICAL CHARACTERISTICS

3.1 MAIN TECHNICAL DATA

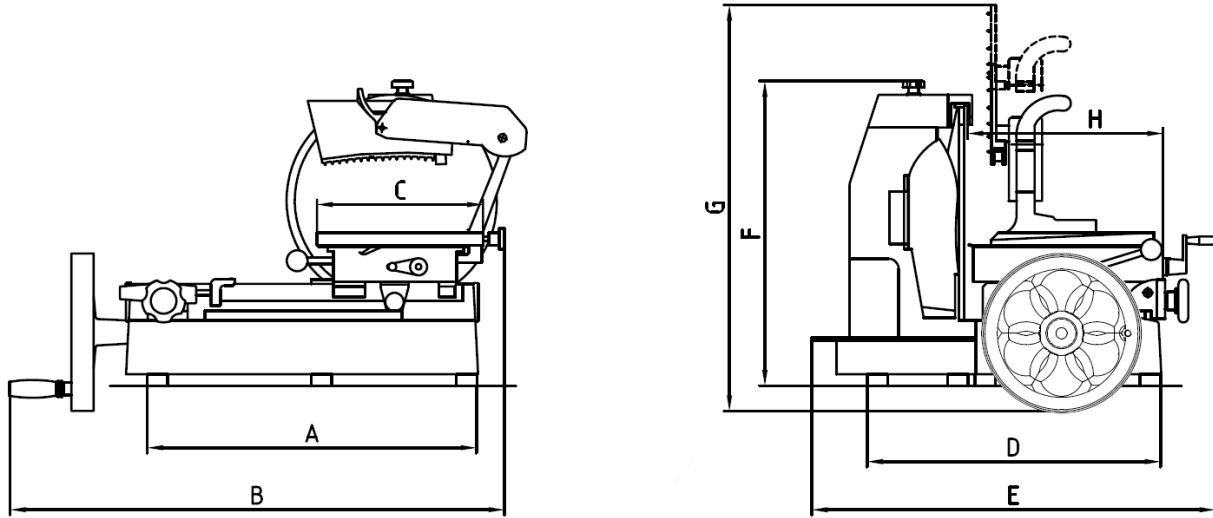

Rif.	Detail	mm
A	Feet distance	630
B	Distance beginning carriage movement/ blade cover	970
C	Max. distance beginning/ end movement	970
D	Feet distance	560
E	Max. width distance	800
F	Height	570
G	Max. height distance	630
H	Table length	290
I	Table width	380

Blade diameter	Carriage movement	Thickness adjuster	Cut's capacity	Net weight
∅ mm 330	mm 280	mm 0-3	∅ mm 190 mm 290x190	kg 62

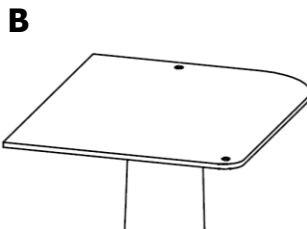
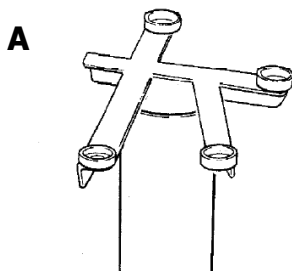

Support column A:

Height 820 mm
 Base 670x650 mm
 Weight 34 Kg

Support column B:

Height 800 mm
 Base 590x450 mm
 Weight 80 Kg

Furnished items and accessories

The following documents and accessories are supplied with the machine, unless otherwise requested:

- Instruction manual for installation, use and maintenance;
- Guarantee certificate;
- Accessories: lubricating oil for carriage guide bars.

3.2 PRODUCTS THAT CAN BE SLICED

The following are products that can be sliced:

- All types of cold cuts (cooked, raw, smoked);
- Boneless meat (cooked or raw at a temperature of no lower than +3 °C);
- Bread and cheeses (those that can be sliced, such as Gruyere, Fontina, etc.).

3.3 PRODUCTS THAT CANNOT BE SLICED

The following are products that cannot be sliced because they could cause damage to people and equipment:

- Frozen foods;
- Deep-frozen foods;
- Food with bones (meat and fish);
- Vegetables;
- Any other product that could be sliced but not meant for consumption.

ATTENTION: Do not try to slice products that are not allowed.

4. DESCRIPTION

4.1 UNPACKING

Check that the packaging is unopened and undamaged; otherwise, immediately inform the forwarding agent or the area agent.

To take the machine out of the packaging proceed as follows:

- Cut and remove the plastic straps;
- Cut the cardboard box at the base which is attached to the pallet;

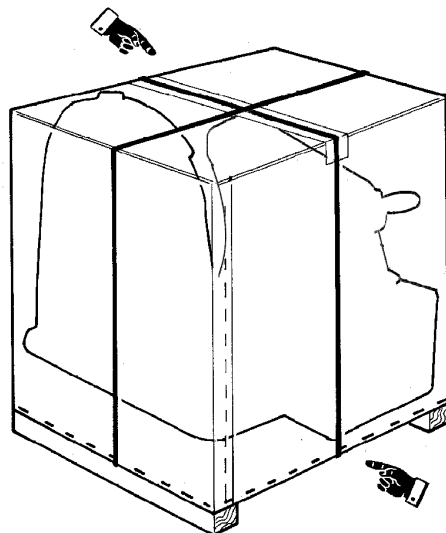

- Lift and remove the cardboard box; take out the polythene bags with the machine flywheel and rubber feet;
- Loosen and remove the two screws that attach the machine to the pallet;

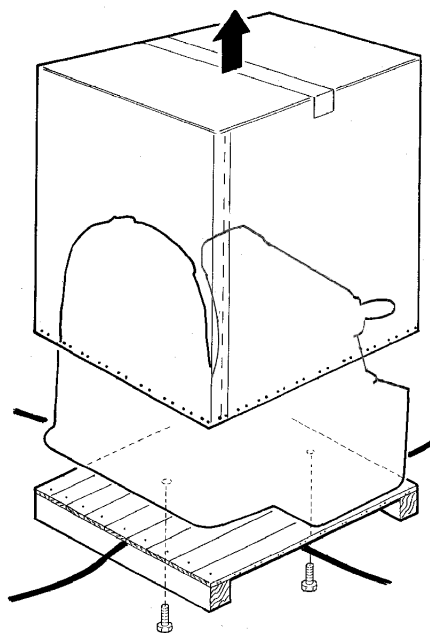

Supply of machine only:

- Lift the machine carefully and insert the four similar rubber feet in the lodgings in the base.
- Put under the head of the machine the other foot (different from the rubber feet) screwing it in the lodging in the head.
- Put the machine in its place of installation.

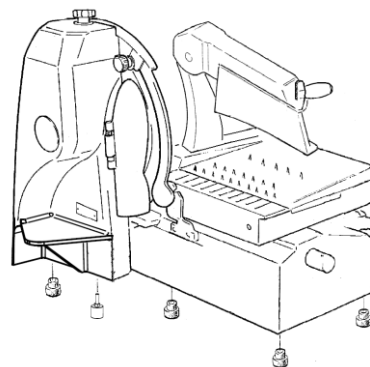

Supply of machine and support column

The machine is supplied with also two washers and two bolts, put together with the feet.

If you have the machine with support column A:

- Lift the machine carefully and insert the following on the base as shown in the figure: position B the rubber holed foot; position A, C and D the normal rubber feet.
- Place the machine on the support column by inserting the feet into the cups; for a correct positioning the support column must be oriented so that the black spot F on the base is on the same side as the machine flywheel shaft.
- Adjust the position on the column regulating the height of the foot E.
- Check that the machine is correctly settled on the column, then lock the machine in place by inserting the screw in the B position going through the cup and rubber foot, do not tighten it too much.

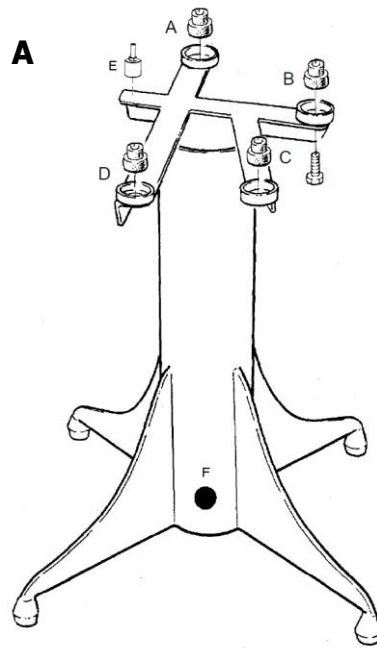

If you have the machine with support column B:

- Lift the machine carefully and pay attention to insert the rubber holed feet in order to have the same shape of the pedestal plate (marked with the arrow) with the same shape of the machine.
- Place the machine on the support column trying to put the holed rubber feet in correspondence of the holes on the plate.
- Adjust the position on the column regulating the height of the foot E.
- Check that the machine is correctly settled on the column, then lock the machine in place by inserting the screws in the holes.
- Eliminate all the packaging (straps, cardboard, polyurethane foam or polystyrene, polyethylene bags, etc.)

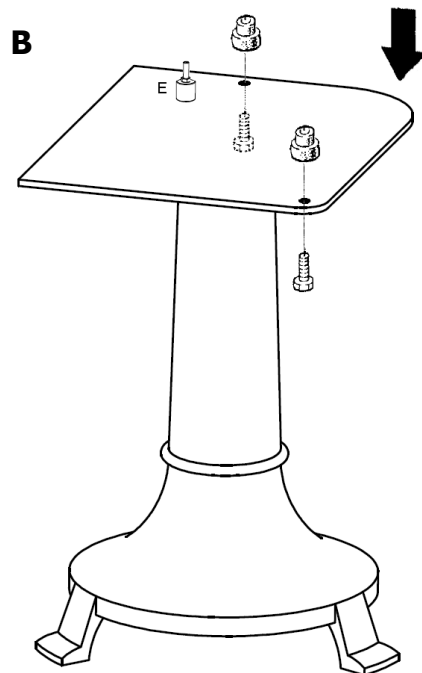

WARNING: The packaging components (plastic straps, cardboard, polyurethane foam) can be thrown away with normal solid wastes and therefore there is no difficulty in disposing of them.

However it is advisable to dispose of products separately (differential collecting) in conformity with the regulations in force for adequate recycling.

DO NOT DISCARD THE PACKAGING PRODUCTS IN THE ENVIRONMENT!

Assembly of the flywheel:

Move the machine carriage all the way towards the operator.

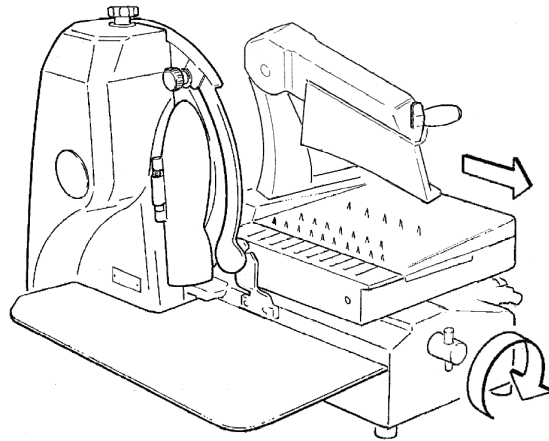

Take out the taper pin from the flywheel shaft.

Attention:
hammer the pin at the tapered end (smaller diameter):

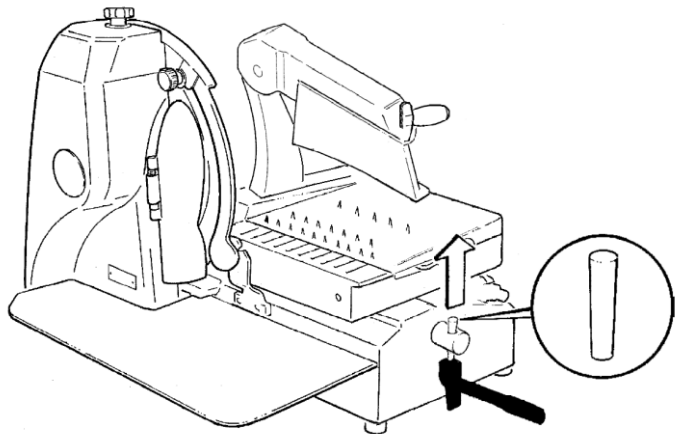

Insert the flywheel so that the manoeuvring handle is at the top and to the left, as shown in the figure, compared to the hole for the taper pin.

Check the correct correspondence of the flywheel shaft sleeve holes.

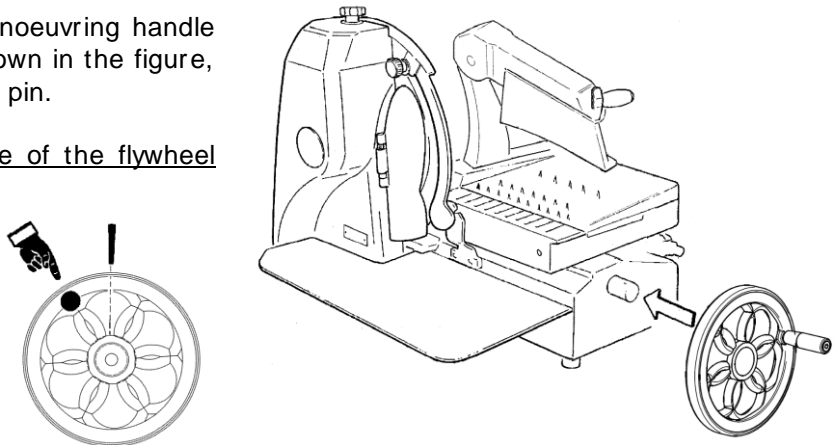

Insert the pin into the sleeve as shown in the figure with the tapered end (smaller diameter) towards the sleeve itself.

Hammer the opposite end of the pin (larger diameter) inserting it all the way.

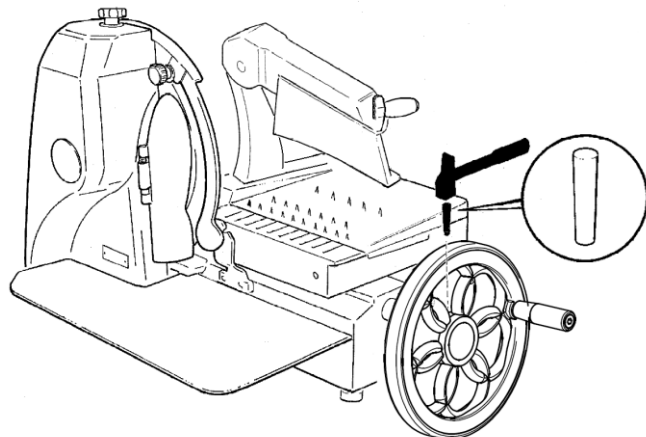

4.2 MAIN COMPONENTS

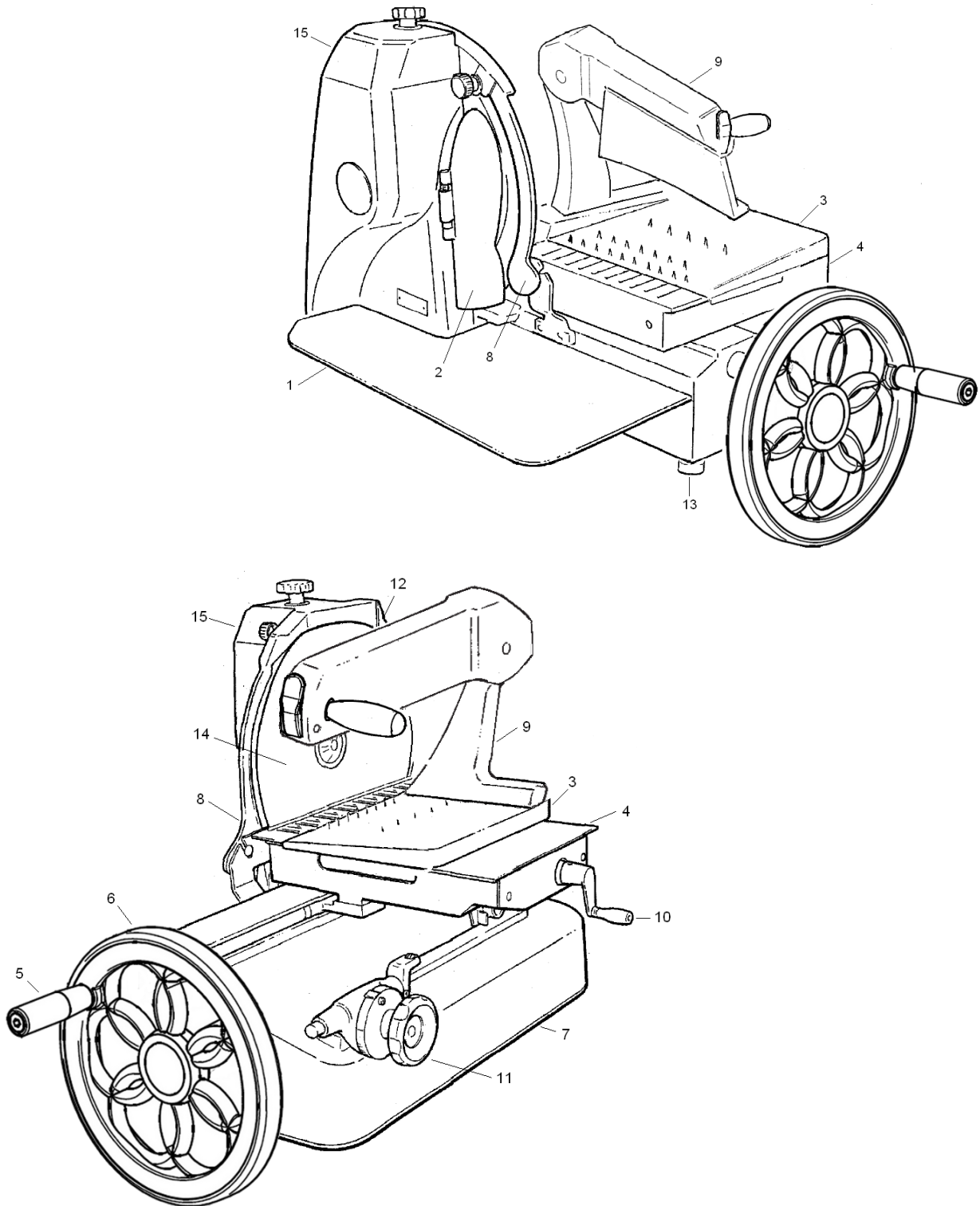

1. Food plate
2. Slice deflector
3. Sliding overplate
4. Carriage
5. Flywheel manoeuvring handle
6. Flywheel
7. Base

8. Blade protection
9. Special handgrip
10. Handwheel overplate advance
11. Regulating knob for slice thickness
12. Blade cover
13. Foot
14. Blade

15. Sharpener

4.3 GENERAL DESCRIPTION

The slicing machine has been designed and made to offer maximum safety when in use, during cleaning and ordinary maintenance; maximum hygiene from the use of inoxidisable materials or adequately protected against oxidation together with an attentive design of all the parts that come into contact with food; maximum cutting precision and capacity together with sturdiness and reliability of the structure.

The machine is essentially made up of a base that holds a circular blade that is vertically mounted and a sliding carriage on bars, parallel to the cutting edge of the blade, which in turn holds a food plate.

The food plate is made up of a base plate and an overplate which slides at right angles to the edge of the blade for slicing the food; the overplate also has an appropriate selfstopping device, which can be regulated in height, to keep the product in its proper place during cutting operations (food press).

Carriage movement and blade rotation are completely manual; by activating rotation of the flywheel with the special handle the carriage is put into motion and at the same time with a chain transmission the blade is turned.

The product is cut during the forward movement of the carriage, parallel to the blade; the thickness of the slice is regulated by a mechanical device which is automatically started every time the carriage comes back, making the sliding overplate transversally towards the blade, with a value which is predetermined by the graduated handwheel.

All the components of the machine are made of a light aluminium alloy, in stainless steel and plastic for food products as according to the sanitary regulations in force.

The machine has a sharpener which is extremely easy and safe to use.

The food plate, sharpener and blade cover can be removed for cleaning.

4.3.1 Risks during use

DO NOT use the machine if you are not in perfect psycho-physical condition and DO NOT let anyone come near during use; concentrate when loading and cutting the product; pay attention!

Only cut products which are allowed; DO NOT try cutting products which are forbidden.

DURING CLEANING, LUBRICATION AND BLADE SHARPENING ALWAYS USE PROTECTIVE GLOVES WHICH ARE RESISTANT TO CUTS AND TEARS.

5. INSTALLATION

5.1 INSTALLATION OF THE MACHINE

If a support column is not used, install the machine on a surface which is level, dry and suitable for the weight of the machine plus the food to be sliced; refer to paragraph 3.1.

Check that there is nothing that can get in the way of the flywheel, carriage movement and food loading.

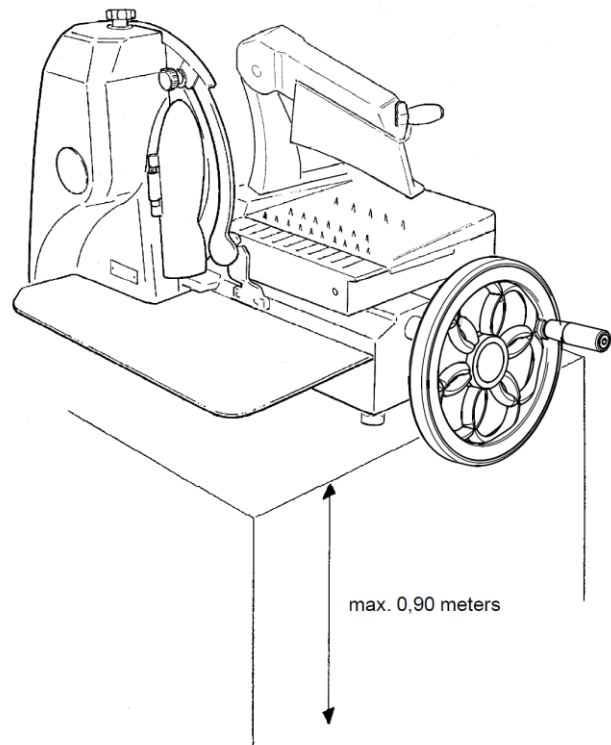

5.2 COMMAND DESCRIPTION

5.2.1 MANOEUVRING FLYWHEEL

The flywheel (1) turned clockwise allows the carriage to be moved with the food plate with simultaneous blade rotation.

5.2.2 REGULATING KNOB FOR SLICE THICKNESS

The thickness of the slice is regulated by turning the graduated scale knob (2) clockwise.

Regulating field: see paragraph 3.2.

5.2.3 OVERPLATE ADVANCE HANDWHEEL

The handwheel (3) allows the overplate with the product to be brought quickly near to the blade after loading it or taken away from the blade after cutting or for small regulations.

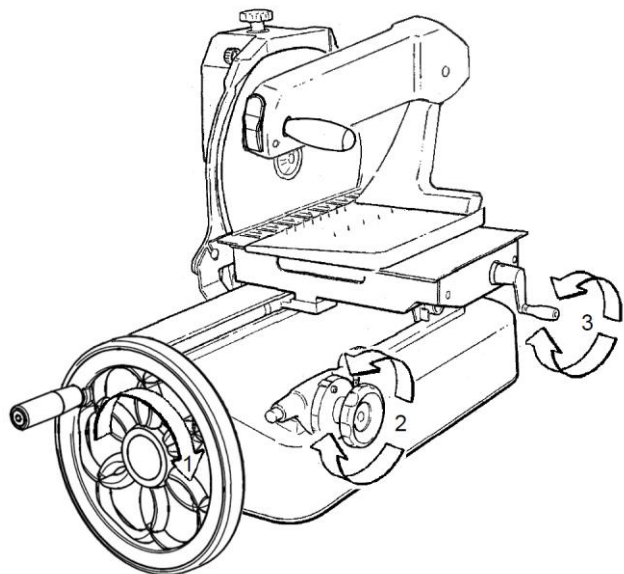

6. USING THE SLICING MACHINE

6.1 LOADING THE GOODS

- Using the flywheel (1) bring the carriage (2) all forward (towards the operator);
- Pull back the sliding overplate (3) completely (away from the blade) using the handwheel (4);
- Place the food to be sliced on the overplate and block it with the food press (5) regulating the height as well;
- Regulate the thickness of the slice by pulling and rotating the knob (6) at the same time, graduated from 0 to 16;
- Bring the overplate with the goods towards the blade by using the rapid advance lever or the handwheel;

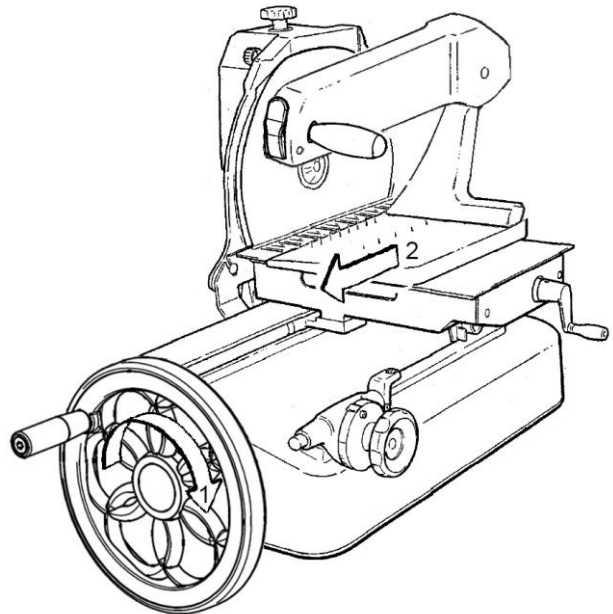

6.2 CUTTING THE GOODS

- Turn the flywheel clockwise (do not turn it counter clockwise, this could seriously damage the machine);
- During the forward movement of the carriage (away from the operator) the goods will go into the blade and the slice, guided by the slice deflector, will fall onto the plate below;
- During the return movement of the carriage (towards the operator) the mechanical device which makes the overplate advance transversally towards the blade will be put into motion, its value pre-determined with the slice thickness regulating knob.

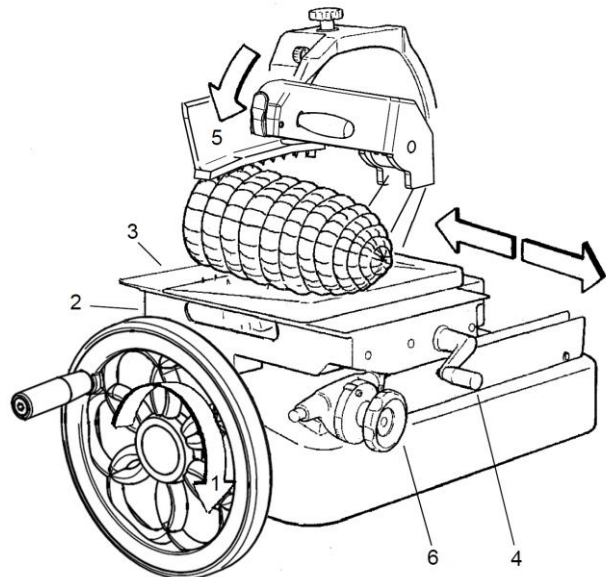

6.3 CLEANING THE SLICING MACHINE

6.3.1 GENERAL INFORMATION

The machines must be properly cleaned at least once a day, if necessary even more. If the machines have not been used for a while they must be cleaned before use as well.

WARNING: Danger of cutting!
Use protective gloves which are resistant to cutting and tearing and concentrate on the job at hand.
PAY CAREFUL ATTENTION!

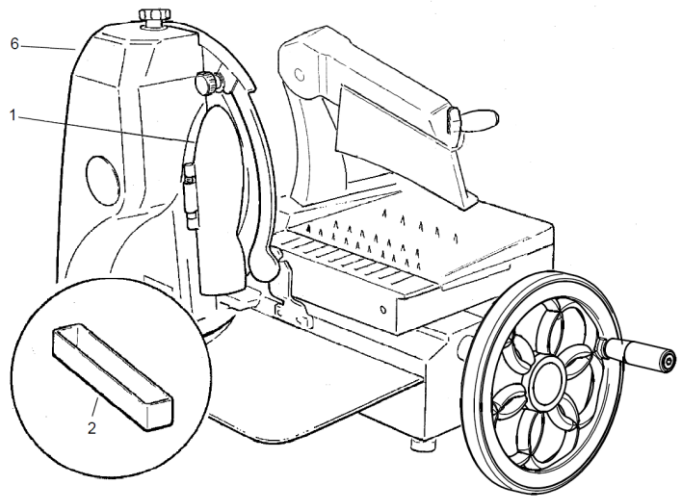

- Open the slice deflector (1);
- Take out the container (2);
- Loosen the knob (3) and lift the sliding overplate (4) with its food press arm;
- Remove the blade cover (5);
- Remove the sharpener (6), raise it using the knob on the top.

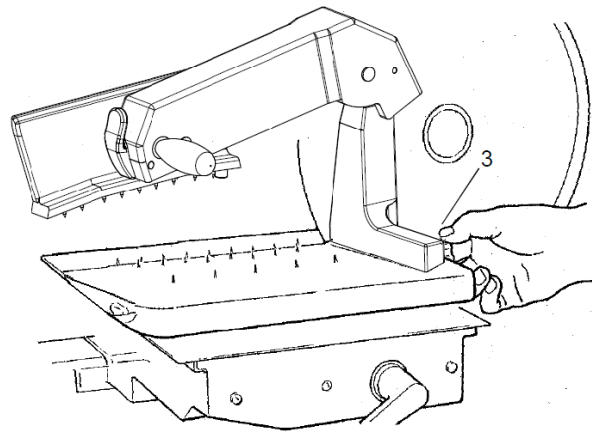

Clean all the disassembled parts, the machine body, etc. only using hot water and a biodegradable foaming detergent for dishes at a temperature of no lower than +30 °C using a soft, spongy cloth and a nylon brush if necessary for the plate and the sharp food press.

Rinse well with a lot of hot clean water only and dry with a soft cloth or a spongy material.

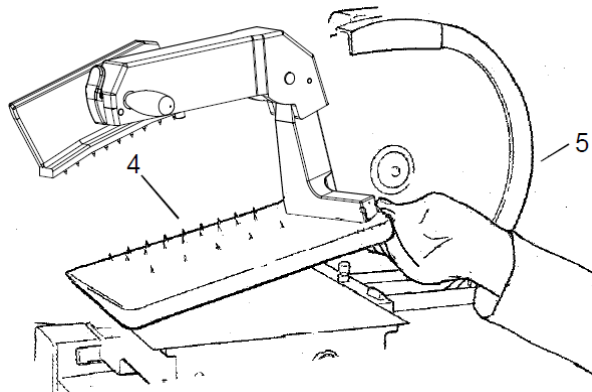

WARNING: DO NOT clean the machine with jets of water or steam or similar.

7. MAINTENANCE AND REPAIRS

7.1 GENERAL INFORMATION

The operator is allowed to carry out the following maintenance:

- **Blade sharpening**, periodically; the interval and length of the sharpening obviously depend on the use of the machine (work times and type of product used).
- **Lubrication of the carriage guide bars and overplate**: weekly;
- **Adjustment of the blade drive chain**: as necessary, see the relative paragraph.
- **Adjustment of the bevel gear pair**: as necessary, see the relative paragraph.

Maintenance to be carried out exclusively by personnel authorised by the manufacturer is as follows:

- **Replacing the blade;**
- **Replacing the sharpener grindstones;**
- **Replacing the chain;**
- **Repairing the structural parts, repairing and/ or replacing components under the base.**

7.2 SHARPENING THE BLADE

Proceed as follows as soon as it is noticed that there is less cutting capacity:

WARNING: Danger of cutting!

Use protective gloves which are resistant to cutting and tearing and concentrate on the job at hand.

PAY CAREFUL ATTENTION!

- Open the slice deflector (1);
- Clean the blade with denatured alcohol or hot water;
- With the knob (2) raise the cover of the sharpener, turn it 180° and lower it again;
- Start the machine (only blade rotation);
- Move the lever (3) from the "0" position to the "sharpening" position and hold it in this position for 10- 15 seconds;
- Move the lever (3) to the "burr" position for 2-3 seconds to remove the sharpening burr;
- Put the lever back to the "0" position and stop the blade movement;
- Raise the cover again, turn it 180° and put it back to its original position;
- Clean the blade and the machine.

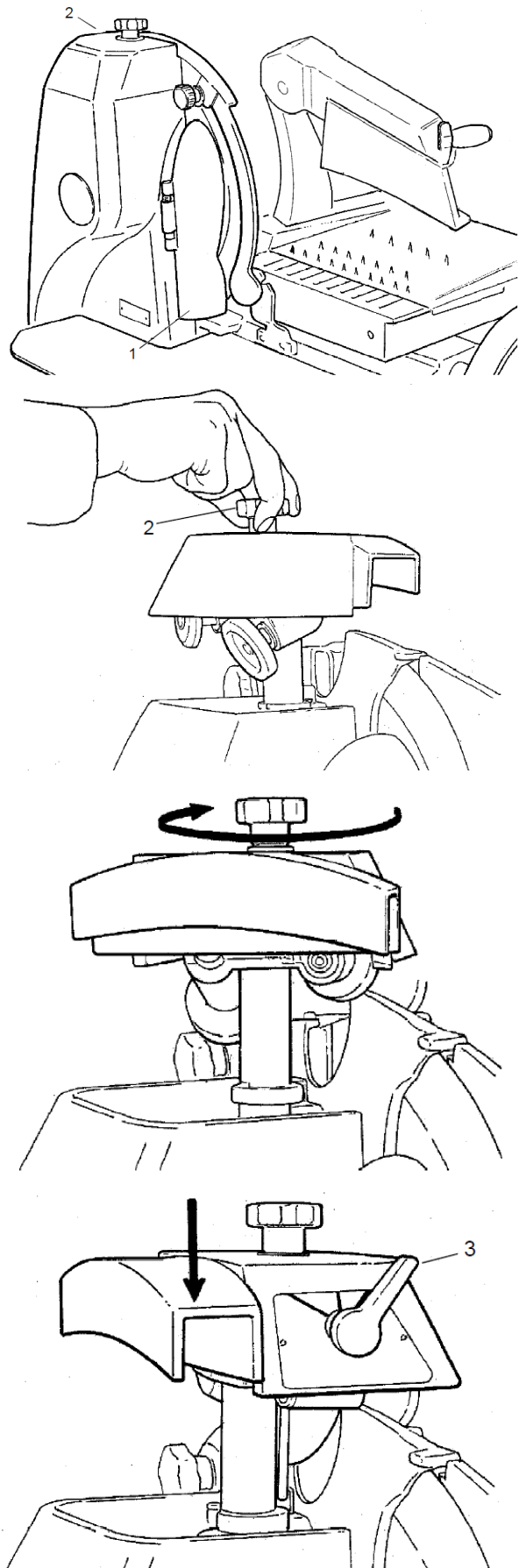

Note: do not insist more than 2-3 seconds with the burring operation so as to avoid damage to the edge of the blade.

7.3 LUBRICATING THE GUIDE BARS OF THE CARRIAGE AND OVERPLATE

- After each cleaning operation of the machine put a few drops of oil in the hole (1) of the plate (2);
- Put a few drops of oil along the sliding bar (3) of the carriage;
- Turn the flywheel briefly.

Note: Only use white Vaseline oil. Do not use vegetable oils.

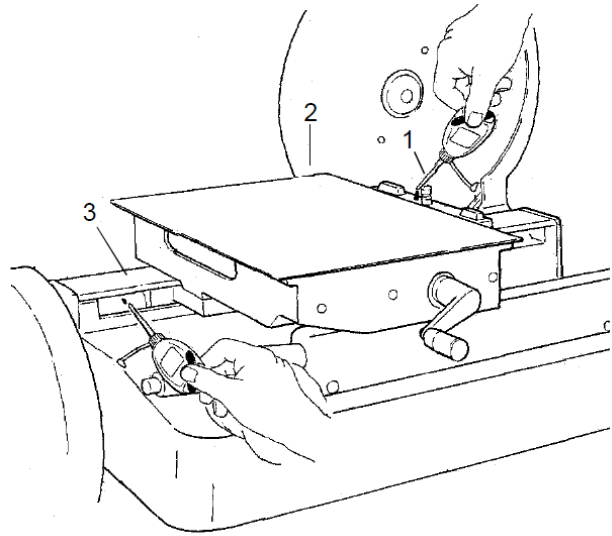

7.4 ADJUSTING THE CHAIN

If you should hear a ticking noise when using the machine check the tension of the blade chain as follows:

- Loosen the two nuts (1) which hold the head (2);
- Raise the head (2) until the required tension of the chain is obtained;
- Tighten the nuts and check.

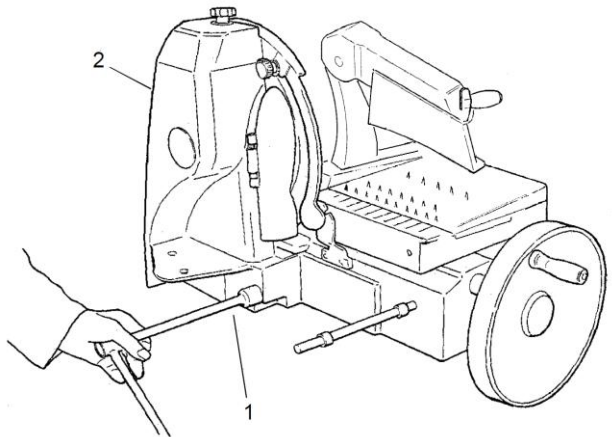

7.5 ADJUSTING THE BEVEL GEAR PAIR

If there is too much play in the flywheel at the start of rotation proceed as follows to eliminate it:

- Remove the cover (1) using a screwdriver;
- Tighten the nut (2) until all play is eliminated;
- Replace the cap (1).

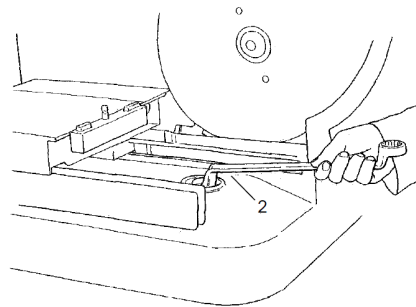
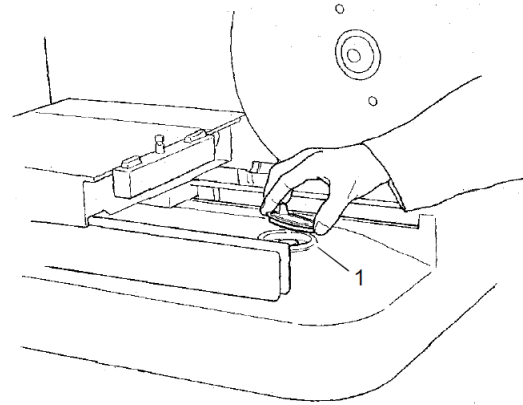

8. DISMANTLING THE SLICING MACHINE

The machines are made up of:

- Aluminium alloy structure;
- Insertions and various in stainless steel;
- Electric parts and wires, etc.;
- Electric motor;
- Plastic materials, etc.

If disassembly and dismantling are to be carried out by a third party, only consult firms that are authorised in the demolition of the above mentioned materials.

If you carry out the dismantling yourself the materials must be separated according to type and consult a specialised firm for their disposal.

Always abide by the regulations in force in your country.

WARNING: In any case it is necessary to consult the manufacturer or qualified personnel authorised by the manufacturer for the removal of the circular blade and subsequent removal of the cutting wire so that it can be disposed of safely.

DO NOT ABANDON SCRAPS WHERE THERE IS FREE ACCESS (THERE SHOULD BE BARRIERS AND SIGNS) BECAUSE THIS CAN BE VERY DANGEROUS FOR PEOPLE, SPECIALLY CHILDREN AND ANIMALS; THE OWNER HAS SOLE RESPONSIBILITY.