

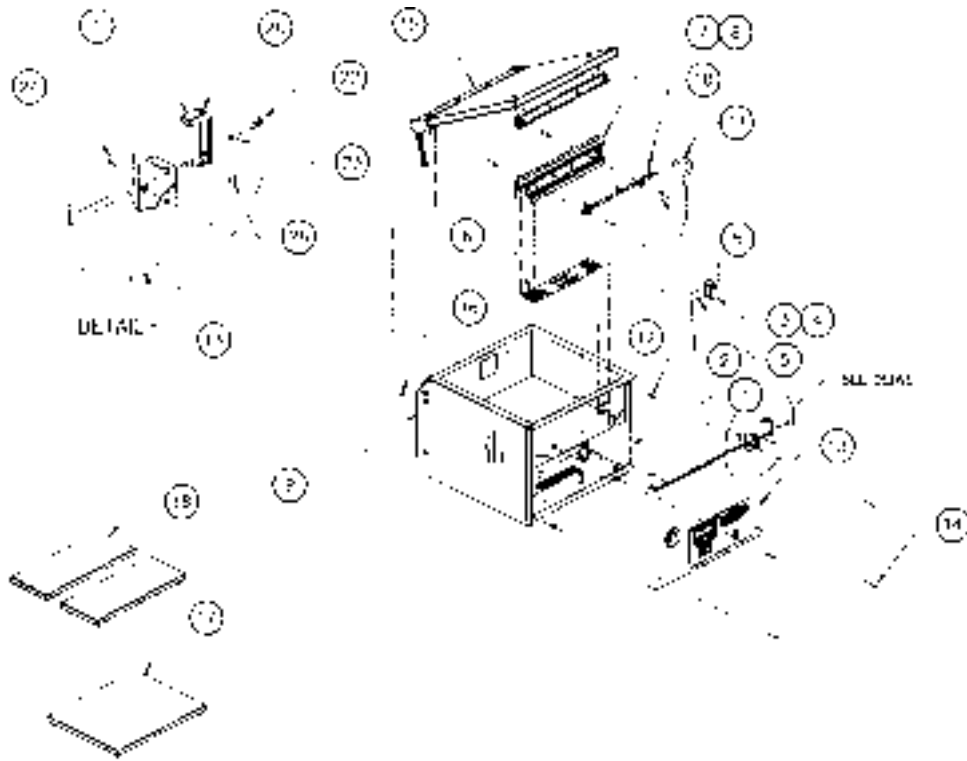

Model 350
Vacuum
Packaging Machine

Exploded Views
and Parts List

Front View



Item	Description	Part Number	Item	Description	Part Number
1	Housing	004-00229	14	Screw, 1/4-20	051-00264
2	Nut, 1/4-20 Nylon Lock	051-00581	15	Cover Assembly	005-00266
3	Left Guide Block	002-00029	16	Spacers	058-00030
4	Right Guide Block	002-00030	17	Filler Plate	005-00278
5	Washer, 1/4"	051-00740	18	Half Filler Plate	005-00364
6	Bellows Assembly	005-00045	20	Cover Hold Down	001-02073
8	Seal Bar Assembly	005-00558	21	Shrink Tube	030-00712
9	Rear Panel	004-00361	22	Bolt, 1/4-20 x 2/3"	051-00190
10	Gas Injection Bar	005B0042	23	Washer, 1/4"	051-00740
11	Gas Injection Tube	008-00464	24	Nut, 1/4-20 Nylon Lock	051-00581
12	Nut, 1/4-20	056-00020	26	Nylon Plug	057-00420
13	Front Panel Assembly	005-00450			

Rear View

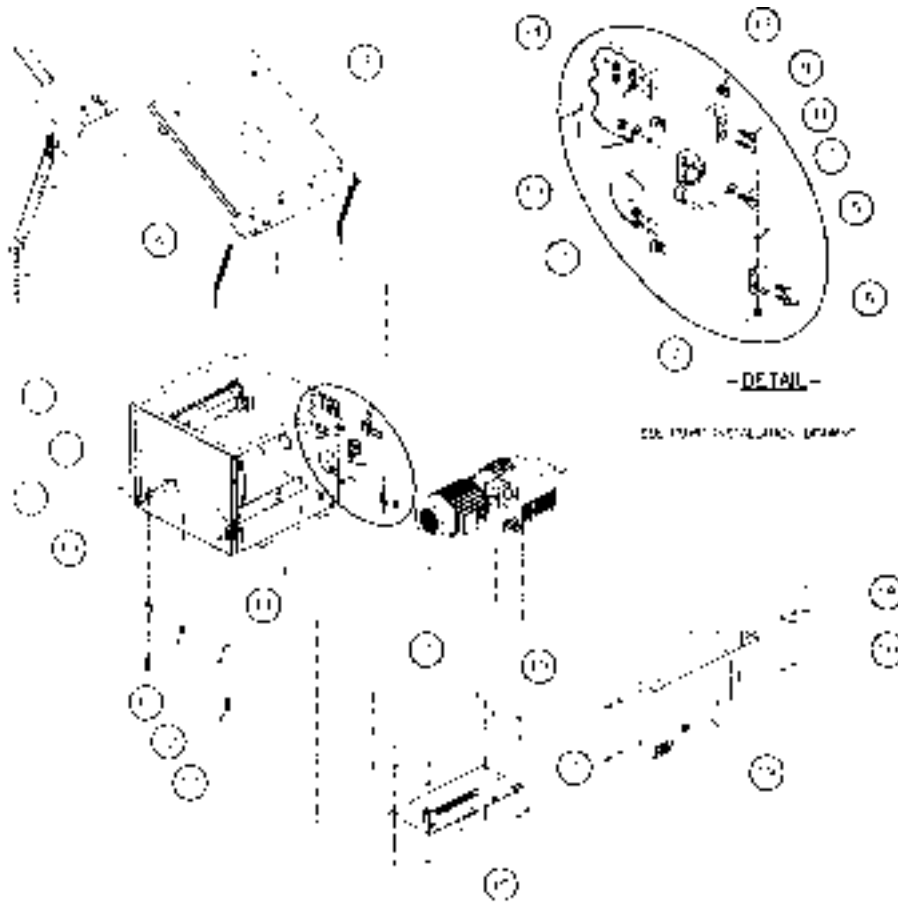

Item	Description	Part Number	Item	Description	Part Number
1	Housing	004-00229	11	Limit Switch Assembly	004-00261
2	Front Panel Assembly	005-00450	12	Feet	002-00022
3	Cover Assembly	005-00266	13	Bolt, 1/4-20 x 1-1/2"	051-00250
4	Spring Assembly	004A1224	14	Nut, 1/4-20 Nylon	051-00581
5	Bolt, 1/4-20 x 1/2"	001-01337	15	Electrical Support	004-00042
6	Nut, 1/4-20	051-00180	16	Bolt, 1/4-20 x 3/4"	051-00190
7	Washer, 1/4	051-00580	17	Nut, 1/4-20	056-00002
8	Hinge Block	002-00024	18	Screw, 1/4-20 x 1/2"	051-00185
9	Screw, 1/4-20 x 1-1/2"	051-00251	19	Rear Panel	004-00361
10	Washer, 1/4	051-00740			

Seal Bar Assembly

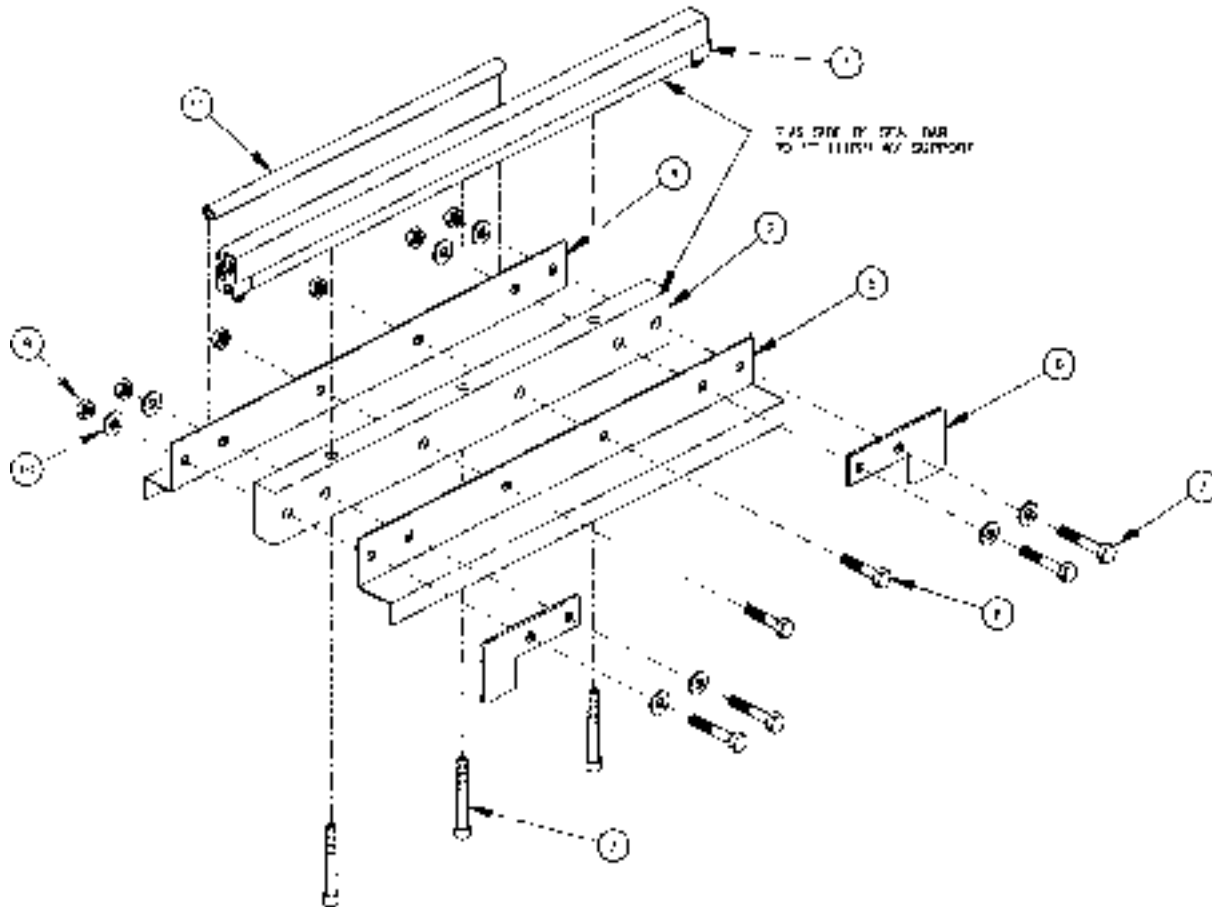

Item	Description	Part Number	Item	Description	Part Number
1	Seal Bar Pre-Assembly	005-00267	7	Bolt, 1/4-20 x 1-1/2"	051-00250
2	Support	002-00509	8	Bolt, 1/4-20 x 1-1/4"	051-00230
3	Bolt, 1/4-20 x 1-1/4"	051-00256	9	Nut, 1/4-20 Nylon	051-00581
4	Exterior Bellows Cover	001-01952	10	Washer, 1/4	051-00740
5	Interior Bellows Cover	001-01953	11	Wiring Duct	038-00230
6	Guide	001-00269			

Seal Bar Pre-Assembly

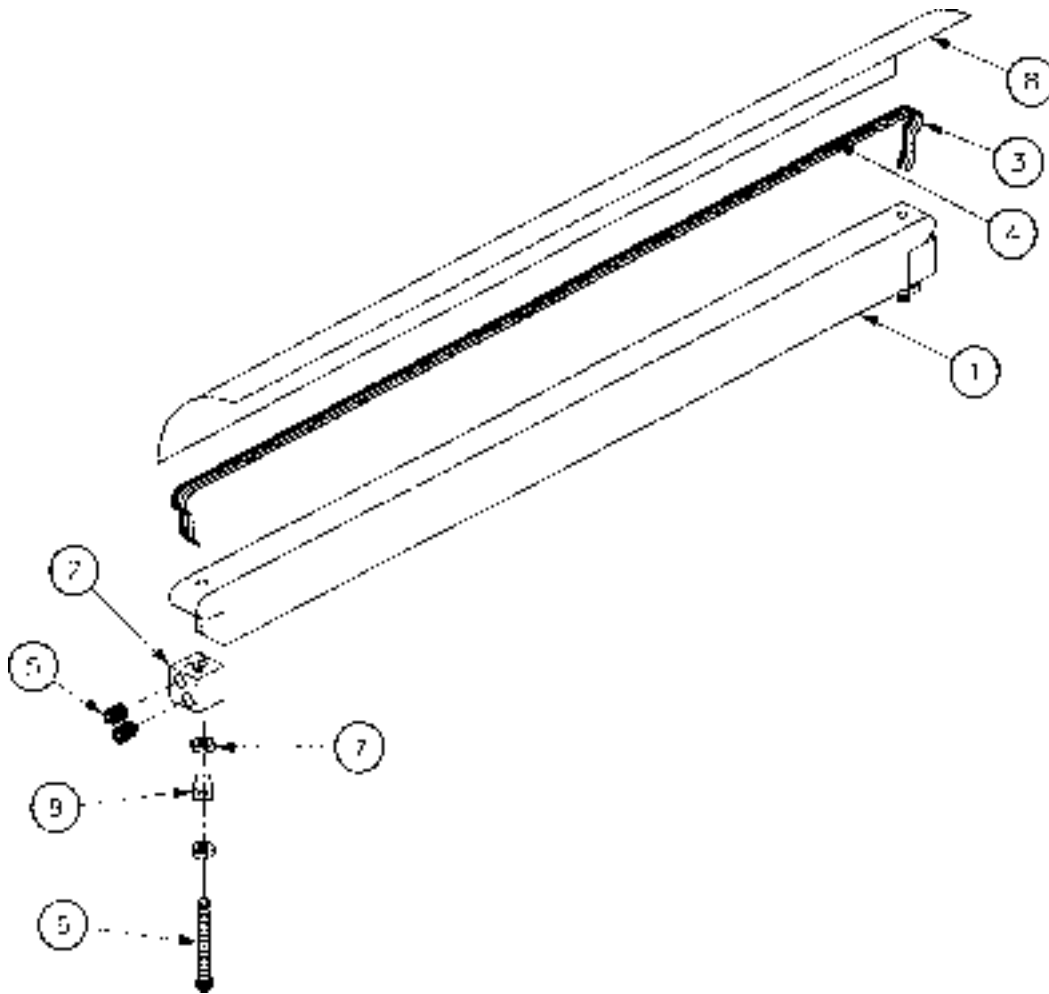

Item	Description	Part Number	Item	Description	Part Number
1	Seal Bar	002-00015	6	Screw, 8-32 x 1-1/2	052-00250
2	Connector	002-00031	7	Nut, 8-32	051-00550
3	Reflex Band	039-00230	8	Teflon Tape	176-00200
4	"T" Profile Wire	039-00270	9	Connector Adapter	027-00400
5	Set Screw, 1/4-20 x 5/16	052-0395			

Cover Assembly

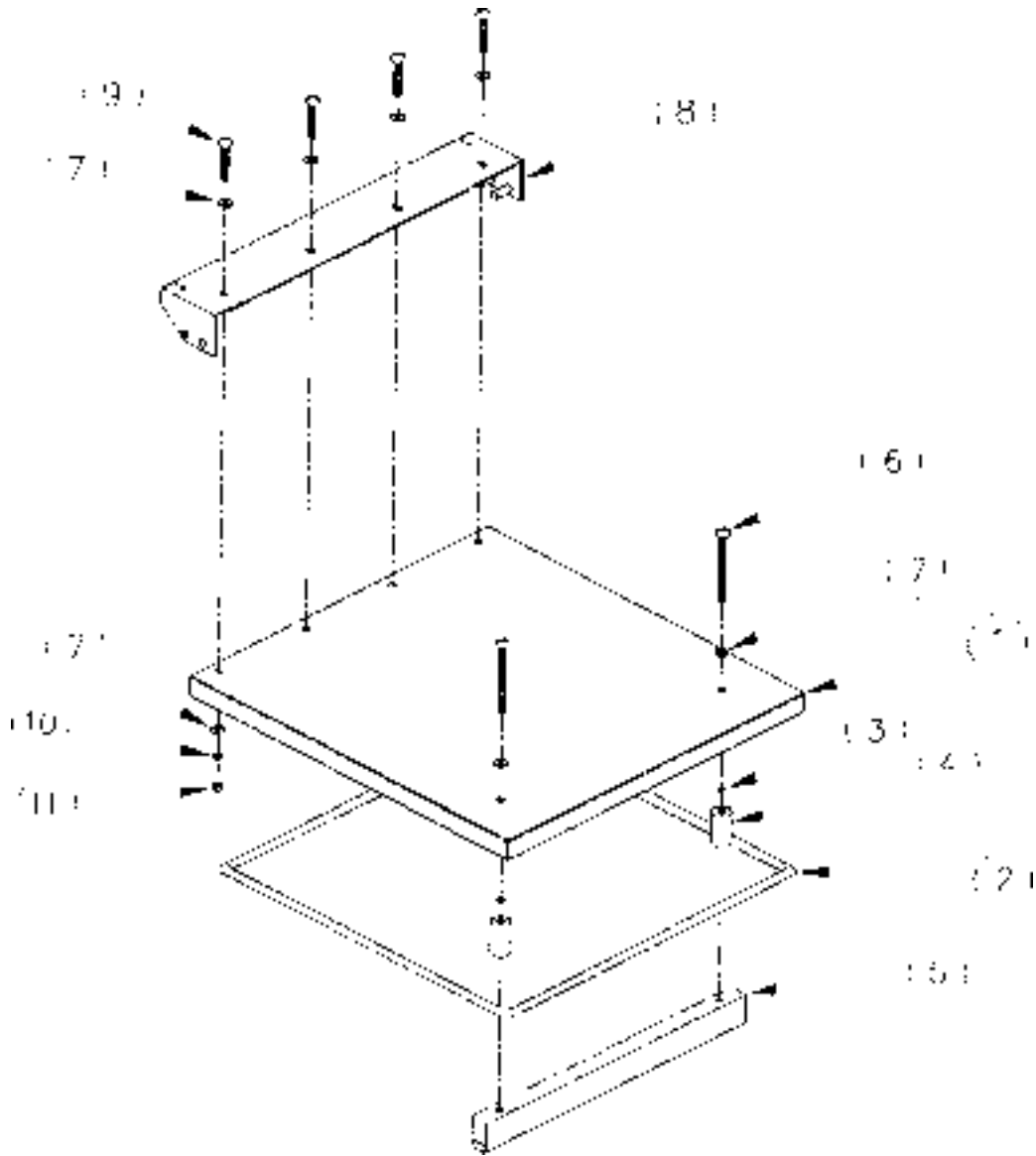

Item	Description	Part Number	Item	Description	Part Number
1	Cover	002-00392	7	Washer, 1/4	051-00740
2	Cover Gasket	179-00005	8	Cover Hinge Assy.	004-00021
3	"O" Ring	076-00010	9	Screw, 1/4-20 x 1-1/2	051-00249
4	Spacer	002-00026	10	Lock Washer, 1/4	051-00750
5	Upper Seal Bar Assy.	004A0173	11	Nut, 1/4-20	051-00580
6	Screw, 1/4-20 x 3"	051-00286	N/S	Upper Bar Rubber	008-00291

Electrical Schematic

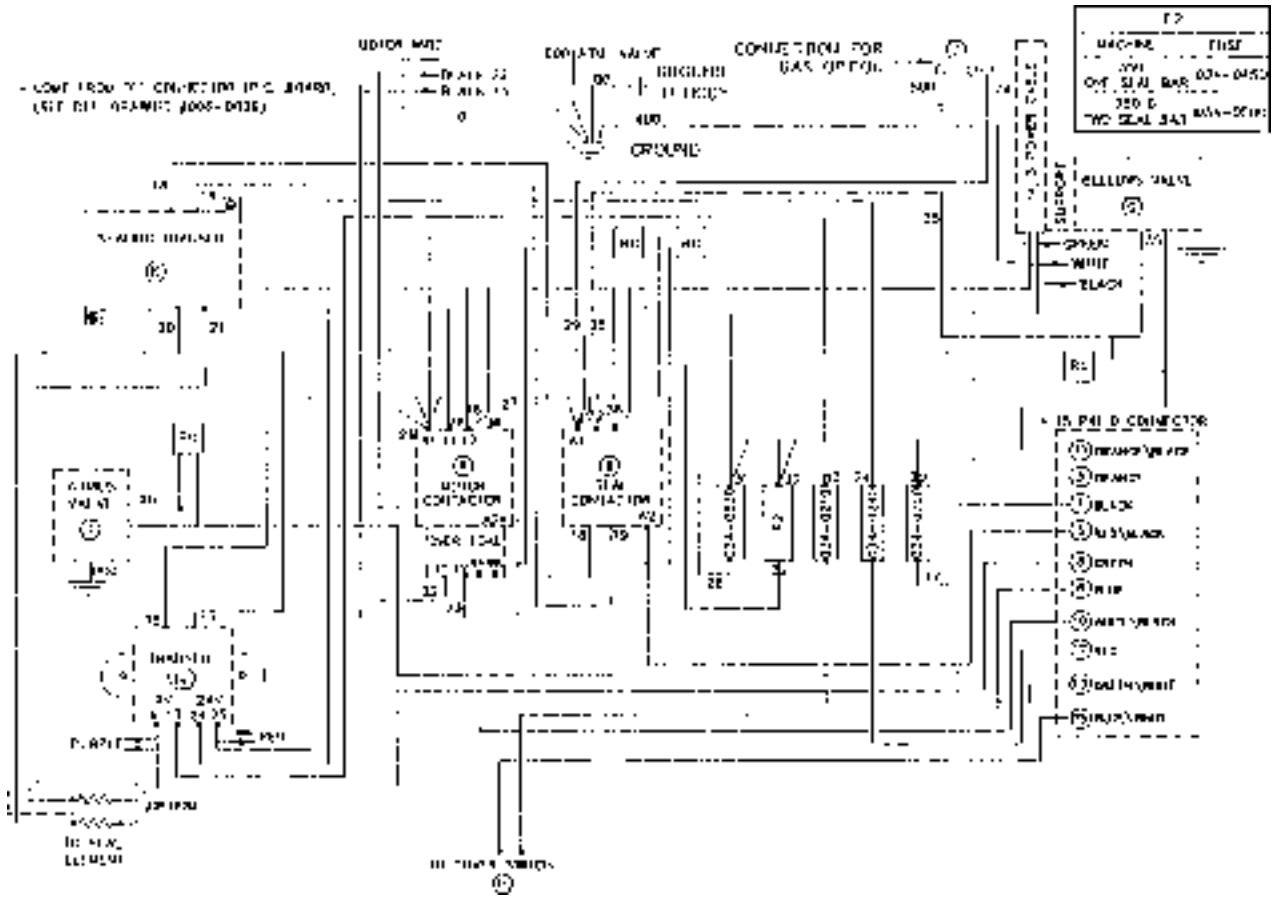

Item	Description	Part Number	Item	Description	Part Number
A	Motor Contactor	025-00030	F	Atmosphere Valve	106-00030
(A)	Contactor Overload	025-00190	G	Bellows Valve	106-00070
B	Sealing Contactor	025-00020	H	Cover Switch	026-00590
D	Gas Solenoid Valve	106-00010	K	Transformer, 350	029-00014
E	Vacuum Solenoid Valve	106-00030		Transformer, 350D	029-00040

“D” Connector Wiring

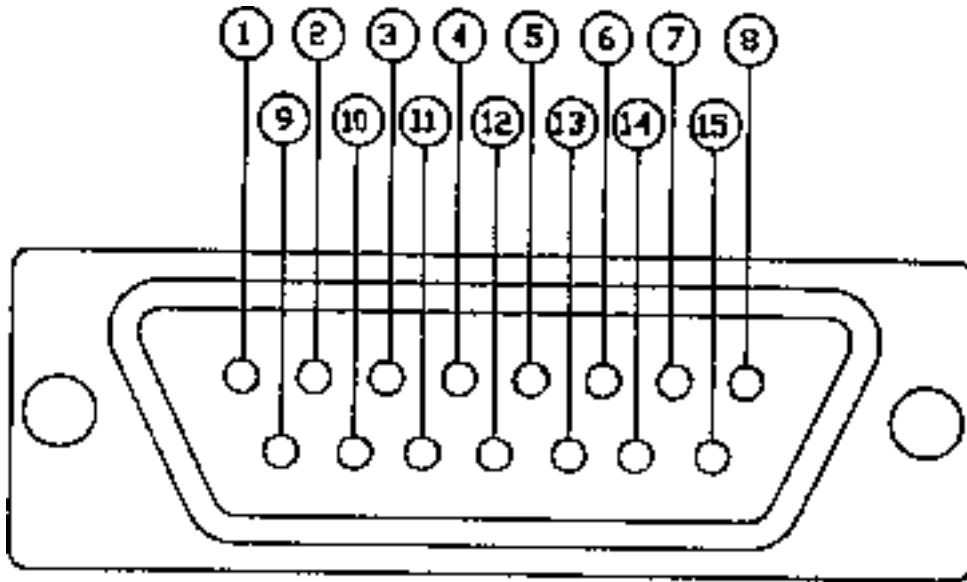

Wire Side View

- | | | |
|-----|---------------|---|
| 1. | Black: | Output to atmosphere valve |
| 2. | White: | Output to sealing contactor |
| 3. | Orange: | Output to gas valve |
| 4. | Red/White: | Contact of PC board relay, activates when machine is on |
| 5. | Red/Black: | Contact of PC board relay, activates when machine is on |
| 6. | Green: | Input 9 VAC |
| 7. | -----: | Jumped with 6 |
| 8. | Blue: | To cover switch |
| 9. | -----: | Not used |
| 10. | White/Black: | Output to vacuum valve |
| 11. | Orange/Black: | Output to sealing valve |
| 12. | Red: | Input 12 VAC |
| 13. | Green/White: | Input 9 VAC |
| 14. | -----: | Jumped with 13 |
| 15. | Blue/White: | To cover switch |

Pneumatic

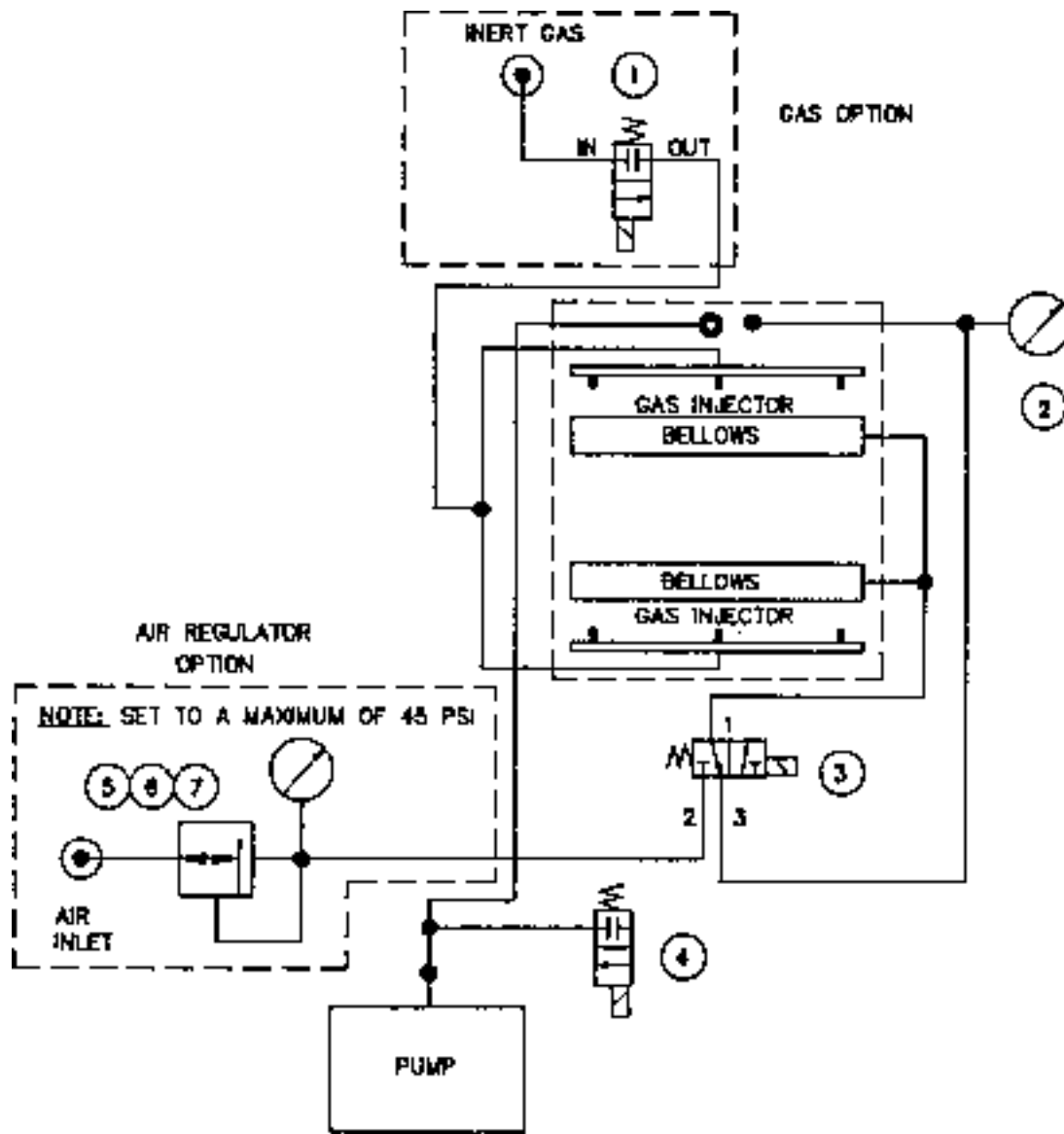

Item	Description	Part Number	Item	Description	Part Number
1	Gas Valve	106-00010	5	Pressure Regulator	114-00147
2	Vacuum Gauge	114-00260	6	Pressure Gauge	114-00245
3	Bellows Valve	106-00070	7	Support	114-00170
4	Atmosphere Valve	106-00020			

