

# VULCAN

## CATALOG OF REPLACEMENT PARTS

### GAS CONVECTION OVENS

#### MODELS

GCO4S	ML-52425
GCO4C	ML-52357
GCO4D	ML-52354

THIS CATALOG OBSOLETE  
AND REPLACES F-30918



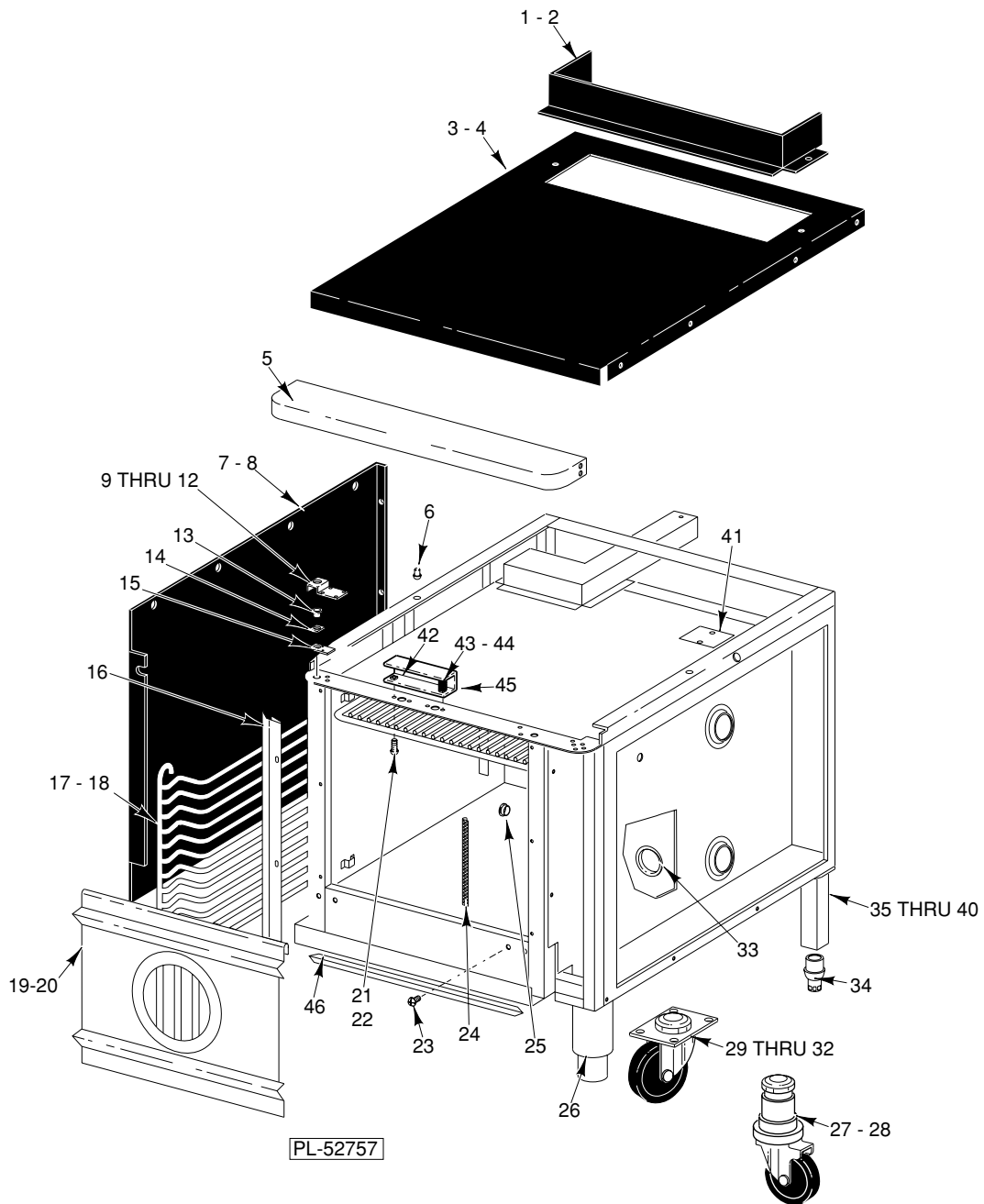

OVEN

## OVEN

ILLUS. PL-52757	PART NO.	NAME OF PART	AMT.
1	00-343516-00001	Shell - Chimney (PTD) .....	1
2	00-343516-00002	Shell - Chimney (SST) .....	1
3	00-343508-00001	Top - Rear (PTD) .....	1
4	00-343508-00002	Top - Rear (SST) .....	1
5	00-358450-00001	Top - Front (SST) .....	1
6	00-339337-00001	Stud - Locating .....	2
7	00-357760-00001	Panel - Outer (L.H.)(PTD) .....	1
8	00-357760-00002	Panel - Outer (L.H.)(SST) .....	1
9	00-353484-00001	Plate - Retainer .....	2
10	SC-053-41	Mach. Screw ¼-20 x ½ Truss Hd. SST .....	4
11	WL-019-22	Lockwasher ¼ Ext. ....	4
12	NS-046-52	Nut - ¼-20 Hex "Keeps" .....	4
13	00-347080-00002	Bearing - Door Shaft .....	2
14	00-353482-00001	Spacer .....	2
15	00-353483-00001	Plate - Upper Door Bearing .....	2
16	00-357508-00001	Seal - Door (23 Long) .....	2
17	00-342141-00001	Rack - Support (L.H.) .....	1
18	00-342141-00002	Rack - Support (R.H.) .....	1
19	00-357844-00001	Blower - Baffle (Porcelain) .....	1
20	00-355542-00001	Blower Baffle (SST) .....	1
21	SC-114-01	Mach. Screw 10-32 x ¾ Hex Washer Hd., Slotted .....	2
22	NS-046-88	Nut Assy. 10-32 HEX "KEPS" .....	2
23	SD-034-31	Self-Tapping Screw 6-20 x 5/16 Pan Phil. Hd., Type BT .....	14
24	00-342132-00002	Guard - Thermostat Bulb .....	1
25	00-342154-00002	Plug - Thermostat .....	1
26	00-342150-00005	Leg - Adjustable (8") .....	AR
27	00-410118-00017	Caster - (W/Brake)(6" High) .....	AR
28	00-410118-00016	Caster (6" High) .....	AR
29	00-343634-00001	Caster - (Swivel)(W/Brake)(7½") .....	AR
30	00-343634-00002	Caster - 7½" High (Rigid) .....	AR
31	SC-114-24	Cap Screw ¼-20 x ¾ Socket Hex Hd. ....	16
32	WS-029-49	Washer .....	16
33	FE-023-53	Bushing - Snap .....	2
34	00-412681-00001	Foot - Adjustable (PTD) .....	AR
35	00-358237-00001	Leg Assy. W/Foot (PTD) .....	AR
36	00-358237-00002	Leg Assy. W/Foot (SST) .....	AR
37	00-358237-00003	Leg Assy. W/Caster W/Brake (PTD) .....	AR
38	00-358237-00004	Leg Assy. W/Caster W/O Brake (PTD) .....	AR
39	00-358237-00005	Leg Assy. W/Caster W/Brake (SST) .....	AR
40	00-358237-00006	Leg Assy. W/Caster W/O Brake (SST) .....	AR
41	00-346358-00002	Hi-Limit Assy. ....	1
42	00-411794-00001	Catch - Door .....	2
43	00-417810-00003	Spring - Compression .....	2
44	SC-022-40	Mach. Screw ¼-20 x ¾ Phil. Flat Hd. ....	2
45	00-355344	Channel - Latch .....	1
46	00-357507-00001	Seal - Door (30½ Long) .....	2
	00-342552-00001	Stand Assy. (Open Stand)(32 <sup>9</sup> / <sub>16</sub> " ) .....	1
	00-354319-00001	Probe Assy. ....	1
	00-920883-00002	Probe - Thermocouple W/40" Leads .....	1
	00-355318-00004	Drip Pan .....	1

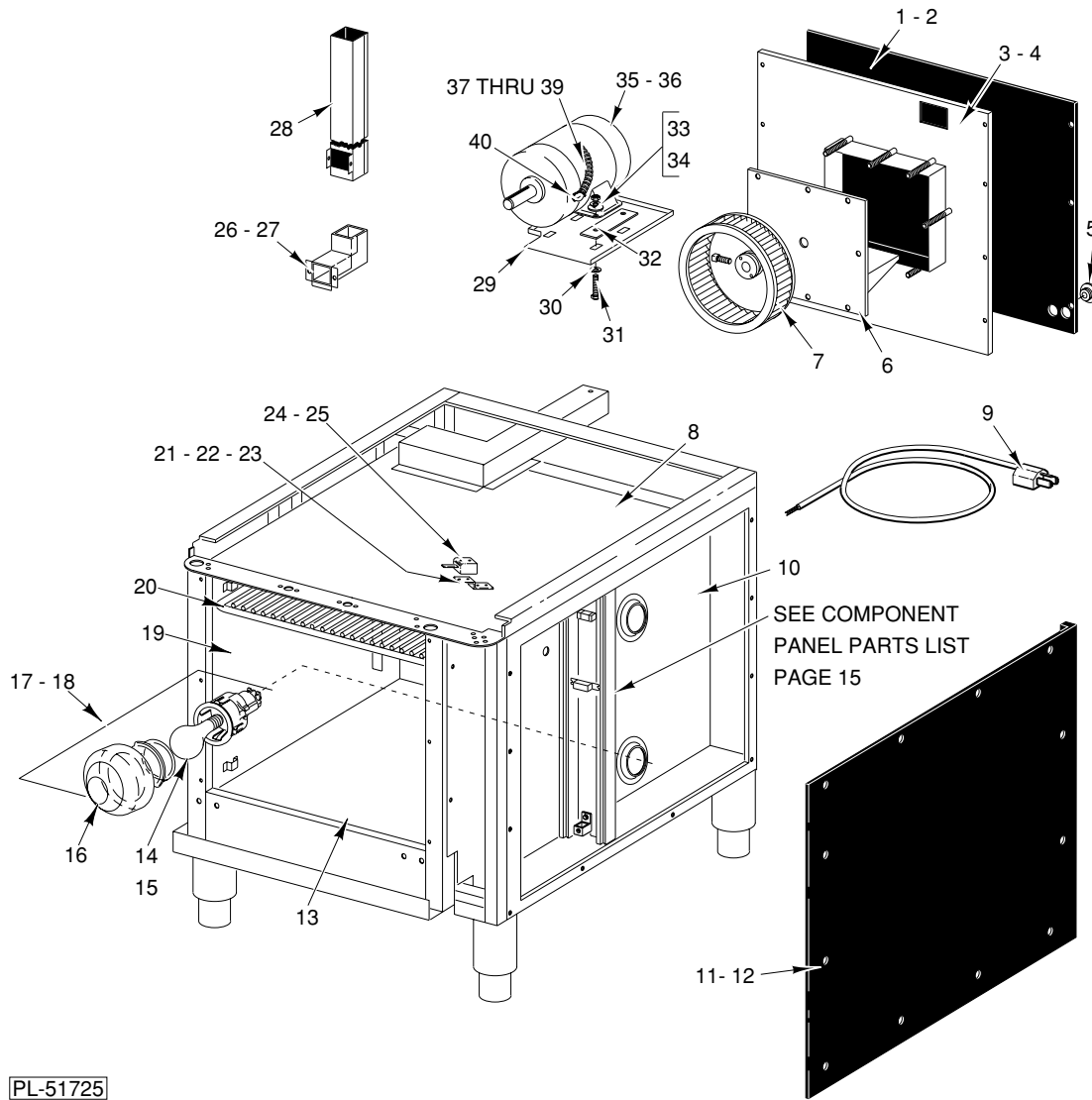

PL-51725

OVEN

OVEN

ILLUS. PL-51725	PART NO.	NAME OF PART	AMT.
1	00-358473-00001	Panel - Back (PTD) .....	1
2	00-358473-00002	Panel - Back (SST) .....	1
3	00-354960-00001	Back - Inner Panel .....	1
4	00-357436-00001	Back - Inner Panel (PTD) .....	1
5	00-355023-00001	Bushing - Snap .....	1
6	00-356633-00001	Motor Mount .....	1
7	00-358638-00001	Wheel - Blower (Incls. 5/16"-24 UNF SST Sq. Hd. Bolt) .....	1
8	00-357575-00001	Panel - Top .....	1
9	00-405016-00001	Cord - Electric Supply .....	1
10	00-357576-00001	Panel - Side (RH) .....	1
11	00-358480-00001	Panel - Outer (RH)(PTD) .....	1
12	00-358480-00002	Panel - Outer (RH)(SST) .....	1
13	00-357440-00001	Panel - Bottom .....	1
14	00-342766-00001	Light Bulb - Oven (40 Watts) (120 V.) .....	2
15	00-342766-00002	Light Bulb-Oven (240V.,40 Watts) .....	2
16	00-357036-00003	Lens - Oven Lamp .....	2
17	00-357036-00001	Oven Lamp Assy. (40 Watt 120 - 130 V.) .....	2
18	00-357036-00002	Oven Lamp Assy. (40 Watts 250 V.) .....	2
19	00-357577-00001	Panel - Side (LH) .....	1
20	00-342142-00001	Rack Assy. (28" x 20.56") .....	AR
21	00-343509-00001	Bracket - Door Switch .....	1
22	00-343612-00001	Housing - Receptacle .....	1
23	SD-034-47	Self-Tapping Screw 6-32 x 1 Hex Washer Hd., Type T .....	2
24	00-342147-00001	Switch - Door .....	1
25	SD-034-62	Self-Tapping Screw 10-32 x 1/2 Hex Washer Hd., Type T .....	2
26	00-354975-00001	Flue Deflector Assy. ....	1
27	SD-034-45	Self-Tapping Screw 6-32 x 3/8 Rd. Hd., Type T .....	2
28	00-355108-00001	Vent Assy. - Common (Stacked Units) .....	1
29	00-345523-00001	Baffle - Motor .....	1
30	WS-029-46	Washer .....	4
31	SC-113-65	Cap Screw 5/16"-18 x 1 1/4 Hex Hd. ....	4
32	00-358723-00001	Spacer - Steel .....	2
33	WS-029-46	Washer .....	4
34	NS-046-86	Nut Assy. 5/16"-18 "KEPS" Hex .....	4
35	00-358516-00001	Motor 1/8 Hp (2 Speed)(115, 50/60 Hz., 1 Ph.) .....	1
36	00-358516-00002	Motor 1/8 Hp. (2 Speed)(208-230, 50/60 Hz., 1 Ph.) .....	1
37	FE-006-05	Lock Nut 1/2 .....	1
38	00-342151-00001	Conduit .....	1
39	00-342285-00001	Bushing - Plastic .....	2
40	FE-002-52	Connector - Conduit 3/8 TS 90 Deg. ....	1
	00-358279	Flue - Common (Stacked Units)(Packaged)(Incls. item 28) .....	1

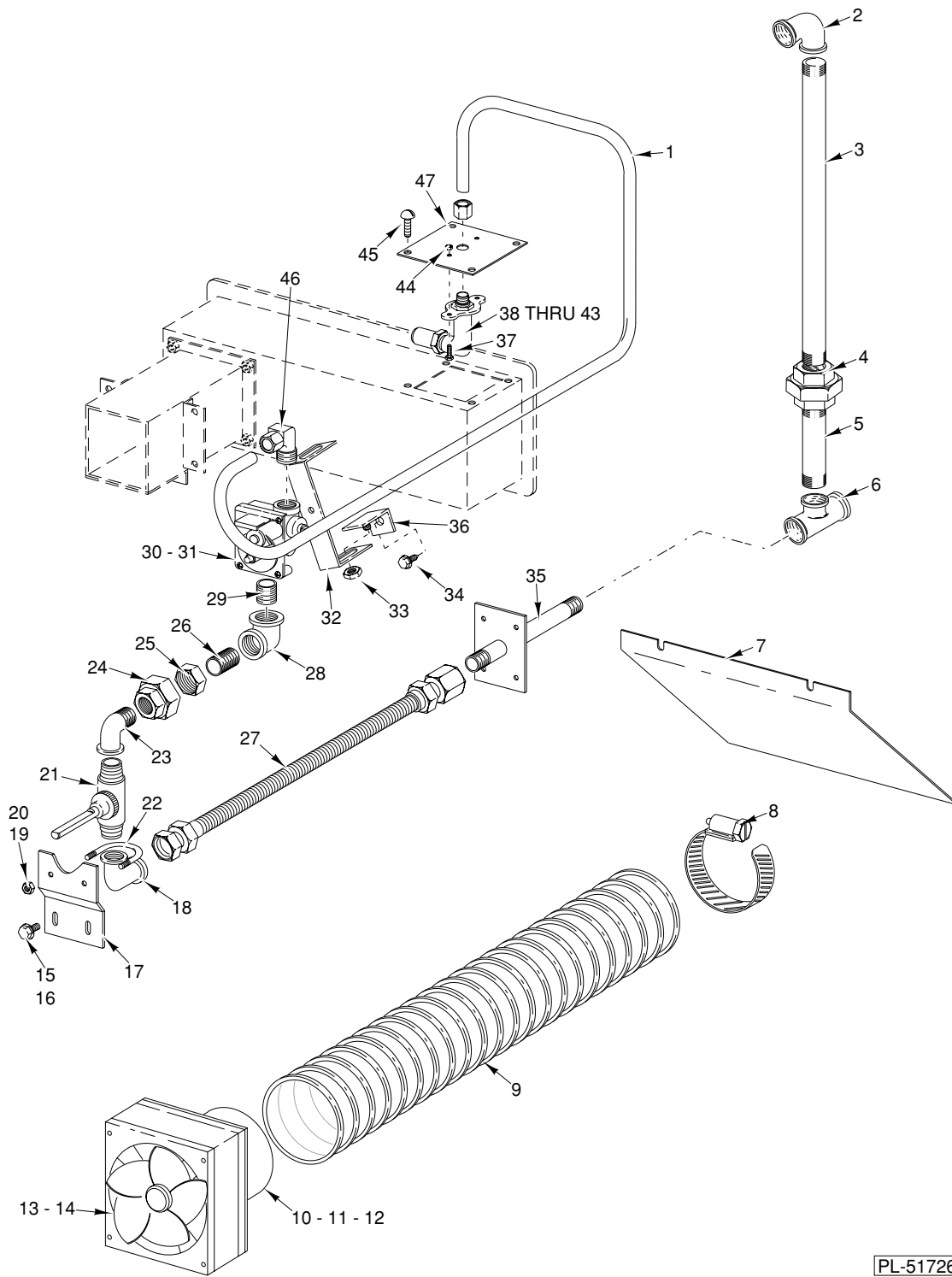

**GAS PIPING**

**GAS PIPING**

ILLUS. PL-51726	PART NO.	NAME OF PART	AMT.
*1	00-356588-00001	Tube - Gas Inlet .....	1
*2	FP-077-68	Elbow 1/2 x 90 Deg. ....	1
*3	FP-075-27	Nipple 1/2 x 21 T.B.E. ....	1
*4	FP-022-11	Union - Pipe .....	1
*5	FP-058-51	Nipple 1/2 x 5 TBE .....	1
*6	FP-019-25	Tee 1/2 x 1/2 x 1/2 .....	1
7	00-358490-00001	Shield - Exhaust Tube (Mount to Back Panel) .....	1
8	00-521462	Clamp - Hose .....	2
9	00-355726-00002	Tube - Exhaust (28") .....	1
10	00-355724-00001	Tube - Bracket Assy. ....	1
11	SC-021-10	Mach. Screw 6-32 x 1/2 Rd. Hd .....	6
12	NS-046-89	Nut Assy. 6-32 Hex "KEPS" .....	6
13	00-415207-00001	Fan - Cooling (120 V.) .....	1
14	00-415207-00002	Fan Cooling (230 V.) .....	1
15	SC-041-01	Cap Screw 1/4-20 x 3/4 Hex Hd .....	2
16	WL-006-17	Lockwasher 1/4 Medium .....	2
17	00-356735-00001	Support - Valve .....	1
18	FP-087-19	Elbow - Reducing 1/2 x 3/8 x 90 Deg. Brass .....	1
19	NS-015-01	Full Nut 1/4-20 Hex SST .....	2
20	WL-006-17	Lockwasher 1/4 Medium .....	2
21	00-407789-00003	Valve - Service .....	1
22	00-521820	"U" Bolt 1/4 -20 .....	1
23	FP-078-75	Street Elbow 3/8 x 90 Deg. ....	1
24	00-348049-00201	Union (Tail & Nut) .....	1
25	00-348049-00101	Union (Head) .....	1
26	FP-035-52	Nipple 3/8 x 2 TBE .....	1
27	00-356737-00001	Tube - Flex (24"Lg.) .....	1
28	FP-013-11	Elbow 3/8 x 90 Deg. ....	1
29	FP-035-46	Pipe 3/8 x 1 Lg. (T.B.E.) .....	1
30	00-354344-00004	Valve - Gas Control (Natural) .....	1
31	00-354344-00005	Valve - Gas Control (Propane) .....	1
32	00-356637-00001	Support - Solenoid .....	1
33	NS-046-52	Nut - 1/4-20 Hex "Keps" .....	2
34	SD-036-51	Self-Tapping Screw 8-32 x 3/8 Hex Washer Hd., Type T .....	2
35	00-356738-00001	Pipe - Weldment Gas Inlet .....	1
36	00-356638-00001	Bracket - Solenoid .....	2
37	SC-119-31	Mach. Screw 10-24 x 3/8 Hex Hd SST .....	2
38	00-356585-00001	Fitting - Orifice (29 Drill)(Nat.)(Sea Level to 2499 Ft) .....	1
39	00-356585-00002	Fitting - Orifice (30 Drill)(Nat)(2500 to 6499 Ft) .....	1
40	00-356585-00003	Fitting - Orifice (31 Drill)(Nat)(6500 to 7499 Ft) .....	1
41	00-356585-00004	Fitting - Orifice (48 Drill)(PRO)(Sea Level to 2499 Ft) .....	1
42	00-356585-00005	Fitting - Orifice (49 Drill)(PRO)(2500 to 6499 Ft) .....	1
43	00-356585-00006	Fitting - Orifice (50 Drill)(PRO)(6500 to 7499 Ft) .....	1
44	NS-044-09	Nut Assy. 10-24 Hex Keps .....	2
45	SD-034-15	Self-Tapping Screw 8-18 x 3/8 Rd. Hd., Type AB .....	4
46	FP-085-68	Fitting-Tube 7/16 .....	1
47	00-356584-00001	Plate - Orifice .....	1

\*Use on Stacked Units.

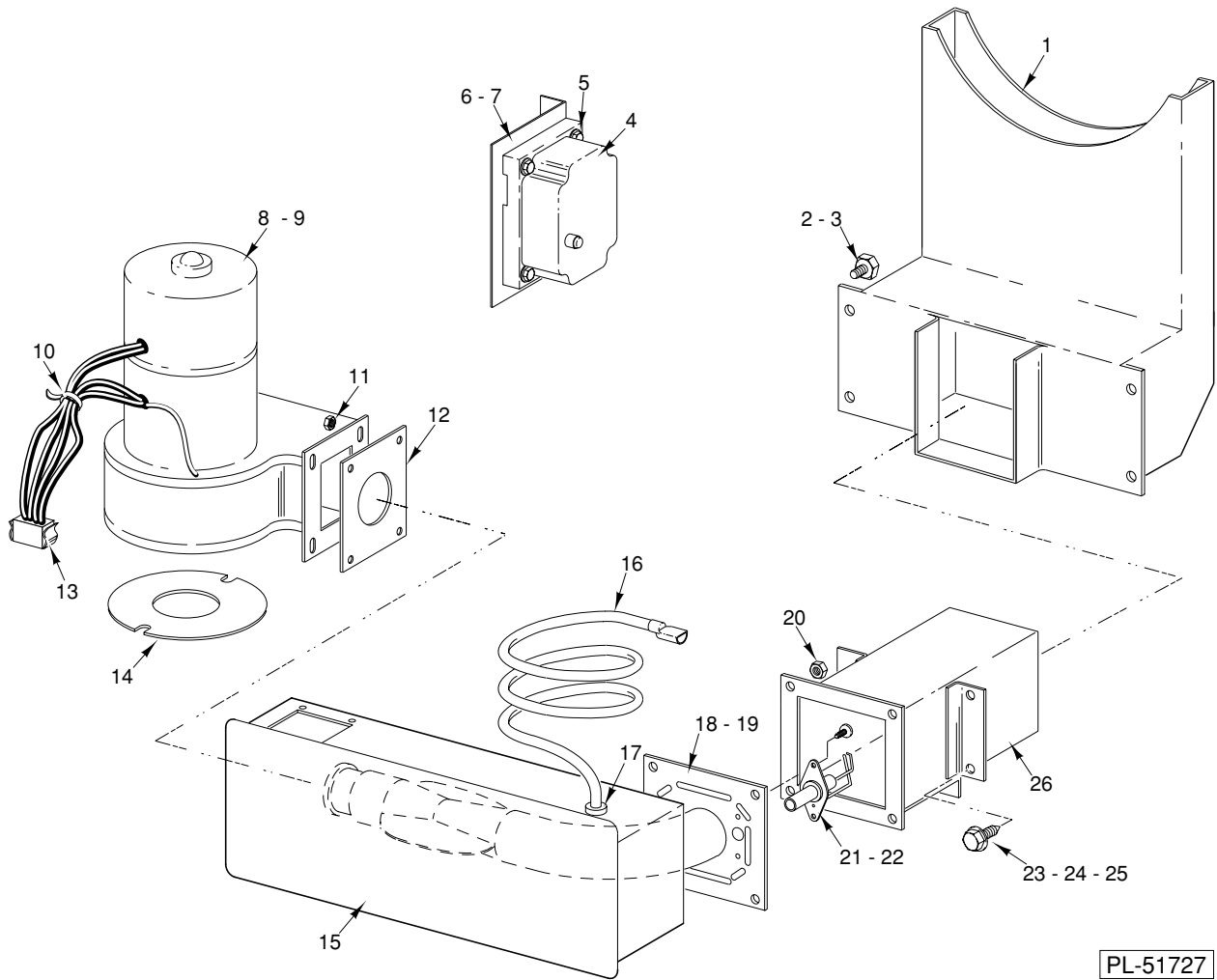

PL-51727

**COMBUSTION CHAMBER**



**COMBUSTION CHAMBER**

ILLUS. PL-51727	PART NO.	NAME OF PART	AMT.
1	00-356590-00001	Heat Exchanger Assy. ....	1
2	SD-037-80	Self-Tapping Screw 10-24 x ½ Hex Washer Hd., Type TT .....	4
3	WL-006-06	Lockwasher 10 Light .....	4
4	00-356589-00002	Controller - Spark Ignitor .....	1
5	SD-034-52	Self-Tapping Screw 8-32 x 1 Hex Washer Hd., Type T .....	4
6	SD-034-21	Self-Tapping Screw 10-16 x ½ Sl. Hex Washer Hd., Type AB .....	2
7	00-356594-00001	Bracket - Ignition Module .....	1
8	00-354984-00001	Motor Blower Assy. (120 V.) .....	1
9	00-354984-00003	Motor Blower Assy. (230 V.) .....	1
10	00-251199	Tie - Cable (4" Long) .....	3
11	NS-046-52	Nut - ¼ -20 Hex "Keps" .....	4
12	00-355017-00001	Gasket - Blower Motor .....	1
13	00-345519-00002	Plug (Natural)(12 Circuits) .....	1
14	00-355047-00001	Restrictor - Blower Plate (1¼ Dia. Hole) .....	1
15	00-356576-00001	Burner Box Assy. ....	1
16	00-356595-00001	Cable - High Voltage .....	1
17	FE-016-23	Bushing .....	1
18	00-356571-00002	Burner Assy. ....	1
19	00-356586-00001	Insulation - Burner .....	1
20	NS-046-52	Nut - ¼ -20 Hex "Keps" .....	4
21	00-356587-00001	Electrode - Ignition .....	1
22	SD-036-17	Self-Tapping Screw 8-18 x ⅜ Phil. Pan Hd., Type AB .....	2
23	SC-113-80	Cap Screw ¼ -20 x ½ Hex Hd. ....	4
24	WL-006-17	Lockwasher ¼ Medium .....	4
25	NS-046-52	Nut - ¼ -20 Hex "Keps" .....	4
26	00-356579-00001	Box - Combustion .....	1

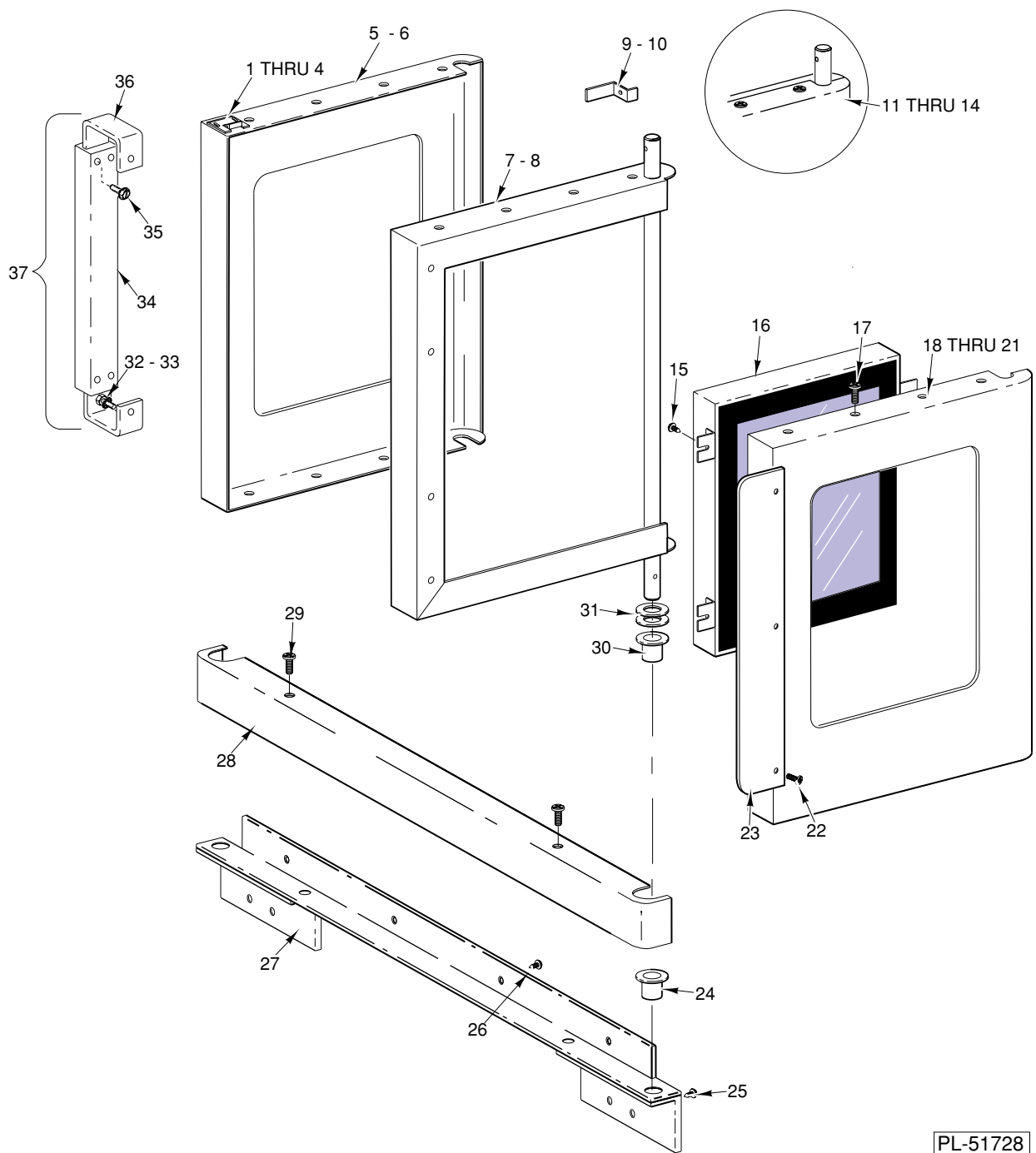

PL-51728

DOOR

## DOOR

ILLUS. PL-51728	PART NO.	NAME OF PART	AMT.
1	00-357877-00001	Shim - Door Strike .....	2
2	00-358542-00001	Strike - Door .....	1
3	00-350543-00006	Mach. Screw 10-32 x 1/2 Phil. Pan Hd. ....	2
4	WL-019-35	Lockwasher 10 Int. ....	2
5	00-358531-00001	Shell - Outer Door (W/Window) .....	1
6	00-358531-00002	Shell - Outer Door (W/O Window) .....	1
7	00-357840-00002	Frame Assy. - Door (R.H.) .....	1
8	00-357841-00002	Frame Assy. - Door (L.H.) .....	1
9	00-356253-00001	Lever - Door Switch .....	1
10	SD-034-52	Self-Tapping Screw 8-32 x 1 Hex Washer Hd., Type T .....	1
11	00-358529-00001	Door Assy. (LH)(W/Window)(Incls. items 1 thru 5,8,15,16,17,19,22 & 23) .....	1
12	00-358529-00002	Door Assy. (LH)(W/O Window)(Incls. items 1 thru 4,6,8,17,22 & 23) .....	1
13	00-358530-00001	Door Assy. (RH)(W/Window)(Incls. items 1 thru 5,7,15 thru 18 & 22) .....	1
14	00-358530-00002	Door Assy. (RH)(W/O Window)(Incls. items 1 thru 4,6,7,17 & 20) .....	1
15	SD-034-62	Self-Tapping Screw 10-32 x 1/2 Hex Washer Hd., Type T .....	4
16	00-358534-00001	Window Assy. ....	1
17	00-350543-00006	Mach. Screw 10-32 x 1/2 Phil. Pan Hd. ....	7
18	00-358532-00002	Shell - Inner Door (W/Window)(RH) .....	1
19	00-358532-00001	Shell - Inner Door (W/Window)(LH) .....	1
20	00-358533-00004	Shell - Inner Door (Solid)(RH) .....	1
21	00-358533-00003	Shell - Inner Door (Solid)(LH) .....	1
22	00-350543-00006	Mach. Screw 10-32 x 1/2 Phil. Pan Hd. ....	3
23	00-357837-00001	Seal - Door End .....	1
24	00-347080-00002	Bearing - Door Shaft .....	1
25	SC-113-90	Mach. Screw 1/4 -20 x 3/4 Hex Hd. ....	2
26	SC-022-40	Mach. Screw 1/4 -20 x 3/4 Phil. Flat Hd. ....	4
27	00-357873-00001	Sill - Bottom Weldment .....	1
28	00-343515-00001	Front Cover - Door Sill (SST) .....	1
29	SD-034-59	Self-Tapping Screw 10-32 x 3/8 Phil. Pan Hd., Type T .....	2
30	00-347080-00002	Bearing - Door Shaft .....	1
31	00-343143-00001	Washer .....	4
32	SC-041-01	Cap Screw 1/4 -20 x 3/4 Hex Hd. ....	2
33	WL-019-37	Lockwasher 1/4 Int. ....	2
34	00-413029-00003	Handle .....	1
35	SD-037-02	Self-Tapping Screw 10-16 x 1/2 Hex Washer Hd., Type AB .....	4
36	00-358728-00001	End - Handle .....	2
37	00-358727-00001	Door Handle Assy. (Incls. items 34,35 & 36) .....	1

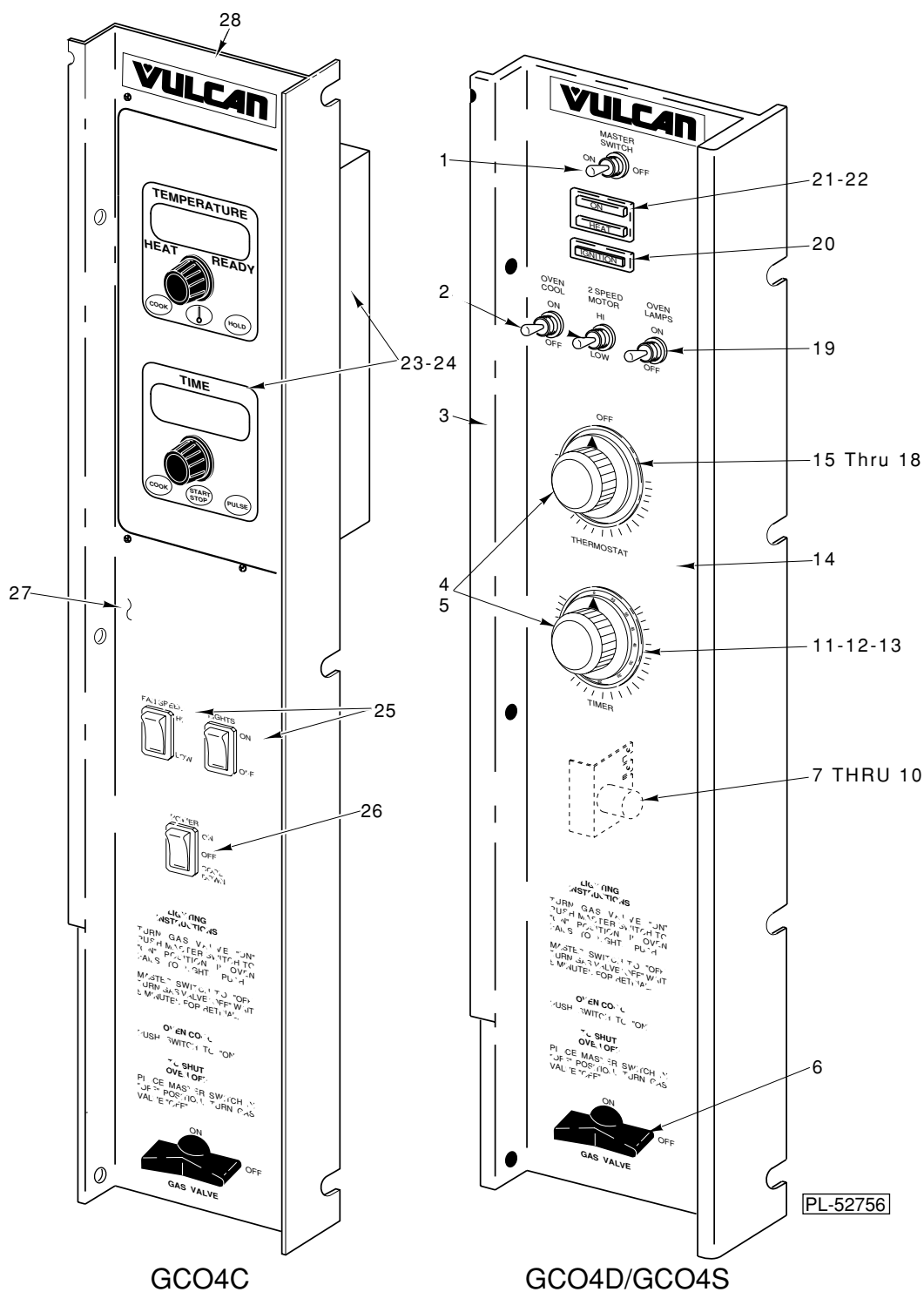

**CONTROL PANEL**

**CONTROL PANEL**

ILLUS. PL-52756	PART NO.	NAME OF PART	AMT.
1	00-340324-00006	Switch (D.P.S.T.) .....	1
2	00-340324-00009	Switch (D.P.D.T.) .....	2
3	00-358625-00001	Panel - Control .....	1
4	00-411242-00001	Knob (GCO4D/GCO4S) .....	2
5	SC-109-10	Mach. Screw 6-32 x 3/8 Pan Hd. ....	2
6	00-402957-00003	Handle - Gas Cock (Black) .....	1
7	00-411499-00003	Buzzer (230 V.) (GCO4D/GCO4S) .....	1
8	00-411499-00004	Buzzer (115 V.) (GCO4D/GCO4S) .....	1
9	SD-034-49	Self-Tapping Screw 8-32 x 1/2 Hex Washer Hd., Type T .....	1
10	WL-014-10	Lockwasher 1/4 Ext. "Shakeproof" .....	1
11	00-411690-00001	Timer (110-120 V.)(1 Hr.)(GCO4D/GCO4S) .....	1
12	00-411690-00002	Timer (200-240 V.)(1 Hr.)(GCO4D/GCO4S) .....	1
13	00-411690-00005	Timer (240/50)(1 Hr.) (GCO4D/GCO4S) .....	1
14	00-358447-00001	Overlay - Panel .....	1
15	00-411506-00003	Thermostat (Convection Oven) (GCO4S) .....	1
16	00-358539-00002	Plate - Dial Temperature (GCO4D/GCO4S) .....	2
17	00-358538-00001	Plate - Dial Timer (GCO4D) .....	1
18	00-358539-00001	Plate - Dial Temperature (GCO4D) .....	1
19	00-340324-00012	Switch (S.P.S.T.) .....	1
20	00-354575-00004	Light - Indicator (No Ignition) .....	1
21	00-354575-00002	Light - Indicator (On/Heat)(110-120V.) .....	1
22	00-354575-00001	Light Indicator (On/Heat) (200-240V) .....	1
23	00-355903-00004	Controller W/Cook, Hold & Pulse .....	1
24	NS-011-07	Mach. Nut 6-32 Hex .....	4
25	00-358628-00002	Switch - Rocker (2 Position) .....	2
26	00-358628-00001	Switch - Rocker (3 Position) .....	1
27	00-355891-00001	Overlay - Panel .....	1
28	00-355886-00001	Panel - Control .....	1

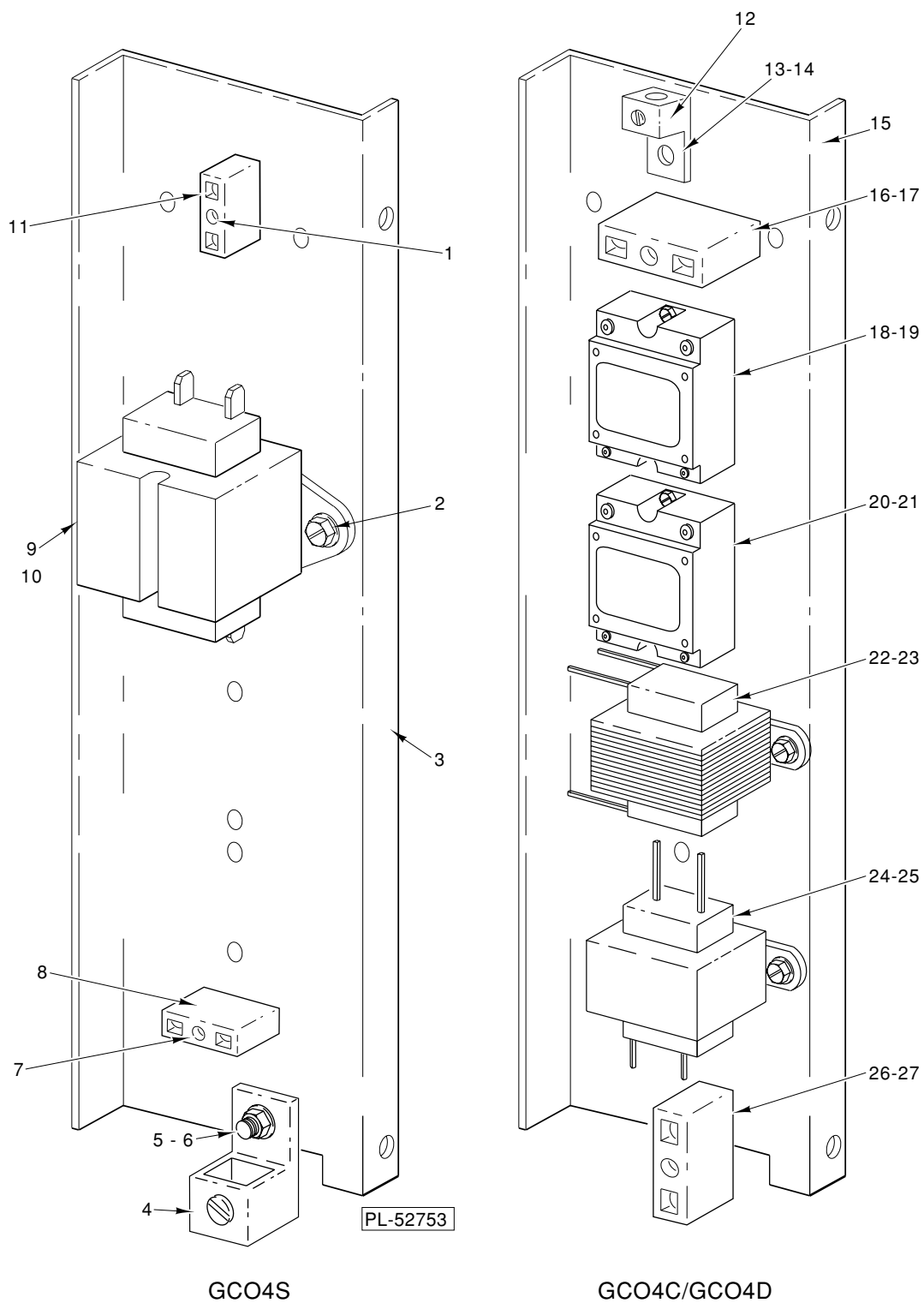

GCO4S

GCO4C/GCO4D

**ELECTRICAL COMPONENT PANEL**

**ELECTRICAL COMPONENT PANEL**

ILLUS. PL-52753	PART NO.	NAME OF PART	AMT.
1	SD-034-52	Self-Tapping Screw 8-32 x 1 Hex Washer Hd., Type T .....	1
2	SD-034-49	Self-Tapping Screw 8-32 x 1/2 Hex Washer Hd., Type T .....	2
3	00-358705-00001	Panel - Component .....	1
4	00-417856-00001	Lug - Grounding (With Set Screw) .....	1
5	SC-114-03	Mach. Screw 10-32 x 1/2 Hex Washer Hd. ....	1
6	NS-046-88	Nut Assy. 10-32 HEX "KEPS" .....	1
7	SD-034-52	Self-Tapping Screw 8-32 x 1 Hex Washer Hd., Type T .....	1
8	00-417934-000G1	Porcelain - Block Assy. ....	1
9	00-421758-000G1	Transformer (120 V) .....	1
10	00-421758-000G2	Transformer (208-240 V) .....	1
11	00-417934-000G1	Porcelain - Block Assy. ....	1
12	00-417856-00001	Lug - Grounding (With Set Screw) .....	1
13	SC-114-03	Mach. Screw 10-32 x 1/2 Hex Washer Hd. ....	1
14	NS-046-88	Nut Assy. 10-32 HEX "KEPS" .....	1
15	00-358705-00001	Panel - Component .....	1
16	00-417934-000G1	Porcelain - Block Assy. ....	1
17	SD-034-52	Self-Tapping Screw 8-32 x 1 Hex Washer Hd., Type T .....	1
18	00-821875-00002	Relay - Solid State (50Amp) .....	1
19	SD-034-49	Self-Tapping Screw 8-32 x 1/2 Hex Washer Hd., Type T .....	2
20	00-821875-00003	Relay-Solid State (10 Amp) .....	1
21	SD-034-49	Self-Tapping Screw 8-32 x 1/2 Hex Washer Hd., Type T .....	2
22	00-358629-000G1	Transformer .....	1
23	SD-034-49	Self-Tapping Screw 8-32 x 1/2 Hex Washer Hd., Type T .....	2
24	00-423866	Diagram - Wiring .....	1
25	SD-034-49	Self-Tapping Screw 8-32 x 1/2 Hex Washer Hd., Type T .....	2
26	00-417934-000G1	Porcelain - Block Assy. ....	1
27	SD-034-52	Self-Tapping Screw 8-32 x 1 Hex Washer Hd., Type T .....	1

