

VULCAN

*CATALOG OF
REPLACEMENT PARTS*

TILTING SKILLET

MODEL

VETRS35 ML-114826



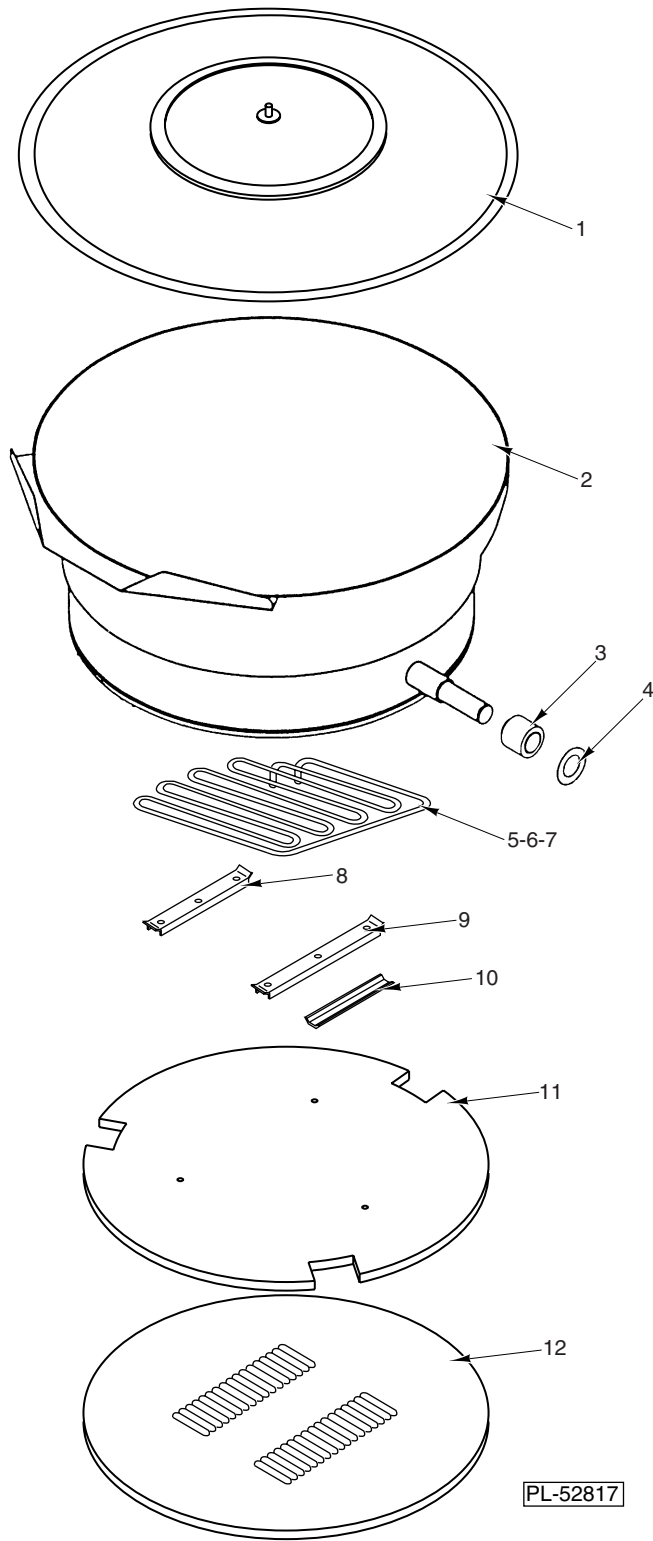

TILTING SKILLET ASSEMBLY

TILTING SKILLET ASSEMBLY

ILLUS. PL-52817	PART NO.	NAME OF PART	AMT.
1	00-851350	Cover - Pan	1
2	00-851349	Pan Assy.	1
3	00-851351	Spacer - Trunion	2
4	00-850613	Washer	2
5	00-851362	Element Assy. (208V, 6 KW)(Select as Required)	3
6	00-851363	Element Assy. (240V, 6 KW)(Select as Required)	3
7	00-851528	Element Assy. (277V, 6 KW)(Select as Required)	3
8	00-851364	Clamp - Element	3
9	00-851365	Clamp - Element	3
10	00-851367	Clamp - Hi - Limit Bulb	1
11	00-851368	Insulation Pan Assy.	1
12	00-851369	Cover - Bottom	1

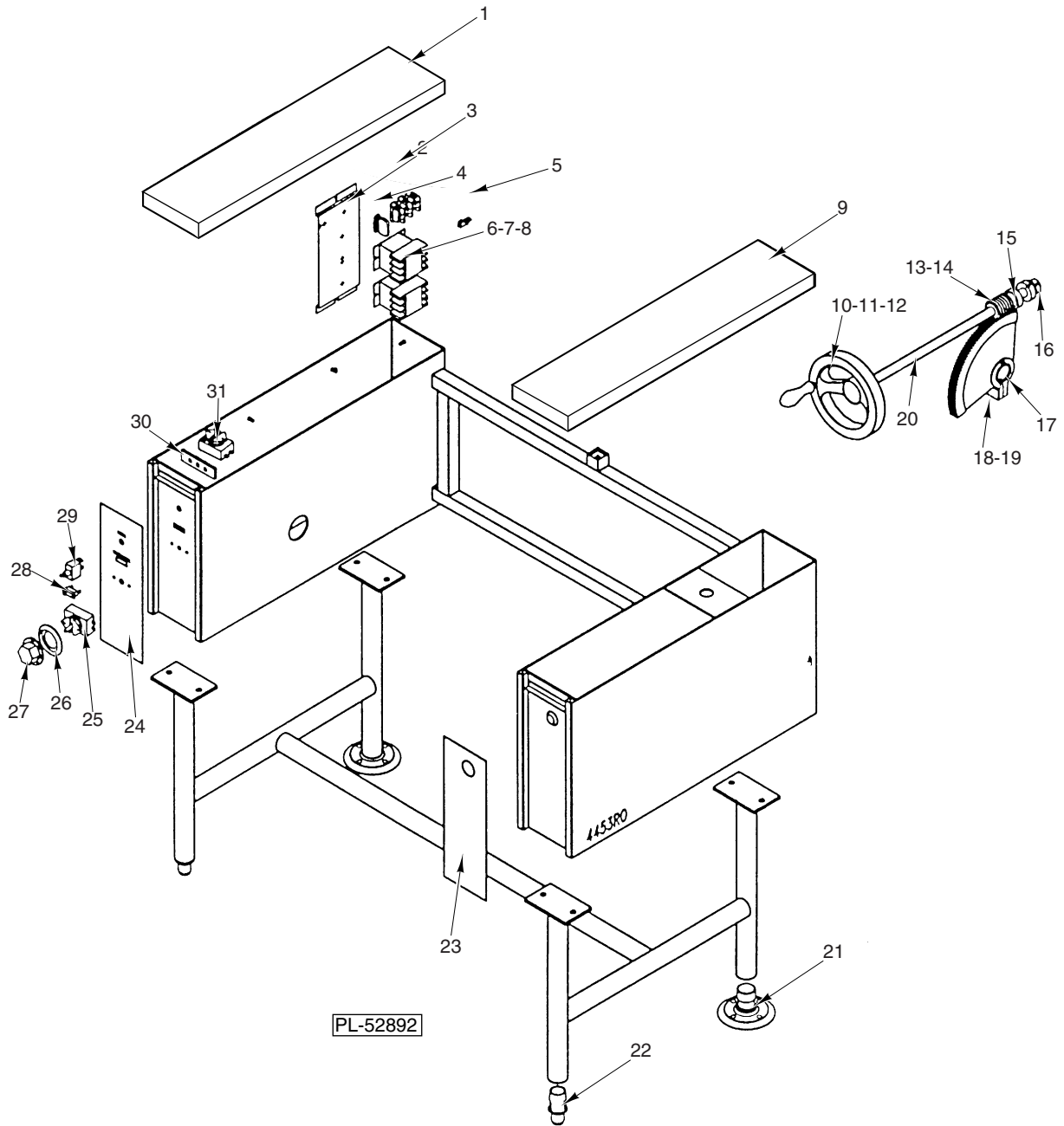

BASE ASSEMBLY

BASE ASSEMBLY

ILLUS. PL-52892	PART NO.	NAME OF PART	AMT.
1	00-850091	Cover - Console (L.H.)	1
2	00-851352	Plate - Component Mtg.	1
3	00-844367-00009	Block - Terminal (208/220/240)	3
4	00-844367-00010	Section - End	1
5	00-844367-00008	Lug - Ground	1
6	00-881974	Contactora (208V) (Select as Required)	2
7	00-881975	Contactora (220/240V)(Select as Required)	2
8	00-881975	Contactora (380/416/480V.)(Select as Required)	1
9	00-851523	Cover - Console (R.H.)	1
10	00-881962	Handerheel	1
11	00-851360	Label - Tilt	1
12	00-844458	Setscrew	1
13	00-881965	Gear Worm	1
14	00-836952	Pin - Tension	1
15	00-881963	Bearing - Thrust	2
16	00-844456	Jam Nut 3/4-16	2
17	00-850166	Key	1
18	00-881964	Gear - Segment	1
19	00-844457	Ring - Retaining	1
20	00-851361	Shaft - Tilt	1
21	00-836958	Foot - Flanged Adjustable (Rear)	2
22	00-851359	Foot - Front Adjust	2
23	00-851358	Decal - Console (R.H.)	1
24	00-851355	Decal - Operating	1
25	00-840467	Thermostat - Operating	1
26	00-844367-00005	Bezel	1
27	00-844063	Dial	1
28	00-881972	Pilot Light (Amber)	1
29	00-881970	Switch - Power	1
30	00-851354	Spacer - Thermostat	1
31	00-836832	Thermostat - Hi - Limit	1
	00-851322	Boot - Rubber	1
	00-851353	Bracket - Hi - Limit Mtg.	1
	00-843994	Transformer (480 Volt)(Select as Required)	1
	00-850489	Block - Fuse (380/415/480V)	2
	00-844546	Fuse (1 Amp, 600V, 380/416/480V)	2

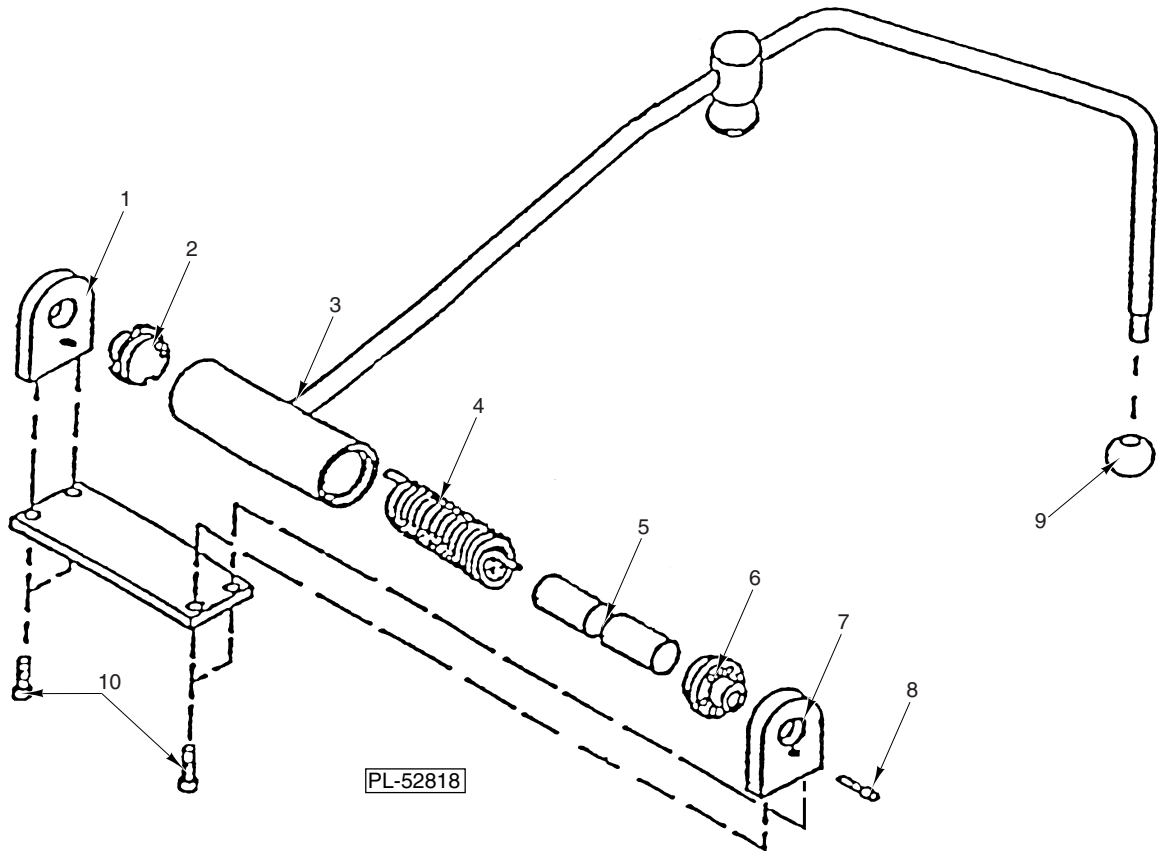

HANDLE ASSEMBLY

HANDLE ASSEMBLY

ILLUS. PL-52818	PART NO.	NAME OF PART	AMT.
1	00-844367-00046	End - Stop Plate	1
2	00-836992	Disc - Rotary	1
3	00-851529	Handle Assy.	1
4	00-836990	Spring	1
5	00-836989	Core	2
6	00-844367-00041	Disc - Stationary	1
7	00-844367-00040	End - Lock Plate	1
8	00-836986	Pin - Lock	1
9	00-836964	Knob	1
10	00-844367-00044	Cap Screw	4

