

MODEL 1T2018D 24 QUART TILTING STEAM KETTLE ON CABINET BASE



ANSI/NSF Standard #4

SPECIFICATIONS:

One 24 quart $\frac{2}{3}$ jacketed tilting steam kettle mounted on a 18" wide cabinet base, Vulcan-Hart Model No. 1T2018D. Steam jacketed kettle mounted on 28" high base cabinet with stainless steel frame, front full height door, stainless steel side rear panel with 6" adjustable legs with flanged feet for anchoring. Fully welded hemispheric bottom kettle with type 304 stainless steel jacket and type 316 stainless steel liner. Jacket tested to 50 psi (3.4 kg/cm²). Requires 21 lbs./1 hr. of steam flow at the kettle. Steam control valve on right trunnion leg. 12" single temperature deck mounted faucet.

Exterior dimensions: 18"w x 35.4"d x 28"h on 6" adjustable legs. Overall height to the lip of the kettle 47 $\frac{1}{2}$ ", to the top of the handle 56 $\frac{1}{4}$ ".

Classified by UL to NSF Std. #4. Meets ASME code.

- 1T2018D – 18" wide

STANDARD FEATURES

- One $\frac{2}{3}$ jacketed tilting steam kettle, 24 quart capacity.
- Steam jacketed kettle mounted on 28" high base cabinet with stainless steel frame, front full height door, stainless steel side rear panel with 6" adjustable legs with flanged feet for anchoring.
- Fully welded hemispheric bottom kettle with type 304 stainless steel jacket and type 316 stainless steel liner. Jacket tested to 50 psi (3.4 kg/cm²). Requires 21 lbs./hr. of steam flow per hour at the kettle.
- Steam control valve on right trunnion leg.
- 12" single temperature deck mounted faucet.
- One year limited parts and labor warranty.

OPTIONS

- Correction package.
 - Cabinet door with hasp (lock by others).
 - Security type tamper resistant fasteners.
- Tilting kettle strainer.
- 12" dual temperature faucet.
- Mount and interconnect kettle with boiler base at factory. Includes steam supply piping. Shipped on one skid.
- Second year extended limited parts and labor warranty.

ACCESSORIES

- Lift-off cover.
- Contour measuring strip.
- Single perforated stainless steel basket.
- Ball float trap.
- Pressure reducing valve.



MODEL 1T2018D

24 QUART TILTING STEAM KETTLE ON CABINET BASE

DIRECT STEAM DATA:

Steam supply to the kettles must:

1. Maintain a steady 13 psi flow under operating conditions.
2. Have a minimum flow rate of 21 lbs. (.6 BHP)/hr., dry steam.
3. Be adequately trapped to provide dry steam. (See ball float trap).

EQUIPMENT CLEARANCE:

Rear: 2" Right: 0" Left: 0"

CAPACITIES (in 4 oz. servings):

24 quarts / 6 gallons / 22.5 liters - 192 servings.

SERVICE CONNECTIONS:

S Steam Supply Connection: 3/4" NPT.

D Drain: Condenser box, compartment and boiler, 2" NPT. (Provide an open air gap type drain within 12" of condenser box and for best results at a distance so that steam vapors will not enter the steamer from underneath the control area. Do not connect solidly to any drain connection.)

W Water Supply Connection for kettle filler faucet: 1/4" NPT.

NOTE:

- Dimensions which locate the above connections have a tolerance of + or -3" (+ or -75 mm).
- Installation of backflow preventers, vacuum breakers and other specific code requirements is the responsibility of the owner and installer. It is the responsibility of the owner and installer to comply with local codes.
- Plastic drains are not recommended due to inherent limited temperatures of the plastic. Boiler purge temperatures may exceed 180°F. The installer may be required to provide means to reduce boiler purge water temperature to be that of the condensate temperature of 140°F or less.
- This appliance is manufactured for commercial installation only and is not intended for home use.

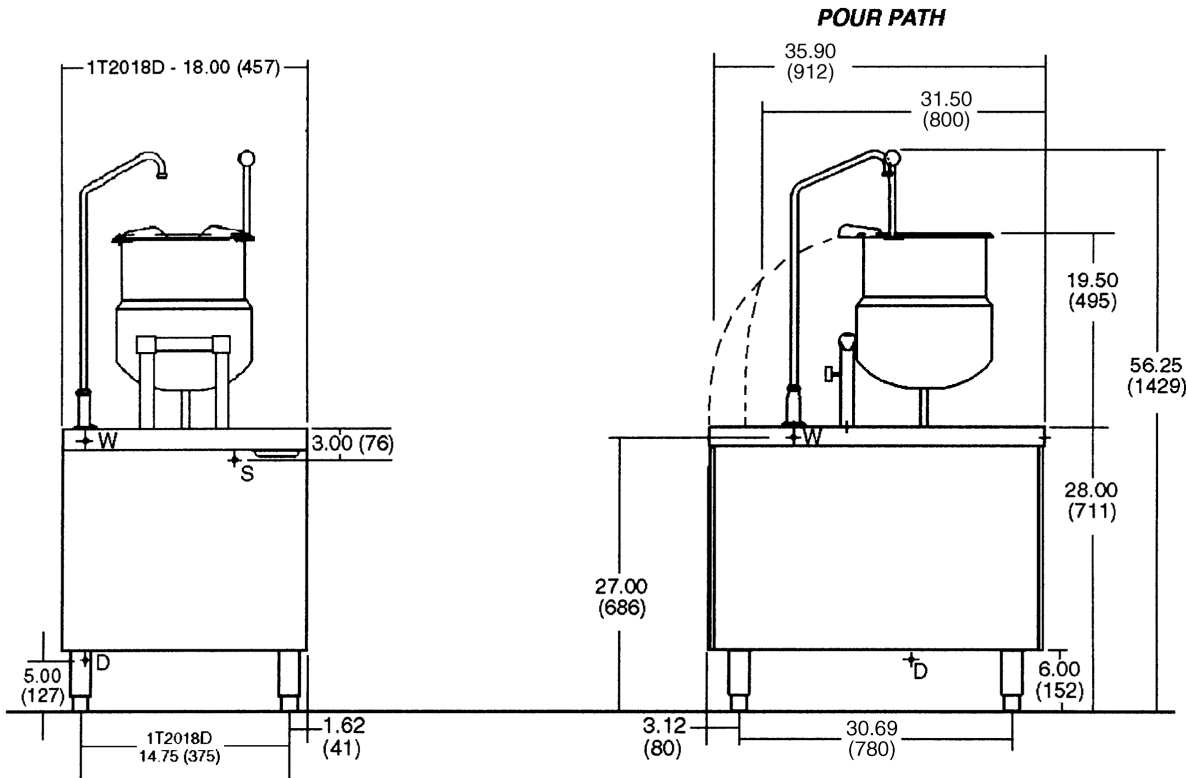
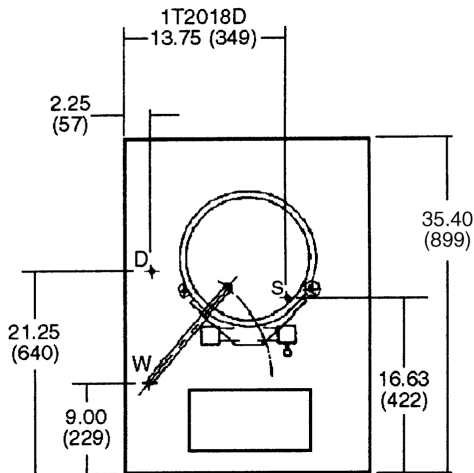

NOTE: In line with its policy to continually improve its products, Vulcan-Hart Company reserves the right to change materials and specifications without notice.