

# VULCAN

Item # \_\_\_\_\_

C.S.I. Section 11420

## MODEL 2T2036E

TWO 24 QUART  $\frac{2}{3}$  JACKETED TILTING  
KETTLES ON ELECTRIC BOILER BASE



### SPECIFICATIONS:

Two 24 quart  $\frac{2}{3}$  jacketed tilting steam kettles mounted on a 36" wide electric boiler base, Vulcan-Hart Model No. 2T2036E. Steam jacketed kettles mounted on 28" high base cabinet with front full height doors, slip-off stainless steel side and aluminized rear panel with 6" adjustable legs with flanged feet for anchoring. Fully welded hemispheric bottom kettle with type 304 stainless steel jacket and type 316 stainless steel liner. Jacket tested to 50 psi (3.4 kg/cm<sup>2</sup>). Steam control valve on right trunnion leg. 12" single temperature deck mounted faucet. Requires a 208 or 240 volt, 60 hz, 3 phase power supply and a separate 120 volt, 60 Hz, 1 phase control circuit, 3 amp.

### Exterior dimensions:

Cabinet: 36"w x 33"d x 28"h on 6" adjustable legs. Overall height to the lip of the kettles - 46", to the top of the handle - 54".

U L listed. Classified by U L to NSF Std. #4. Meets ASME Code.

### STANDARD FEATURES

- Two  $\frac{2}{3}$  jacketed tilting steam kettles, 24 quart capacity each.
- Steam jacketed kettles mounted on 28" high base cabinet with front full height doors, slip-off stainless steel side and aluminized rear panel with 6" adjustable legs with flanged feet for anchoring.
- Fully welded hemispheric bottom kettle with type 304 stainless steel jacket and type 316 stainless steel liner. Jacket tested to 50 psi (3.4 kg/cm<sup>2</sup>).
- Steam control valve on right trunnion leg.
- 12" single temperature deck mounted faucet.
- CSD-1 code compliant boiler.
- Electric 24 KW steam boiler.
- Requires a 208 or 240 volt, 60 Hz, 3 phase power supply and a separate 120 volt, 60 Hz, 1 phase control circuit, 3 amp.
- Water filter system, SPS620V. Includes second year extended limited water associated parts and labor warranty.
- One year limited parts and labor warranty.

### OPTIONS

- Correction package.
  - Cabinet door with hasp (lock by others).
  - Security type tamper resistant fasteners.
  - Front flanged feet.
- Stainless steel finishing back.
- Tilting kettle strainer (one) (two).
- 12" dual temperature faucet.
- Single phase on 24 KW boiler.
- Stepdown transformer (eliminates 120 volt connection).
- 36 KW boiler, 3 phase only.
- 42/48 KW boiler, 3 phase only.
- 480 volt, 60 Hz, 3 phase, includes stepdown transformer.
- Mount and interconnect kettle with boiler base at factory. Includes steam supply piping. Shipped on one skid.
- Second year extended limited parts and labor warranty.

### ACCESSORIES

- Stainless steel back panel.
- Lift-off cover (one) (two).
- Contour measuring strip.
- Single perforated stainless steel basket (one) (two).

VULCAN-HART COMPANY, P.O. BOX 696, LOUISVILLE, KY 40201, TEL. 1-800-814-2028  
502-778-2791 QUOTE & ORDER FAX: 1-800-444-0602



# MODEL 2T2036E

TWO 24 QUART <sup>2</sup>/<sub>3</sub> JACKETED TILTING  
KETTLES ON ELECTRIC BOILER BASE

**WATER QUALITY STATEMENT:**

The fact that a water supply is potable is no guarantee that it is suitable for steam generation. Your water supply must be within these general guidelines:

<b>SUPPLY PRESSURE</b>	20 - 60 psig
<b>HARDNESS*</b>	less than 3 grains
<b>SILICA</b>	less than 13 ppm
<b>TOTAL CHLORIDE</b>	less than 4.0 ppm
<b>pH RANGE</b>	7-8
<b>UN-DISSOLVED SOLIDS</b>	less than 5 microns

\* 17.1 ppm = 1 grain of hardness

Other factors affecting steam generation are iron content, amount of chlorination and dissolved gases. Water supplies vary from state to state and from locations within a state. Therefore it is necessary that the local water treatment specialist be consulted before the installation of any steam generating equipment.

**SERVICE CONNECTIONS:**

- A Electrical Connection for Boiler Heat:** Junction box see capacity chart.
- B Electrical Connection for Controls:** 120/60/1. 300 watt maximum, power supply with grounding wire required.
- C Drain:** Condensate box, compartment and boiler, 1/4" NPT. (Provide an open air type drain within 12" of condensate box and for best results at a distance so that steam vapors will not enter the steamer from underneath the control area. Do not connect solidly to any drain connection.)
- D Cold Water Connections (2):**
  - D1 Treated Cold Water Connection:** 1/4" NPT for boiler feed. Inlet water pressure between 20 and 80 psi.
  - D2 Untreated Cold Water Connection:** 1/4" NPT for condensate box. Inlet water pressure between 20 and 80 psi.

KW INPUT	AMPS PER LINE					
	1 PHASE		3 PHASE			3 PHASE-4 WIRE 220/380V 240/415V
	208V	240V	208V	240V	480V	
24	116	100	67	58	29	34
36	NA	NA	100	87	44	50
42	NA	NA	117	NA	NA	NA
48	NA	NA	NA	116	58	67

**E Water:** For swing faucet, (single) (dual) temperature, 1/4" tubing.

**NOTE:**

- Dimensions which locate the above connections have a tolerance of + or -3" (+ or -75 mm).
- Installation of backflow preventers, vacuum breakers and other specific code requirements is the responsibility of the owner and installer. It is the responsibility of the owner and installer to comply with local codes.
- Plastic drains are not recommended due to inherent limited temperatures of the plastic. Boiler purge temperatures may exceed 180°F. The installer may be required to provide means to reduce boiler purge water temperature to be that of the condensate temperature of 140°F or less.
- This appliance is manufactured for commercial installation only and is not intended for home use.

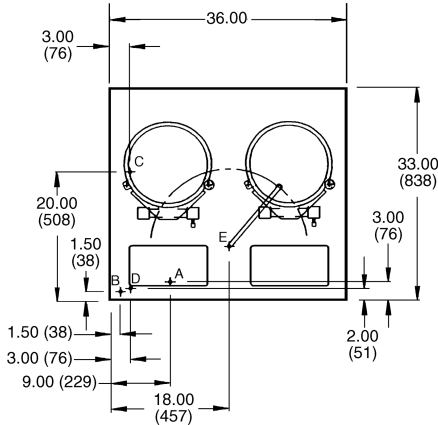

**EQUIPMENT CLEARANCE:** Rear: 2" Right: 0" Left: 0"

**BRIMFUL CAPACITIES (in 4 oz. servings):**

24 quarts / 6 gallons / 22.5 liters - 192 servings.

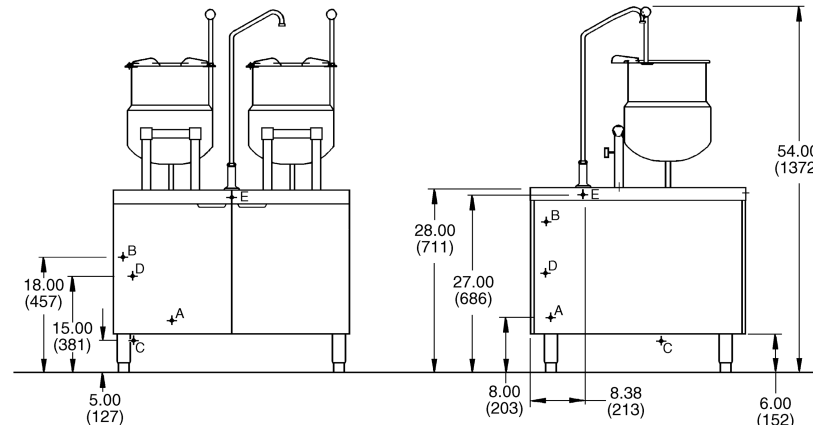

**NOTE:** In line with its policy to continually improve its products, Vulcan-Hart Company reserves the right to change materials and specifications without notice.