



TECHNIQUE

COMBI OVENS

MINIJET “FastPAD”

ELECTRIC

MANUFACTURERS INSTRUCTIONS

Part D: Maintenance manual

- WARRANTY -

To ensure the guarantee on this equipment, you should comply with the MANUFACTURER'S INSTRUCTIONS in this manual.

However if you cannot undertake the required maintenance operations, our installation and service network is available to provide you with a personalized contract.

- WARNING -

- The product delivered to you complies with current standards. If any modifications are made the manufacturer cannot accept any responsibility whatsoever. The manufacturer cannot be held responsible in the event of an incorrect use of the appliance.

- Keep your documents.
- Translation of the original manual

CONTENTS

COMBI OVENS

MINIJET “FastPAD”

1	ELECTRICAL DIAGRAMS	3
1.1	LIST OF PARTS	3
1.2	MINIJET	4
2	PROGRAMME SETTINGS	6
2.1	SETTING THE SOFTWARE LANGUAGE.....	6
2.2	OVEN SETTINGS.....	6
2.3	WATER TREATMENT COUNTER	8
3	MAINTENANCE PROGRAMMES	9
3.1	ELECTRONIC CARDS	9
3.2	CHECKING THE SOFTWARE VERSION	11
3.3	POSITION OF THE MICRO SWITCHES ON A FASTPAD 2 POWER UNIT.....	11
3.4	UPDATING THE SOFTWARE	12
4	MAINTENANCE SCREENS	13
4.1	ACCESS TO THE MAINTENANCE SCREENS	13
5	ERROR MESSAGES	15
5.1	ERROR SCREENS.....	15
5.2	ERROR MESSAGES.....	15
6	HYDRAULIC DIAGRAMS	19
6.1	MINIJET OVENS	19
7	PREVENTIVE MAINTENANCE	20
7.1	LIST OF ACTIONS	20
7.2	WORKING ON THE DETERGENT PUMPS.....	21
8	PROCEDURE FOR CHANGING COMPONENTS	22
8.1	LOCATION OF TECHNICAL COMPONENTS	22
8.2	ACCESS TO COMPONENTS	22
8.3	CODER	23
8.4	SCREEN CARD.....	23
8.5	RELAY CARD (complete assembly with box)	24
8.6	LED STRIP (IN THE DOOR)	25
8.7	CLOSING MECHANISM.....	25
8.8	INTERNAL GLASS	25
8.9	DOOR CATCH.....	26
8.10	DOOR	26
8.11	VENT VALVE MOTOR	26
8.12	FLOW METER.....	27
8.13	TEMPERATURE PROBE	27



VULCAN

A division of ITW Food Equipment Group LLC

P.O. Box 696

Louisville, KY 40201

8.14 CLEANING PRODUCT PUMP27

8.15 HEATING ELEMENT28

8.16 FAN28

8.17 MOTOR SEAL.....29

8.18 MOTOR.....29

8.19 CAVITY SEAL29

9 CHECKING THE TEMPERATURE SENSORS..... 30

9.1 PT100 PROBE30

10 FRONT LINE PARTS 32



VULCAN
A division of ITW Food Equipment Group LLC
P.O. Box 696
Louisville, KY 40201

1 ELECTRICAL DIAGRAMS

1.1 LIST OF PARTS

Designation of common parts

Ref.	Designation	Characteristics	Quantity	Code
Af	FastPAD screen card		1	309634
Ar	FastPAD II maxi relay card		1	309665
B1	Capacity sensor PT 100		1	301471
Bd	Volumetric doser	Flow meter	1	314374
Cm1	Condenser 12.5 μ F		1	304296
Ee	Lighting lamp	LED strip	1	309638
F1	Fuse 3.15 Amps		1	309407
F2	Fuse 1 Amps time delay		1	309789
F3	Fuse 10 Amps time delay		1	300788
F4	Fuse 0.2 Amps speed ultra fast fuse		1	300787
F5	Fuse 3.15 Amps		1	309407
F6	Fuse 2 Amps		1	300790
F7	Fuse 1 Amps time delay		1	300789
F8	Fuse 0.25 Amps time delay		1	300791
F9	Fuse 10 Amps		1	300793
Fc	Safety thermostat		1	301066
Fm1	Ventilator motor sensor		1	-
FPdm	Pump thermostat		1	-
M1	Ventilation motor		1	304295
Mo	Motorised Vent valve motor		1	305110
Mt1	Technical ventilator		1	304297
Mt2	Technical ventilator		1	304297
Pdn	Dosing pump	Descaler	1	314379
Te	Transformer		1	308350
Ta	Transformer		1	308491
Tmo	Transformer	230V/24V	1	308492
Rc1	Heating elements 6 kW Diam 340		1	302276
Sp	Reed bulb (Flexible blade switch)	Door closing safety system	1	300676
Xa	Supply terminal strip		1	306087
Xb	Supply terminal strip		1	-
Xsc	Core probe terminal strip		1	301477
	Silicone cover		1	366554
Za	Supply filter		1	309639

List of contactors

Ref.	Designation	Minijet 230V	Minijet 400V	Code
Kr	Cavity heating contactor	1	1	300 698
Ks	Safety contactor	1	1	300 698
Zr	Interference suppressor	1	1	300 769
Zs	Interference suppressor	1	1	300 769



VULCAN

A division of ITW Food Equipment Group LLC
P.O. Box 696
Louisville, KY 40201

1.2 MINIJET

WIRING DIAGRAM

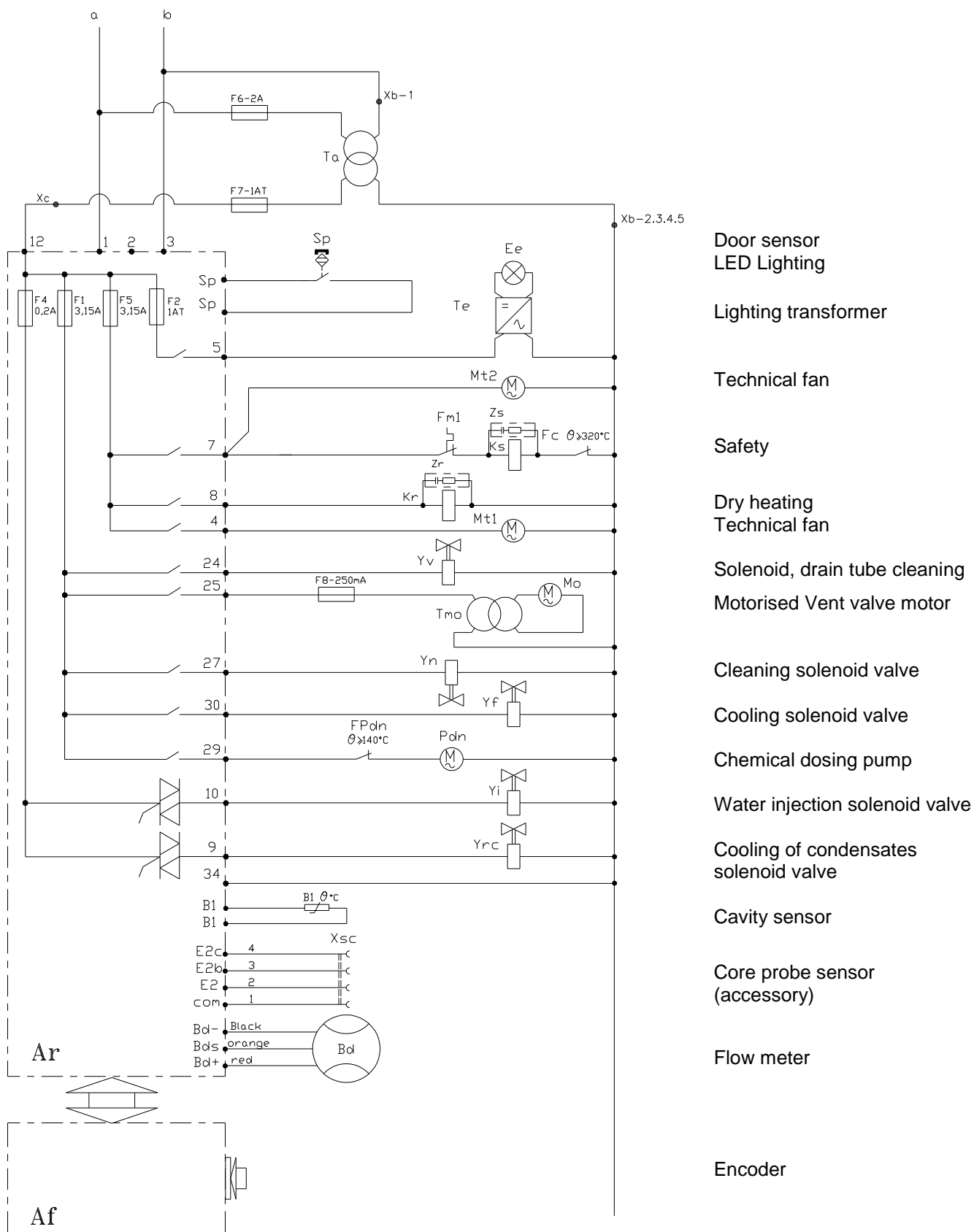

POWER DIAGRAM

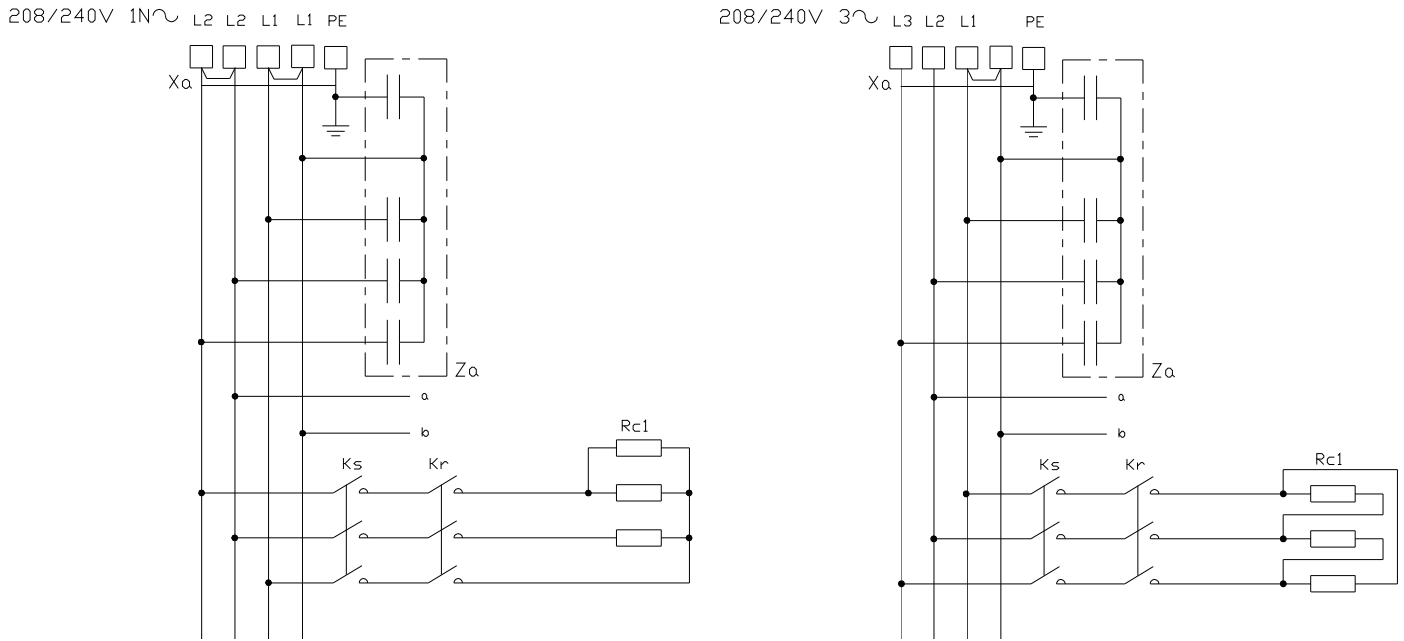

CAVITY VENTILATION SINGLE-PHASE DIAGRAM WITH AUTO REVERSE

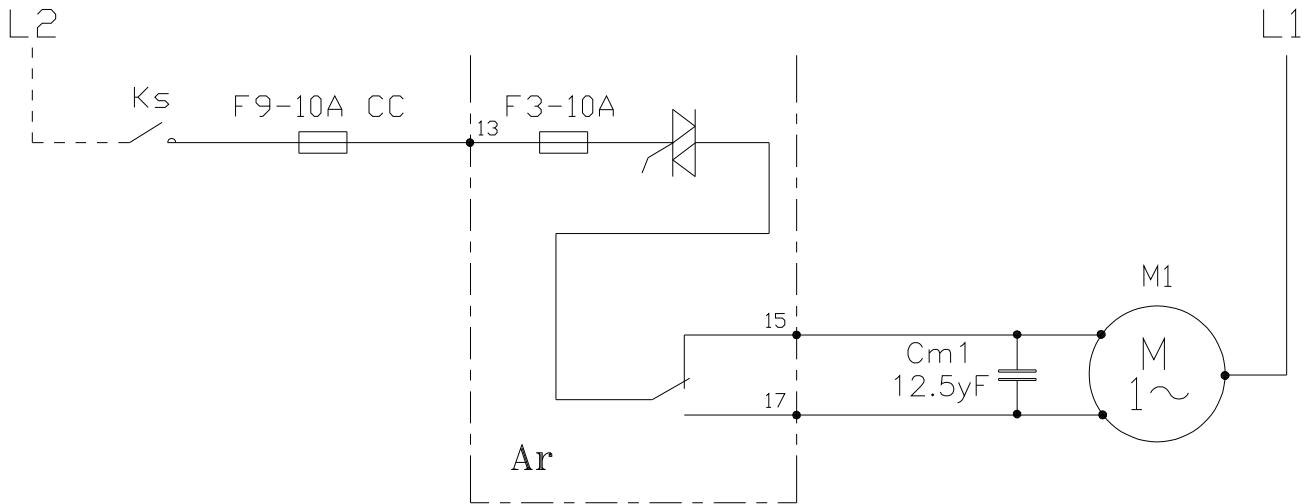

2 PROGRAMME SETTINGS

This is required if a relay card, or a facia card is changed or there is an upgrade of the FastPAD software. Before programming check the software is in the local language and change if necessary.

2.1 SETTING THE SOFTWARE LANGUAGE

- Go into the "TOOL BOX" screen
- Select the "Client parameters" screen
- Enter the password "CHEF" Permanent pass word (Upper or lower case)
- Validate "V": if the code is correct the menu can be accessed if not return to inputting the PIN
- Modify the programme language if necessary (Fr: French by default)
 - * Select the zone to be modified
 - * Adjust the value using the coder.



2.2 OVEN SETTINGS

- Go into the "TOOL BOX" screen
- Select the "Technical parameters" screen
- Enter the password "SAVB" password
- Validate "V": if the code is correct the menu can be accessed if not return to inputting the PIN
- Reconfigure the oven
 - * Select the zone to be modified
 - * Adjust the value using the coder.



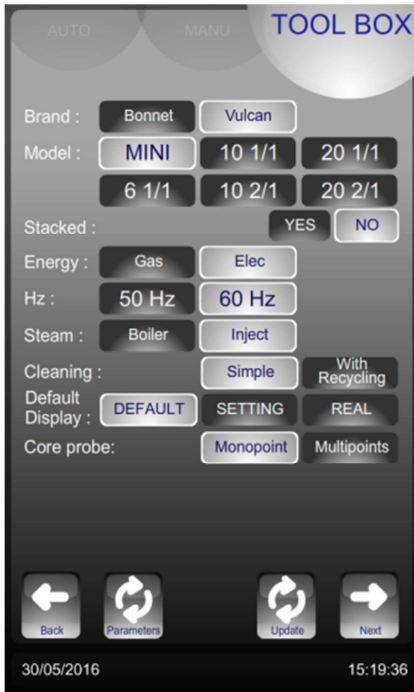

- Commercial identification of the oven
- Model: Number of levels and size. Minijet = 6 1/1
- ← Download on USB error message history (file extension compatible with Excel)
- ← Download on USB counters (file extension compatible with Excel)

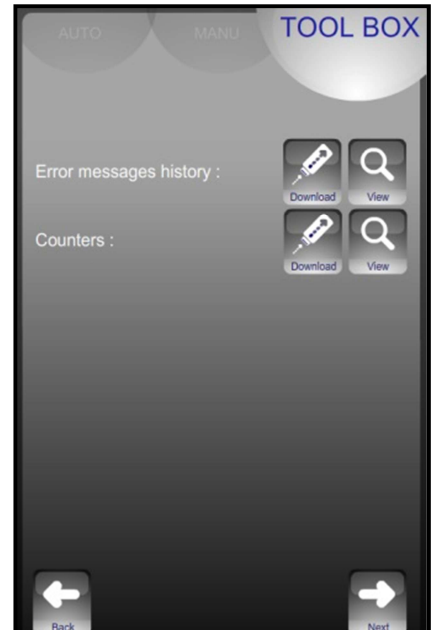

Error message history



- Display of error messages in the order that they appeared
- ← List of counters
- Quality of communication signal between the facia and relay cards
For a signal strength < 85% see fault E46
- Pressing the «Back» button returns to the previous menu screen

Counters

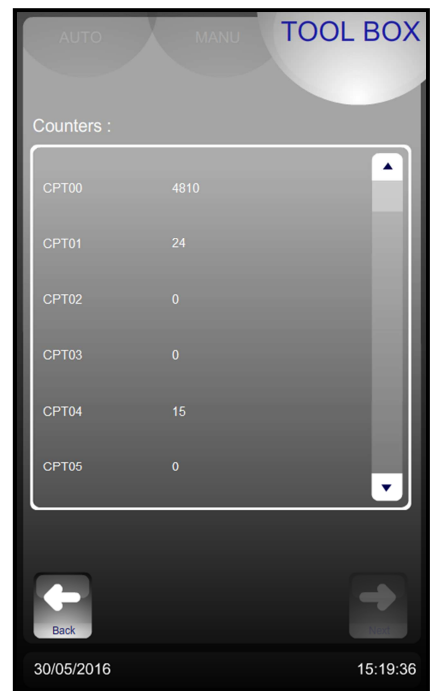

Counters

CPT00:	Total operating time in hours
CPT01:	Time of cooking in Convection mode in hours
CPT02:	Time of cooking in Steam mode in hours
CPT03:	Time of cooking in Combi mode in hours
CPT04:	Number of door openings
CPT05:	Number of activation of the Gas security inlet (number of E67 error occurrences)

CPT06:	Operating Time with electronic >70°C in hours
CPT07:	Operating Time of S21 outlet in hours
CPT08:	Operating Time of S10 outlet in hours
CPT09:	Operating Time of S30 outlet in hours



VULCAN
 A division of ITW Food Equipment Group LLC
 P.O. Box 696
 Louisville, KY 40201

2.3 WATER TREATMENT COUNTER

This only functions if there are 2 separate supplies to the oven.

- Open the service tab
- Select the Client parameters button
- Enter the "CHEF" PIN code « permanent » (lower or uppercase)
- Validate "V": When entered if the code is correct access the menu, if not re-enter the PIN code.



Water treatment capacity

- To modify or enter the value for the capacity of the water treatment system (in litres). Set to zero by default (if the oven does not have a dedicated water treatment system).
 - * Select the zone to be changed
 - * Adjust with the coder knob.
- After any regeneration of the water treatment, reset the counter as required.
 - * Press « RESET »
 - * Confirm by pressing « YES »

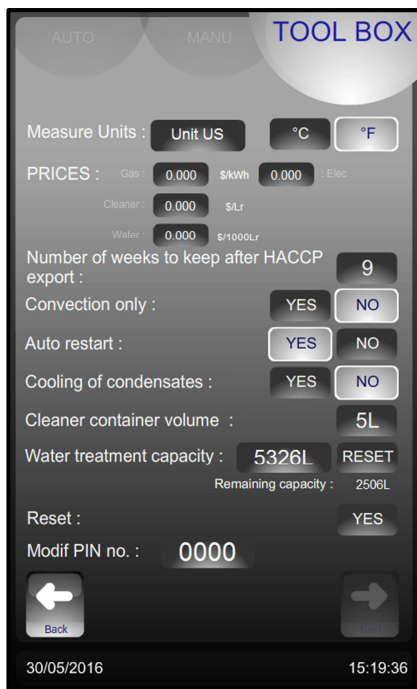

→ The water treatment system's capacity in litres
Reset.
By default set to zero (if there is no dedicated treated water supply to the oven)

3 MAINTENANCE PROGRAMMES

3.1 ELECTRONIC CARDS

The state of the LEDs represent the communication between the electronic cards and helps with diagnostics in the event of a breakdown

3.1.1 RELAY CARD

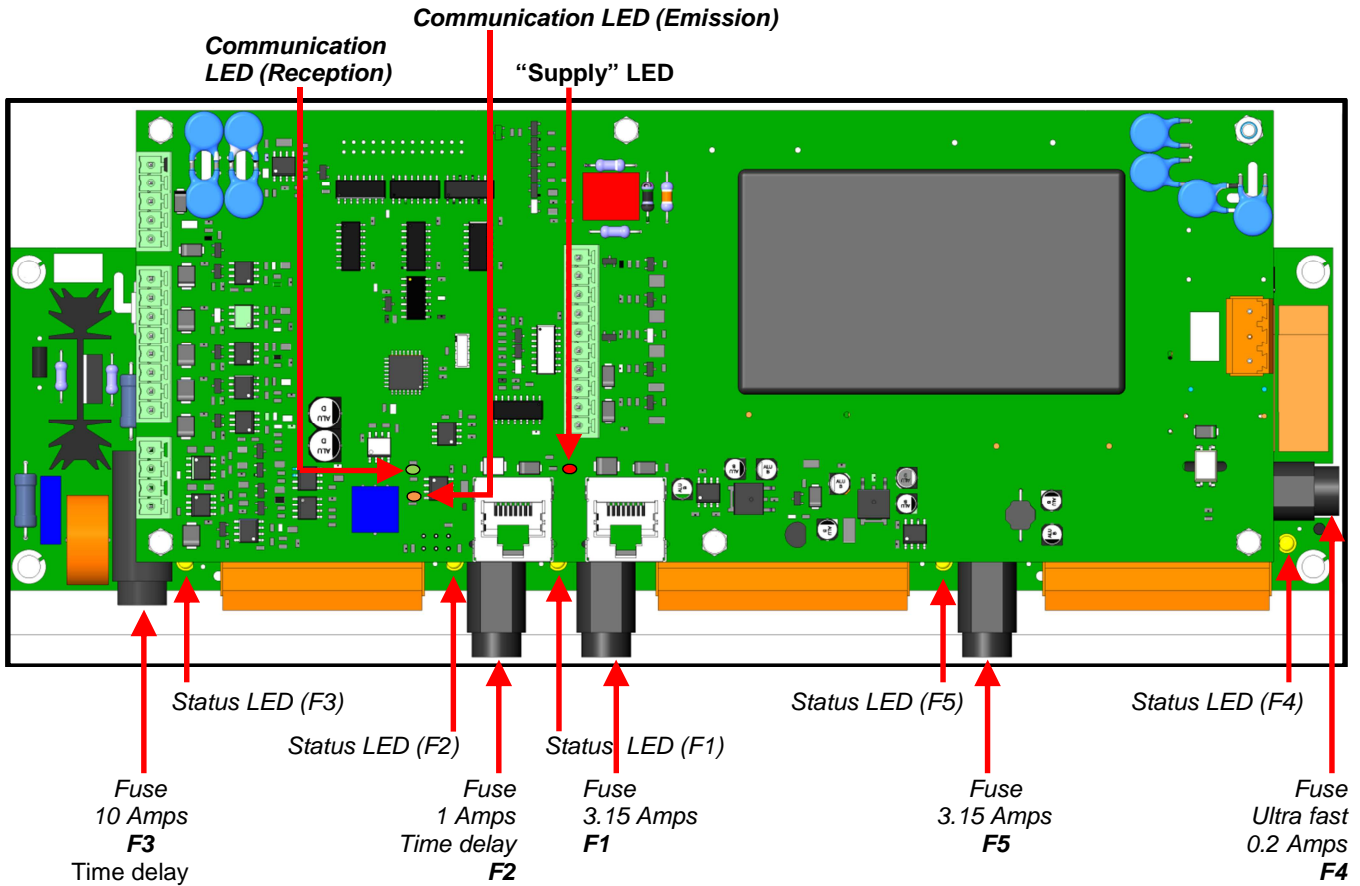

Identification of the LEDs for communication, supply and safeties and the fuses on the card.

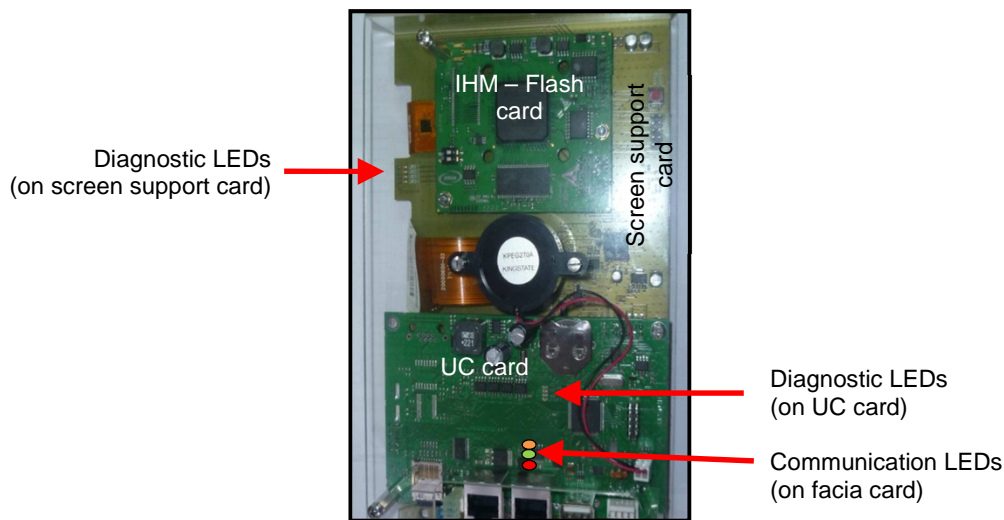

3.1.2 SCREEN CARD











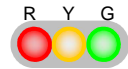

Significance of the LEDs on the electronic relay card and the graphic facia card:

	LED Red → → →	Power on	LED steady LED steady or flashing
	LED yellow/Orange →	Emitting	
	LED Green → → →	Receiving	

A flashing LED is considered active as is a steady one.

Diagnostic of electronic faults (communication LEDs):

Facia card	Relay card	Diagnostic	Actions
		- Relay card OK - Facia card OK	- Functioning normally
		- Supply fault	- Check the voltage between terminals 1 and 3 on the relay card
		- Problem communicating with the screen	- Replace the screen and/or the cable between the cards
		- Primary card (of relay card) non function	- Replace the primary card (the relay card)
		- Screen non function	- Replace the screen
		- Cable between screen and relay cards	- Replace the interconnecting cable

3.1.2.1 UC CARD

State of LEDs at start up:

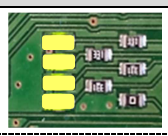
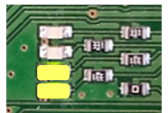

LED state	Diagnostic	Actions
 At systems start up (Power switched on) the 4 LED light up then go out successively	- Normal function	
 If one or more remain illuminated after the screen comes on	- UC card non function	- Replace the UC card

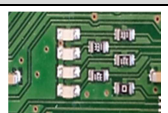
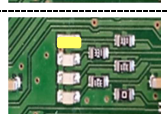
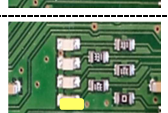
State of LEDs whilst in operation:

LED state	Diagnostic	Actions
 All 4 LEDs out	- Normal function	
 LED 1 flashes	- Communication fault with the relay card	- Check the wiring and connection of the RJ45 cable If the fault remains, change the relay card
 LED 4 flashes	- Communication fault with the IHM - Flash card or with the screen	- Change the IHM – Flash card If the fault remains, change the screen

3.1.2.2 SCREEN SUPPORT CARD

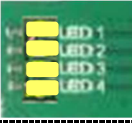
State of LEDs at start up:

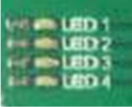
LED state	Diagnostic	Actions
 All 4 LEDs lit	- IHM - Flash card non function	- Replace the IHM – Flash card
 LED 1 and 2 flash LED 3 and 4 lit	- UC card non function	- Replace the UC card
 No screen display All 4 LEDs out	- Screen support card non function	- Replace the screen support card
 All 4 LEDs out	- Normal function	

3.2 CHECKING THE SOFTWARE VERSION

The version of software can be seen in the “TOOLBOX” tab next to the serial number of the unit. Each card is identified together with its software number:

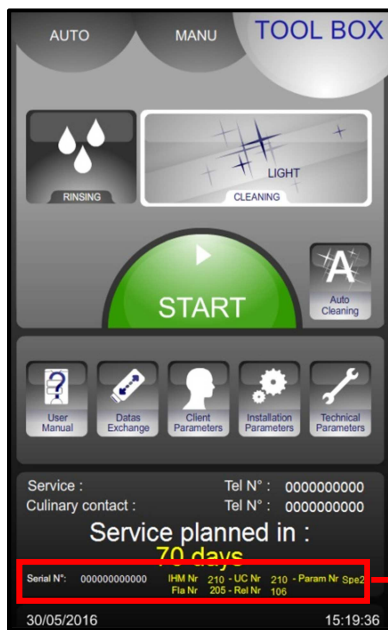

Screen card sub assembly
IHM - Fla : IHM – Flash card
UC : UC card
 Screen support card

Relay cards

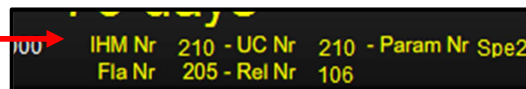

3.3 POSITION OF THE MICRO SWITCHES ON A FASTPAD 2 POWER UNIT

The position of these micro-switches ensure the automatic recognition by the interface of the type of unit so appropriate software is installed (after sales or initialization)

Micro-switch positions

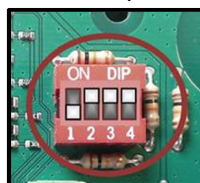

Oven model

Minijet “FastPAD”

3.4 UPDATING THE SOFTWARE



Attention:

It is vital that the electrical supply is not switched off whilst loading software.
The USB stick must not be removed whilst loading software

Connect the USB stick that has the new software on it.

The USB port has a protective silicone cover.
 It is located to the left or right of the control panel.

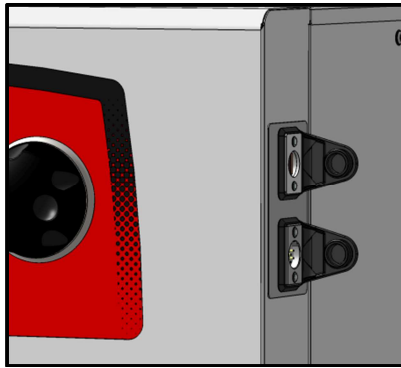

USB port

Core probe socket



Attention!

Put the protective covers back in place if the sockets are not being used.

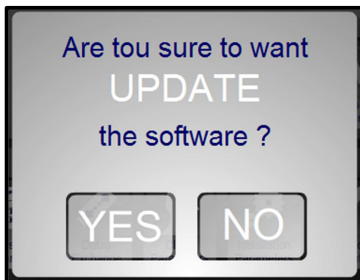

Plug the USB stick into the port
 Switch the power back on
 The update screen will appear.

If this screen does not appear it is because the software on the USB stick and the software in use are the same

Select YES: The software will start to load
 Loading is complete when the unit restarts
 Remove the USB stick from it.

Undertake the software check described previously "Checking the software version" to ensure the new software has loaded correctly

This is required if a relay card, or a facia card is changed or there is an upgrade of the VisioPAD software.
 Before programming check the software is in the local language and change if necessary.

4 MAINTENANCE SCREENS

Once you are sure the 2 electronic cards are functioning and with information from the client and the error messages displayed activate the diagnostic assistance module which consists of 3 screens.

This will allow you to control the input and output devices and peripherals feeding the cards:

- Screen 1 gives control of temperature, door, water level.
- Screen 2 gives control of outputs to ventilation, heating, lighting, safety contactor, the vent outlet
- Screen 3 gives control of the hydraulics outputs, solenoids, wash pump and wash tank.

4.1 ACCESS TO THE MAINTENANCE SCREENS

- Go into the "TOOL BOX" screen
- Select the "Technical parameters" screen
- Enter the password "SAVB" password
- Validate "V": if the code is correct the menu can be accessed if not return to inputting the PIN
- Press "Next". Scroll through the different screens using the "Next" button



4.1.1 ENTRY SCREEN

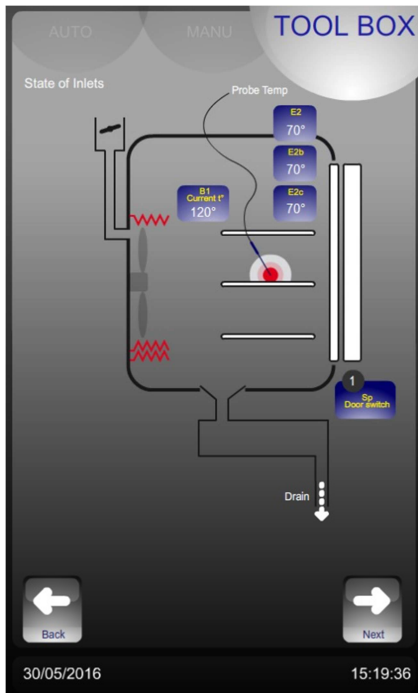

Entries	Normal status	Remarks
B1	Cavity temperature	-
E2-E2b-E2c	Core probe temperature	-
Sp	Opened door= 0 Closed door = 1	-

4.1.2 HYDRAULIC OUTPUT ACTIVATION SCREEN

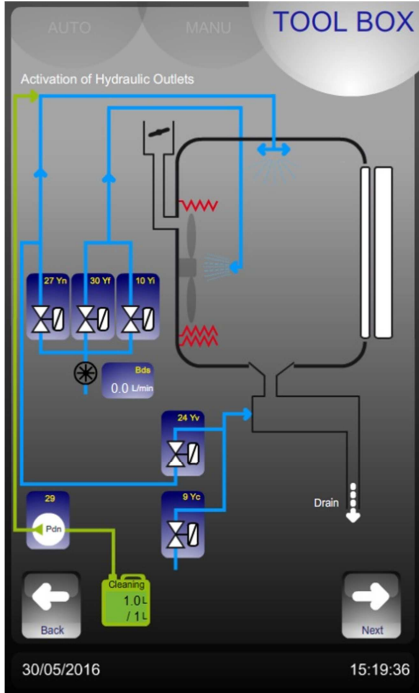

Key	Relay card outlet Nbr	Component	Operation
Pdt	29	Chemical dosing pump	one press = 0.5s of operation
Pdt	27	Cleaning solenoid valve	one press = 0.5s of operation
Pdn	24	Drain solenoid valve	one press = 0.5s of operation
Yf	30	Cool solenoid valve	one press = 1min of operation
Yi	10	Water injection solenoid valve	one press = 1min of operation
Bds	Bds	Flow sensor	Indication of the current flow rate
Yc	9	Drain cooling solenoid valve	one press = 1min of operation

one press = 0.5s of operation

4.1.3 ELECTRIC OUTPUT ACTIVATION SCREEN

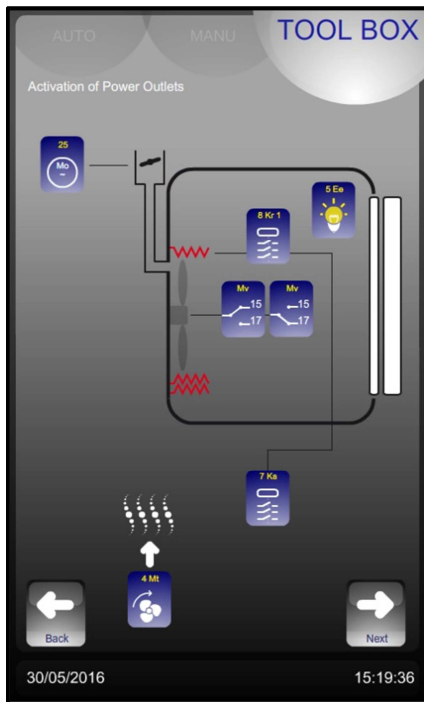

Key	Relay card outlet nbr	Component	Operation
Mo	25	Vent motor	One press = on / one press = off
Ee	5	Cavity lighting	One press = 0.5s of operation
Kr1	8	Contactor	One press = 0,5s clockwise
Mv	15	Fan cavity motor	One press = 0,5s anticlockwise
Mv	17	Fan cavity motor	one press = 0.5s of operation
Ks	7	Safety contactor	One press= on / one press = off
Mt	4	Technical fan	

5 ERROR MESSAGES

5.1 ERROR SCREENS

*Green screen:
Information on the cooking*

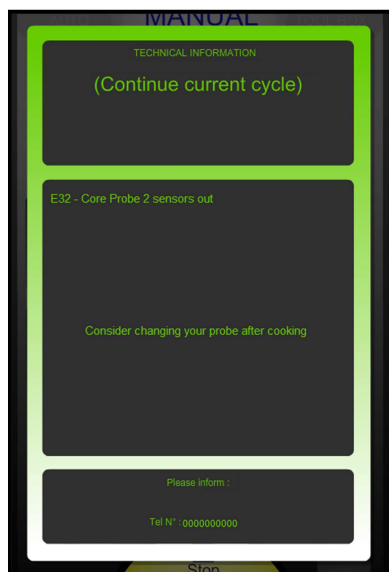

*Yellow screen:
Alternative operation*

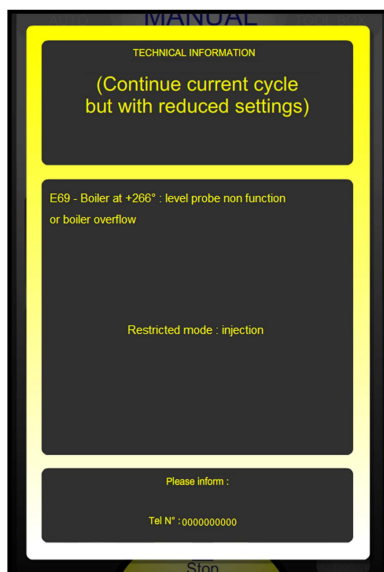

*Red screen:
Cooking stopped (pause)*

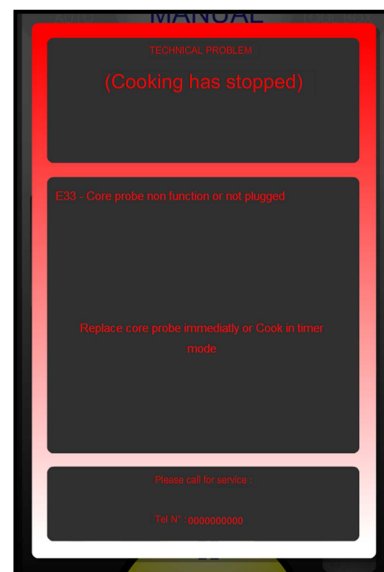

Possibility to recover the process after correction of the error

5.2 ERROR MESSAGES

Message on the screen Consequences	Probable cause	What to do ?
i28 : Core probe not connected		
Cooking stops Waiting for a Core probe to be connected or to switch to timer mode	Core probe not connected or faulty	Connect the probe and check the value of E2 using the input screen. Si "--", disconnect E" from the card. Check the values of the PT 100 probe on the terminal screws (see corresponding table and details). If the values are incorrect change the probe. If not check the connections or change the relay card.
E30 : Electronics overheating		
Electronics overheating, cooking continues	Drawing in hot air ----- Air inlet obstructed ----- Technical cooling fan clogged or not functioning	Installation problem: check for heated units nearby (Solid top, open burners,...) ----- Clean the air vents at the front and rear of the oven ----- In (TECH parameters) screen for outputs activate No 4 (Mt). Check that there is power to the fan using a multi tester. If there is power replace the fan. If not replace the relay card.
i31 : Electronics overheating: Temperature reduced to 356°F		
Electronics overheating: Temperature reduced to 356°F	Exactly as error E30	Exactly as error E30

Message on the screen Consequences	Probable cause	What to do ?
i33 : Core probe non function or not plugged		
Cooking stops Waiting for a Core probe to be connected or chefs decision	Core probe disconnected during a cooking cycle. or faulty ----- Faulty core probe	Check the core probe connections. ----- Connect the probe and check the value of E2 using the input screen. Si "--", disconnect E" from the card. Check the values of the PT 100 probe on the terminal screws (see corresponding table and details). If the values are incorrect change the probe. If not check the connections or change the relay card.
E46 : Electronic communication fault (Bus RS485)		
Cooking stops Cooking possible with reduced functionality at up to 347°F.	Loss of communication between the relay card and the facia	Check the connection and state of the Ethernet cable between the relay card and the screen. Replace the cable if necessary. Check the status of the communication LEDs on the two cards. See the page detailing the significance of the LEDs on the relay and graphic facia card
E53 : Short circuit of coil or motor or ventilation non function		
Cooking stop	F5 blown	
	Short circuit or fault in the technical ventilation fan	Check the state of the LED near to the fuse. If it isn't on check outputs S4, S7 and S8 on the card using an ohmmeter to find the short circuit. If this is the case replace the defective component (technical fan or contactor). Replace fuse F5 and check the fault has cleared by activating the outputs in (TECH parameters).
	F3 blown	
	Fan motor defective	Check the state of the LED near to the fuse. If it isn't on check the motor, measure the resistance and coil insulation. Replace if necessary and change fuse F3.
	F5 and F3 not blown and E53 permanently displayed	
	Contactors Ks doesn't hold in during the oven initialisation when the door is closed	Motor klaxon disengaged: Test the klaxon with an ohmmeter when the fault appears, replace the motor if necessary. Check for power to the coil on contactor Ks. If there is power replace the contactor or the card.
Contactors Ks holds in during the oven initialisation when the door is closed	Check for power to terminal 13 on the relay card: If there is power connect wires 13 and 15 restart the oven, the motor should start when the oven is switched on. If so, change the relay card if not check all connections to the motor or change the motor.	
E53 appears after a certain time operating		
Motor klaxon opens when hot (Defective motor)	Check that the motor turns freely (no rubbing or abnormal noise). Check current and resistance to the coils. Replace the motor if necessary. Motor klaxon disengaged: Test the klaxon with an ohmmeter when the fault appears, replace the motor if necessary.	
E61 : Ambient probe short circuit		
Cooking stop	Cavity temperature probe poorly connected (connection to relay card)	Check what temperature the probe is reading in the inputs screen (TECH parameters) Check the wires are tightened on connection B1 on the relay card.
	Probe short circuited	Check what temperature the probe is reading in the inputs screen (TECH parameters) Disconnect (B1) from the card. Check the value of the PT 100 probe on the terminal screws (see the table for corresponding values). If incorrect change the probe, if the probe is functioning replace the relay card.

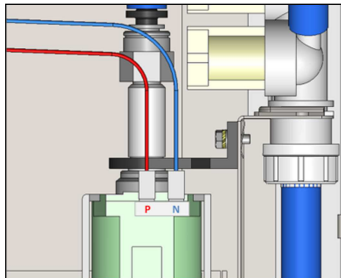
Message on the screen Consequences	Probable cause	What to do ?
E62 : Ambient probe faulty or poorly connected		
Cooking stop	Cavity temperature probe poorly connected (connection to relay card)	Check what temperature the probe is reading in the inputs screen (TECH parameters) Check the wires are tightened on connection B1 on the relay card
	Probe wiring broken	Check what temperature the probe is reading in the inputs screen (TECH parameters) Disconnect (B1) from the card. Check the value of the PT 100 probe on the terminal screws (see the table for corresponding values). If incorrect change the probe, if the probe is functioning replace the relay card.
E68 : Cavity at +554°F		
Cooking stop	Heating contactor welded shut	Power off, check if Kr is permanently engaged. If so replace it. If not check the output from the relay card working using the output activation in (TECH parameters) If Kr remains engaged replace the relay card.
E72 : Electronics at over + 167°F		
Cooking stop	Exactly as error E30	Exactly as error E30
E73 : Detergent pump faulty or on permanently		
Cooking stop	Pump is on when a cleaning cycle is not running	
	Relay card is stuck on or detection electronics not working	Check if the pump is running all the time after the oven is turned on. If so replace the FastPad relay card.
	Relay card is stuck on or detection electronics not working	Open circuit Check if the pump is running all the time after the oven is turned on. If so replace the FastPad relay card.
	Pump badly connected	Pump working Check the connections for Phase and Neutral to the pump.
		
i81 : Water flow problem		
	Fuse F1 blown	Using an ohmmeter check outputs S24, S25, S27, S29, S30 on the card to find the short circuit. If this is the case replace the defective component(s). Check the outputs via the activation screen in (TECH parameters) Replace the relay card if necessary.
	Fuse F4 blown	Using an ohmmeter check output S10 on the card for a short circuit. If this is the case replace the solenoid. Check S10 output via the activation screen in (TECH parameters) Replace the relay card if necessary.

Message on the screen Consequences	Probable cause	What to do ?
i81 : Water flow problem		
Cooking will be degraded.	Water supply problem	Check the water supply to the unit: minimum flow 5 litres/minute and minimum pressure 1.5 bars. Check that the filter isn't clogged and the state of the pressure limiter. Check the state of the flow limiters
	Solenoid has failed	Check solenoids Yi, Yf, and Yn S10, S30 and S27 from the output activation screen in (TECH parameters) Measure the volume of water recovered in 1 minute.
	Flow meter non function	Check the amount being recorded by the flow meter in the input status screen in (TECH parameters). Replace it if necessary.
E82 : Solenoid letting by		
Cooking will be degraded	Solenoid letting by	Check solenoids Yi S10, Yf, S30, and Yn S27, replace them if necessary.
	Flow meter non function	Check the amount being recorded by the flow meter in the input status screen in (TECH parameters). Replace it if necessary.
	Relay card not working	Check the power on outputs S10, S27 and S30. If power is detected outside a cooking cycle replace the relay card.

6 HYDRAULIC DIAGRAMS

6.1 MINIJET OVENS

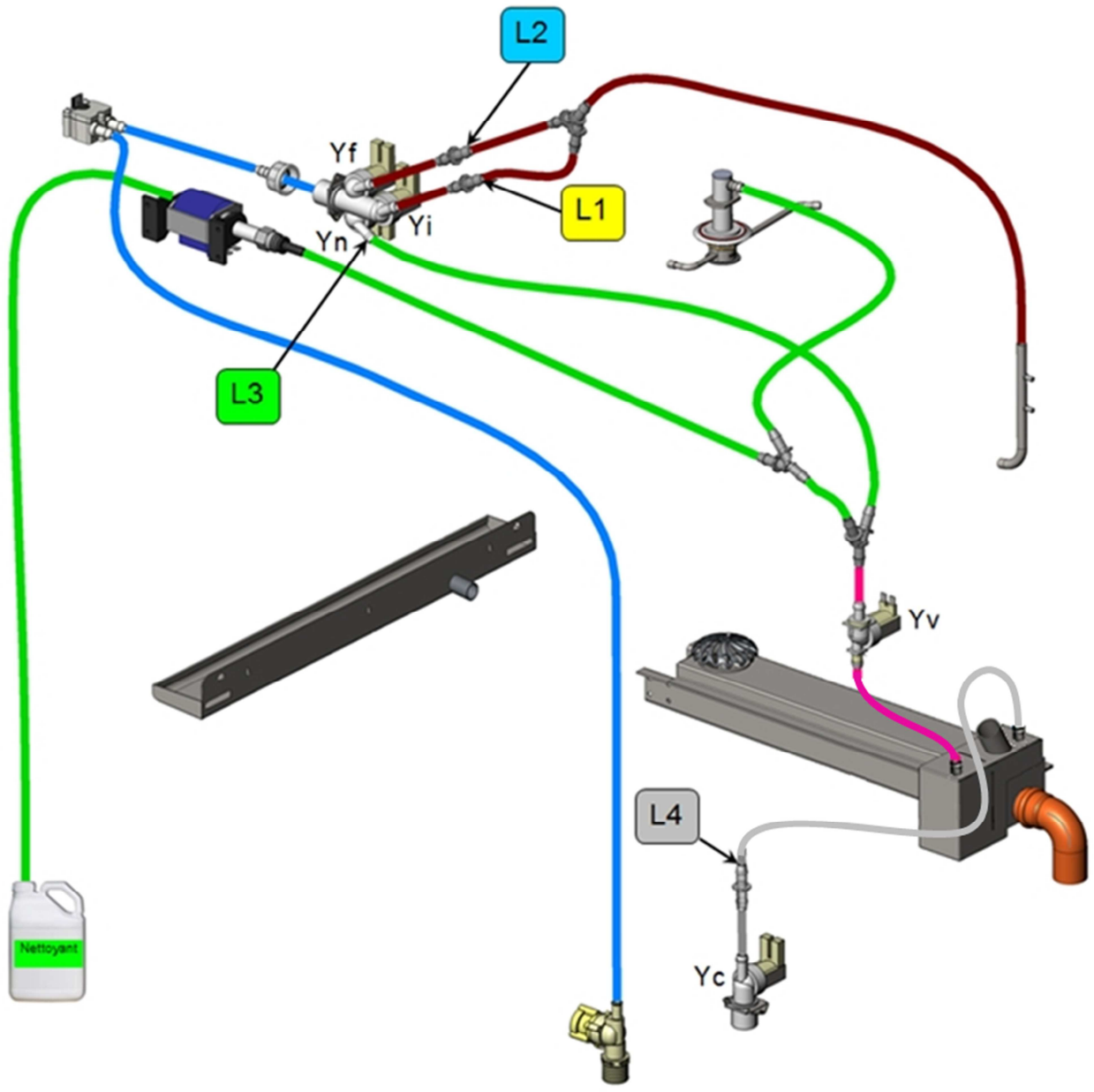

Flow restrictors			
Injection	Cooling	Cleaning	Drain
L1	L2	L3	L4
0.25 l/min	0.5 l/min	5 l/min	0.8 l/min



VULCAN
 A division of ITW Food Equipment Group LLC
 P.O. Box 696
 Louisville, KY 40201

7 PREVENTIVE MAINTENANCE

To ensure the proper, long-lasting and safe functioning of the equipment, it should be serviced by qualified personnel from our company.

The customer will be automatically informed when service is needed. The service counter is a calculated function of the frequency of use and of the number of hours between 2 services.

These values must be entered by the technician when installing the oven and must be verified after every maintenance operation.

7.1 LIST OF ACTIONS

Subject	Recommendations (Every year Or every 3000 h)
General	
Earthing	Check earth continuity
Levelling	Levelling - Height of the loading threshold
Facia / Screen	
Control facia seal	No trace of water leakage or humidity inside the control facia and on electronic card protections; Replace the control facia seal if necessary
Electronics screen	No dirt or dust deposit on components
screen connections	No oxidation on USB / RJ45 plug terminals
Coder	No trace of water leakage or oxidation - Check correct operation
Technical compartment	
Ventilation openings / Technical fan	Cleaning the openings - Cleaning the fan blades
Supply terminals	No trace of overheating - Tighten connections
Fuse-holders (if any)	No trace of overheating - Tighten connections
Contactors	No trace of overheating - Tighten connections
Power assembly card	General dusting - No oxidation on outlet contacts - Check Fuse condition (Visual inspection of LEDs status)
Vent	General sealing - Check gasket - Cleaning - Operation
Heating	
Ventilation Motor	Systematic replacement of drive shaft gasket - Check tightness of fixings - Lubrication of shaft (High temperature lubricant)
Direction of rotation	Check that the motor changes direction of rotation every 4 min in convection mode
Heating elements	No trace of overheating on connections - Tightening electric connections - Measurement of intensities
Hydraulics	
General sealing	Visual inspection
Water inlet	Cleaning of the filter
Flow sensor	No trace of leakage - No oxidation on electrical harness contacts - If necessary, thighten the hydraulic clamps and clean the electrical contacts.
Solenoid valves	No indication of overheating on coils (Possible colour change) - Check its operation
Cleaning product circuit	Check the condition of the different components: container base valve, Pump fitting - Pump - Cleaning of the container base valve - Replace the product suction PVC hose and other components if necessary.
Cavity	
General condition	No rust stain - Cleaning efficiency - Descaling
Seal	Cleaning - General condition - Replacement if necessary
Core probe	General condition (tip, cable) - Check the tightness of the bulkhead grip and its seal
Sprinkler / Wash arm	Operation; free rotation of the arm ; cleaning the nozzles; mechanical fixation
Water injection nozzle	Internal cleaning - Possible descaling - Replacement of the gasket - Mechanical fixation
Drain	Cleanliness - Fixation of grid - Sealing ; Replace the seal if necessary
Collection channel under door	Sealing - Cleanliness of the drain
Cavity drain valve (If any)	Good operation - Internal sealing
Door	
Top and bottom hinges	Check general condition (Wear...); Lubrication
Inner door	Condition and presence of inner door stops (Complete if necessary); Check good rotation and efficiency of locking spring (Adjust if necessary)
Lighting strip label	Check condition of the label (it must ensure water tightness) - Cleaning - Replace if necessary
Door closing mechanism	Check gaps and general fastening - Wear status of parts subject to friction

Caution: The appliance must be isolated electrically during cleaning or maintenance and when replacing parts.



VULCAN

A division of ITW Food Equipment Group LLC

P.O. Box 696

Louisville, KY 40201

7.2 WORKING ON THE DETERGENT PUMPS



- ◆ Danger of eye and skin irritation or acid burns.
Detergents will cause irritation and possible burns if in direct contact with the skin or eyes.
 - Do not inhale the mist or spray
 - Avoid direct contact with these products
 - Never open the oven door during the automatic cleaning cycle
 - Wear protective clothing, gloves and hermetic protective goggles in accordance with the safety data sheet.
- ◆ Remember the dangers identified on the safety data sheet for each detergent
 - Harmful if swallowed.
 - Can result in serious burns.
 - Irritates the eyes.
 - Irritates the respiratory tracts.
 - Risk of serious eye lesions.
- ◆ Remember the safety advice provided by the safety data sheet for each detergent
 - Do not eat or drink when using these products.
 - Do not inhale their vapours.
 - If case of contact with eyes rinse immediately with plenty of water and seek medical advice.
 - Wear appropriate protective clothing, gloves and face and eye protective gear.
 - In the event of an accident or sickness seek immediate medical attention
 - Dispose of the product and its container as hazardous waste.

Procedure

Isolate the electrical supply to the oven
Squeeze the entry and exit hoses using cable ties

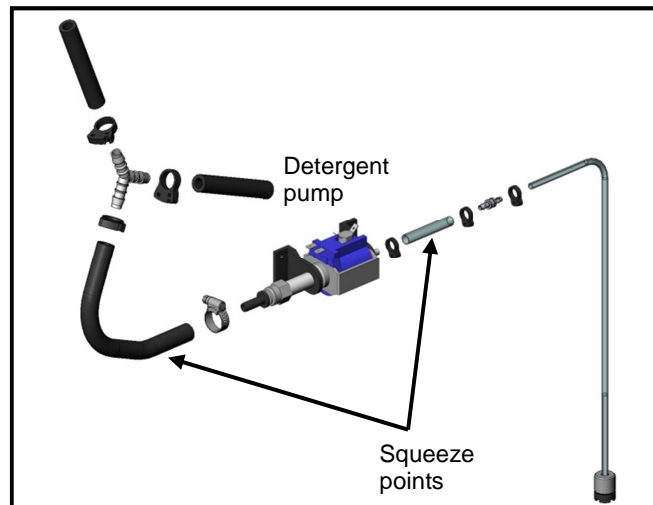

Disconnect the hoses
Replace the pump

8 PROCEDURE FOR CHANGING COMPONENTS

8.1 LOCATION OF TECHNICAL COMPONENTS

Caution: The appliance must be isolated electrically during cleaning or maintenance and when replacing parts.

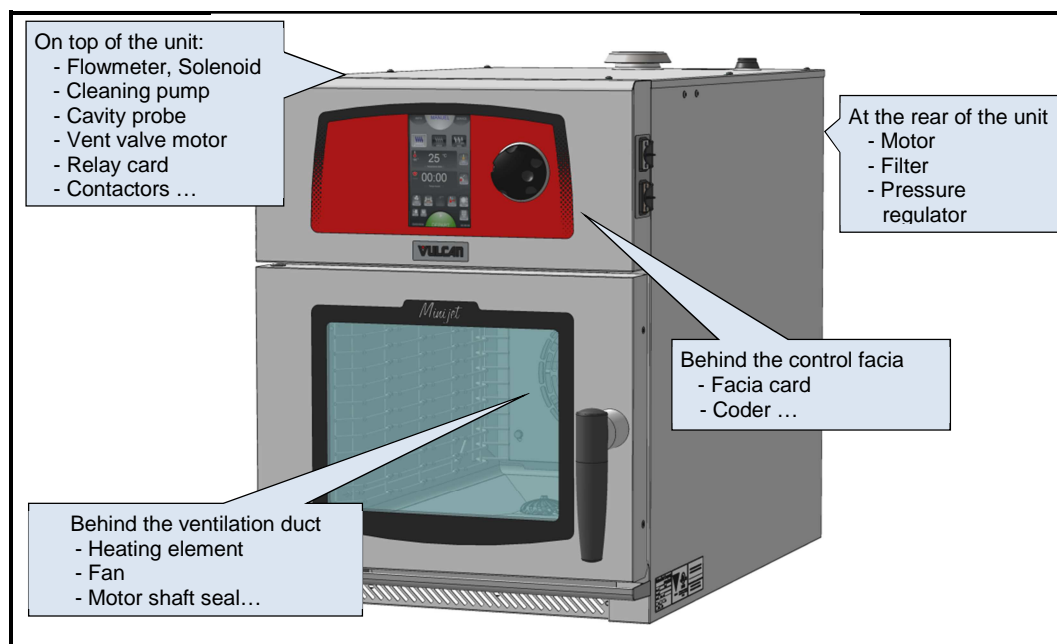

8.2 ACCESS TO COMPONENTS

8.2.1 ON TOP OF THE OVEN

- Unscrew the vent outlet cover
- Undo the 6 PH2 Phillips screws with their plastic washers to release the top.
- Remove the top plate



8.2.2 BEHIND THE CONTROL FACIA

- Open the top of the oven
 - See the section on access to components «On top of the oven»
- Opening the control facia panel
 - Open the oven door
 - Unscrew the 3 PH2 Phillips screws under the control facia
 - Undo, from above, the 2 M4 setscrews with washers on each side of the facia.
- Removing the facia
 - Lift slightly and pull it towards you
 - Disconnect the RJ45 cable between the relay and screen cards
 - Disconnect the core probe socket from the terminals on the relay card

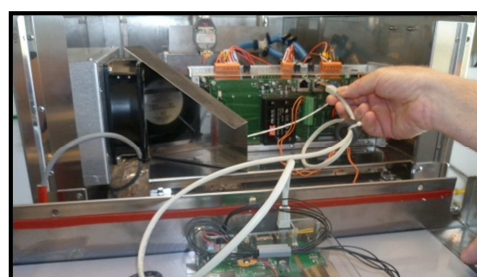
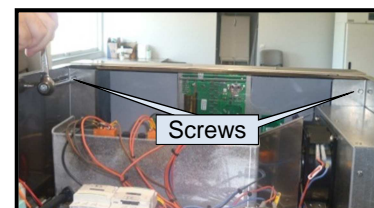

Place the control facia on a clean smooth surface so as to avoid scratching the screen



VULCAN

A division of ITW Food Equipment Group LLC
P.O. Box 696
Louisville, KY 40201

8.2.3 BEHIND THE OVEN

- Undo the two M4 screws with washers at the base of the back plate
- Undo the 2 PH2 Phillips screws at the top of the back plate
- Remove the plate by pulling it gently downwards then towards you

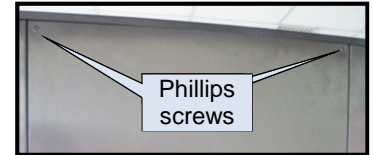
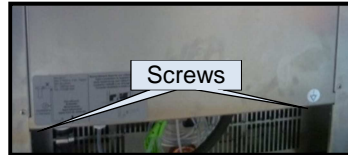

8.3 CODER

- Open the top of the oven
 - See the section on access to components «On top of the oven»
- Removing the facia
 - See the section on access to components «Behind the control facia»
- Remove the coder knob
- Undo the code fixing nut (12mm spanner)
- Turn the facia over
 - Place the control facia on a clean smooth surface so as to avoid scratching the screen*
- Disconnect the coder from the screen card
- Remove the coder and change it

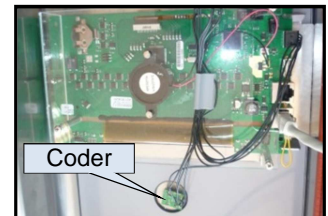

8.4 SCREEN CARD

- Removing the facia
 - See the section on access to components «Behind the control facia»
- Disconnect the screen card:
 - The cable from USB port if the oven has one
 - The coder
 - Disconnect the RJ45 cable
- Removing the screen card
 - Undo the blind nut (thin 5.5mm spanner)
 - Remove the spring
 - Tilt the card towards you and lift it out of its notches
- Change the screen card

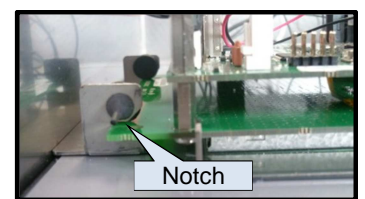
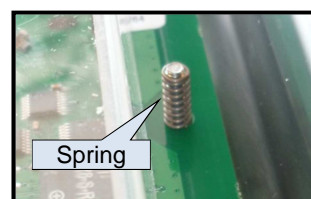
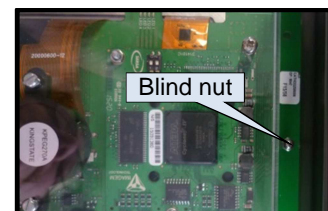
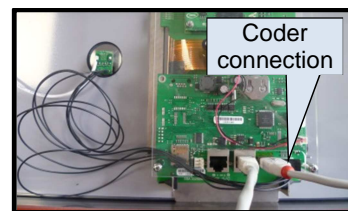

8.4.1 BUZZER ON THE SCREEN CARD

- Disconnect the Buzzer from the screen card
- Removing the buzzer
 - Undo the 3 screws holding the cover
 - Lift the cover off
 - Undo the two screws holding the buzzer
- Change the buzzer
 - When refitting the buzzer to the cover it will function best if you do not tighten the fixing screws too much.*
 - The buzzer can be left "floating"*

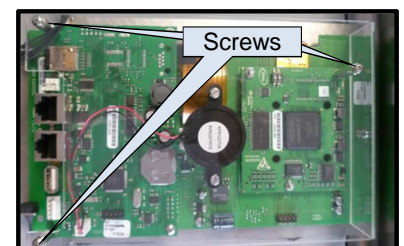

8.5 RELAY CARD (complete assembly with box)

To access the Motor fuses, ... except triac, solenoid, the relay card does not need to be removed.

- Access to relay card(s)
 - Open the top of the oven
 - ◆ See the section on access to components «On top of the oven»
- Removing the failed relay card box
 - Disconnect from the card
 - ◆ The 3 output connectors
 - ◆ Probe connector
 - ◆ The flow meter connector
 - ◆ The core probe connector (green on the right)
 - ◆ The RJ45 socket
 - ◆ Supply connector
 - ◆ The door switch connector
 - Gently undo the 4mm screws from each side of the relay card box
 - Push the box and card assembly to the right then pull it upward

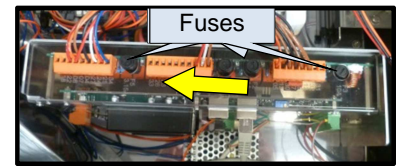
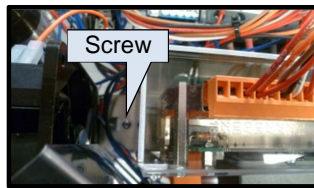
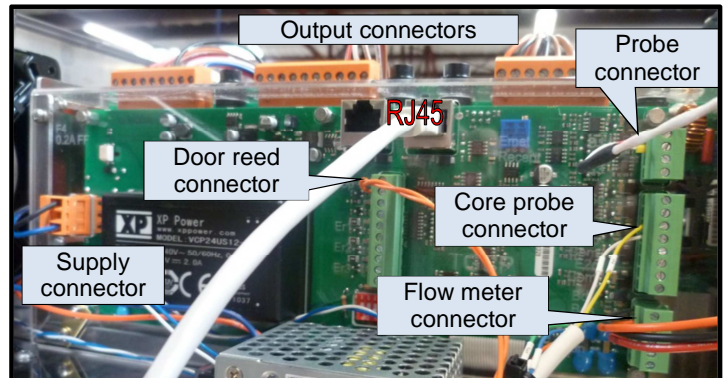

8.5.1 OUTPUT CONTROL CARD

- To remove the complete relay card box
 - See section on «Relay card»
- Undo the 4 cross head screws holding the clear protective cover on the box
- Remove the cards from the metal support
- Place the box on a table (transparent face down)
- Removing the card:
 - Undo the 4 screws holding the card onto the stubs.
 - Disconnect the ribbon cable between the output control card and the main card
 - Place the card nearby
- Change the card

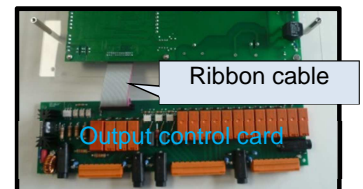
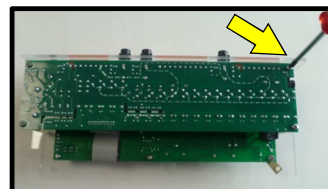

8.5.2 MAIN CARD

- Remove the output control card
 - See section on relay card in «Output control card»
- Removing the Main card:
 - Undo the 6 screw nuts holding the card to the transparent box (5.5mm spanner)
- Change the Main card

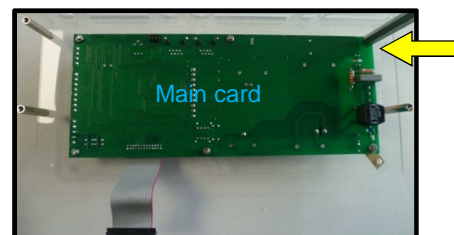

8.6 LED STRIP (IN THE DOOR)

- Open the door
- To open the internal glass
 - Press gently on the retaining clips to release the glass
- Removing the door panelling
 - Undo the 2 Phillips screws on the side of the door
 - Undo the 5 Phillips screws holding the door panelling
 - Remove the panelling and the 2 internal glass retaining clips
- To remove the LED strip
 - Undo the 2 screws holding the strip
 - Be careful not to lose the 2 plastic spacer located behind the lighting strip*
 - Remove the lighting strip
 - Disconnect the supply cable using a terminal screwdriver
- Change the LED lighting strip
 - When refitting do not forget the two plastic spacers that go behind the LED strip*

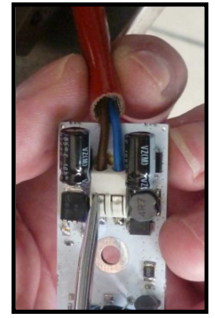

8.7 CLOSING MECHANISM

- Open the door
- To open the internal glass
 - Press gently on the retaining clips to release the glass
- Removing the door panelling
 - Undo the 2 PH2 Phillips screws on the side of the door
 - Undo the 5 PH2 Phillips screws holding the door panelling
 - Remove the panelling and the 2 internal glass retaining clips
- Removing the door handle
 - Undo the 3 M4 Allen screws holding the handle to the door
 - Remove the handle
- Removing the closing mechanism
 - Undo the central handle mechanism fixing screw
 - Withdraw the mechanism
- Change the closing mechanism
 - When refitting the mechanism put a medium bead of thread lock on the screw*

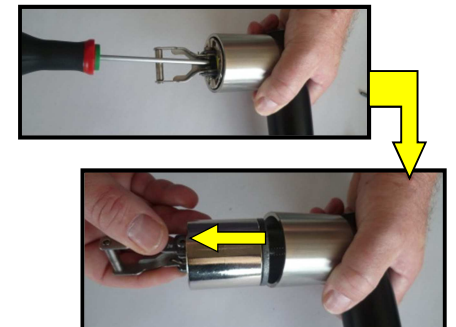

8.8 INTERNAL GLASS

- Open the door
- To open the internal glass
 - Press gently on the retaining clips to release the glass
- Removing the glass
 - Lift the glass to release it from its brackets
 - Be careful not to lose the two brass spacers*

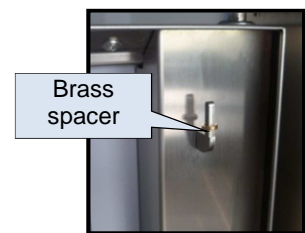

8.9 DOOR CATCH

- Open the door
- Undo the 2 M6 PZ3 Pozidriv screws
- Remove the catch and its 2 packing shims
- Change the catch
When refitting ensure the shims are the right way round



8.10 DOOR

- Open the door
- Open the top of the oven
 - See the section on access to components «On top of the oven»
- Removing the fascia
 - See the section on access to components «Behind the control fascia»
- Remove the internal glass
 - See section on «Internal glass»
- Undo the M4 x 12mm setscrew and remove it and its washer
- Disconnecting the LED lighting strip
 - Cut the tie wrap(s) holding the LED's supply cable to the technical fan
 - Disconnect the cable from the lighting transformer
 - Remove the cable from the top of the oven
- Removing the door
 - Lift the upper hinge assembly to release the door axis whilst holding the door
 - Remove the door
- Change the door
When refitting, recover the two brass spacers from the internal glass of the old door

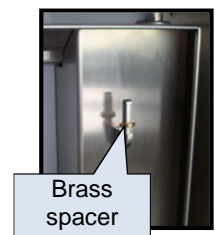
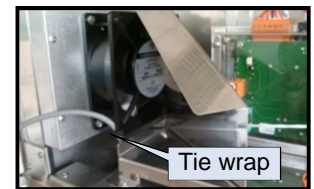
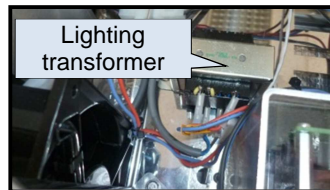

8.11 VENT VALVE MOTOR

- Open the top of the oven
 - See the section on access to components «On top of the oven»
- Disconnect the electrical supply to the motor
- To remove the motor
 - Slacken the bolt connecting the short shaft to the motor several turns
It is advisable not to remove the bolt without supporting the short shaft
 - Undo the 2 nuts holding the motor to its support
 - Remove the motor
- Change the motor
When refitting remember to retighten the connecting bolt between the short shaft and the motor

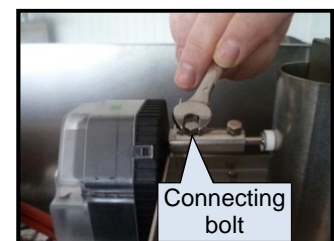

8.12 FLOW METER

- Open the top of the oven
 - See the section on access to components «On top of the oven»
- Disconnect the electrical supply to the flow meter
- To remove the flow meter + support
 - Undo the bolt holding the support
- Open the top of the oven
 - See the section on access to components «On top of the oven»
- Disconnect the electrical supply to the flow meter
- To remove the flow meter + support
 - Undo the bolt holding the support
- Open the top of the oven

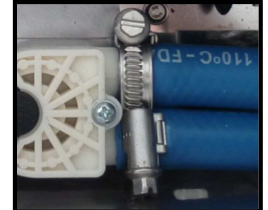
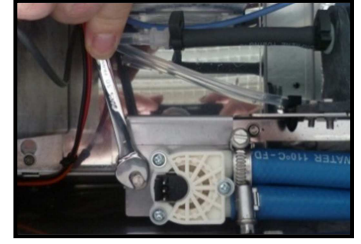
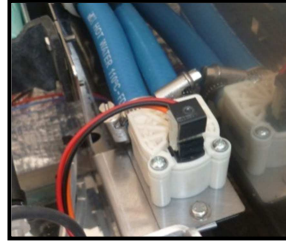

8.13 TEMPERATURE PROBE

- Open the top of the oven
 - See the section on access to components «On top of the oven»
- To disconnect the probe electrically
 - Unclip the terminal block from the card
 - Disconnect the two wires from the terminal
- To remove the probe
 - Remove the holding clip
 - Remove the probe and its seal
- Change the probe and seal

The probe seal must always be changed if the probe is changed or removed for any reason

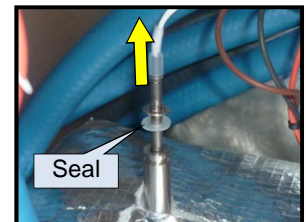
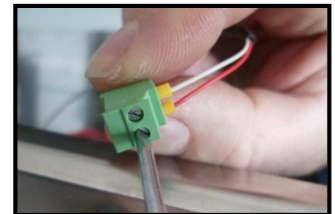
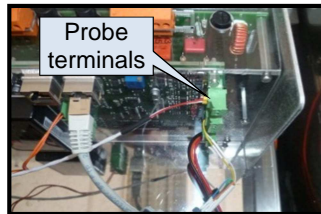

8.14 CLEANING PRODUCT PUMP

- Open the top of the oven
 - See the section on access to components «On top of the oven»
- Disconnect electrically
 - Disconnect the electrical supply to the pump
- Disconnect hydraulically
 - Cut the clamps holding the hoses
 - Pull the entry and exit hose off the pump
- To remove the pump
 - Undo the 4 M4 bolts
 - Remove the pump

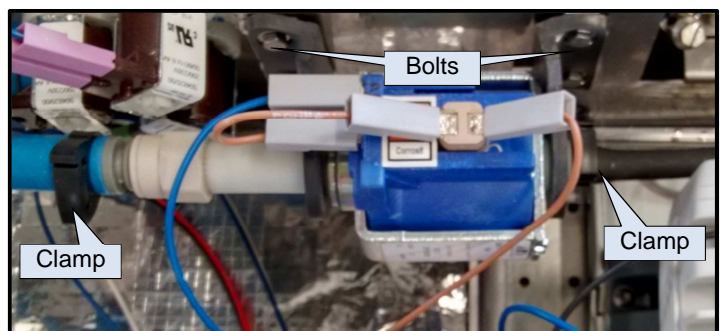

8.15 HEATING ELEMENT

- Open the oven door
- Remove the oven runners
- To remove the ventilation duct
 - Undo the 4 fixing screws
 - Remove the duct

Put some protective cardboard in the base of the oven in case the element or any tools are dropped during this operation

- Undo the blind nut holding the bottom and the 3 M6 bolts holding the top
- Pull the element gently towards you
- Disconnect the element using two open ended spanners
- Remove the element
- Change the element and its seal, then reconnect the new element exactly as the old one

We recommend that the seal be replaced systematically when an element is changed and at each annual service

Note: If you have access to the rear of the oven it is possible to disconnect the element from the rear. After undoing the 4 fixings holding the element inside the oven cavity:

- Open the rear of the oven: See section on access to components «Behind the oven»
- Remove the clip holding the plastic protective film and remove the film
- Disconnect the wiring to the element

When refitting do not forget to fit the protective film

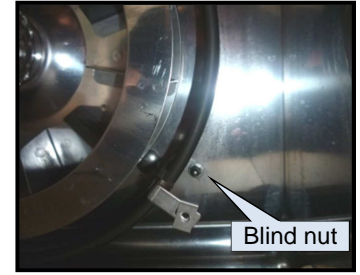
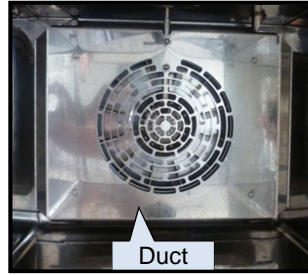

Element electrical connections seen from the rear of the oven



8.15.1 ELEMENT SEAL

- Open the oven door
- Removing the element
 - See section on «Element»
- Remove the seal and change it

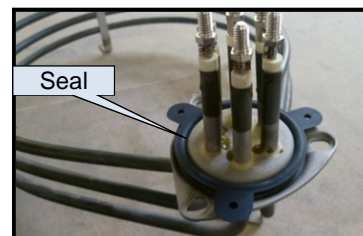

8.16 FAN

- Open the oven door
- Remove the runners
- To remove the ventilation duct
 - Undo the 4 fixing screws
 - Remove the duct

Put some protective cardboard in the base of the oven in case the fan or any tools are dropped during this operation

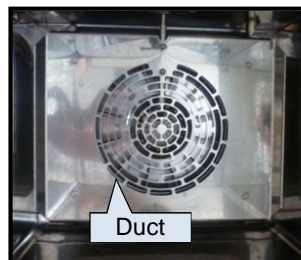

- Undo the bolt holding the injection diffuser ring
- Remove this together with the flat washer
- Refit the fixing bolt to avoid any damage to the motor shaft thread
- Fit a medium sized puller
- With one hand support the fan whilst turning the puller nut with a suitable spanner until the fan is free
- Remove the puller together with the fan
- Change the fan

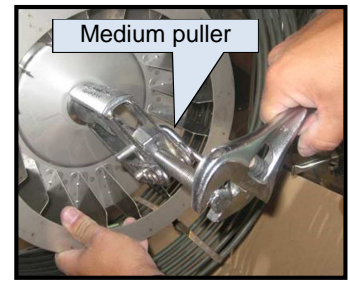

8.17 MOTOR SEAL

- Remove the element
 - See section on «Element»
- Remove the motor shaft seal and its wear ring

When replacing a motor seal always remember to change the wear ring
- Lubricate the motor shaft with high temperature food quality grease such as BIOLUB

When refitting: Fit the assembly onto the motor shaft and rotate the shaft before fitting the fan, to ensure the seal and wear ring are correctly located (they should not rotate with the shaft)



8.18 MOTOR

- Remove the fan
 - See section on «Fan»
- Remove the motor shaft seal and its wear ring
 - See section on «Motor shaft seal»

Systematically replace the seal and wear ring when changing a motor
- Open the rear of the oven:
 - See section on access to components «Behind the oven»
- Undo the screws fixing the electrical connection cover and swing it to the right
- Open the top of the oven
 - See section on access to components «On top of the oven»
- Disconnect the motor electrically
- To remove the motor
 - Undo the 4 brass nuts and washers holding the motor.
 - Remove the motor by pulling it gently downwards then towards you

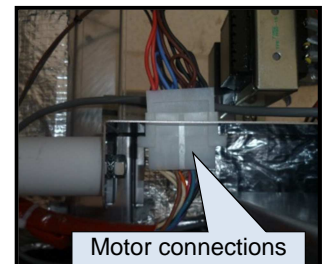

8.19 CAVITY SEAL

- Open the door
- Pinch the seal in one of the corners and pull it towards you
- Unclip the seal all the way round and pull it off
- Change the seal

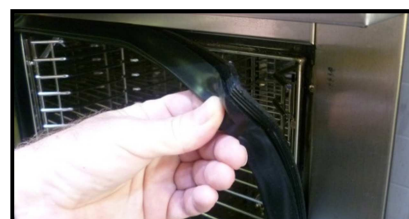

9 CHECKING THE TEMPERATURE SENSORS

9.1 PT100 PROBE

PT100 probe components

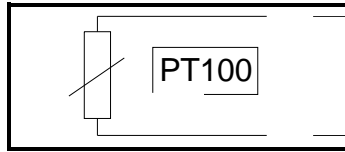

Temperature sensor comprises a resistance sensor with the value of 100 ohms for a temperature of 32°F and 138.5 ohms for a temperature of 212°F. The variation of the resistance to temperature relationship is linear. The resistance reading is directly proportional to the measured temperature. The sensor is not polarised. The sensor can be extended using copper wire.

Temperature in °F relative to Resistance in Ω for PT100 sensor										
°F	0	1	2	3	4	5	6	7	8	9
30			100.00	100.22	100.43	100.65	100.87	101.08	101.30	101.52
40	101.73	101.95	102.17	102.39	102.60	102.82	103.04	103.25	103.47	103.69
50	103.90	104.12	104.33	104.55	104.77	104.98	105.20	105.42	105.63	105.85
60	106.06	106.28	106.50	106.71	106.93	107.14	107.36	107.58	107.79	108.01
70	108.22	108.44	108.66	108.87	109.09	109.30	109.52	109.73	109.95	110.16
80	110.38	110.60	110.81	111.03	111.24	111.46	111.67	111.89	112.10	112.32
90	112.53	112.75	112.96	113.18	113.39	113.61	113.82	114.04	114.25	114.47
100	114.68	114.90	115.11	115.33	115.54	115.75	115.97	116.18	116.40	116.61
110	116.83	117.04	117.26	117.47	117.68	117.90	118.11	118.33	118.54	118.75
120	118.97	119.18	119.40	119.61	119.82	120.04	120.25	120.47	120.68	120.89
130	121.11	121.32	121.53	121.75	121.96	122.17	122.39	122.60	122.81	123.03
140	123.24	123.45	123.67	123.88	124.09	124.31	124.52	124.73	124.94	125.16
150	125.37	125.58	125.80	126.01	126.22	126.44	126.65	126.86	127.07	127.29
160	127.50	127.71	127.92	128.14	128.35	128.56	128.77	128.99	129.20	129.41
170	129.62	129.84	130.05	130.26	130.47	130.68	130.90	131.11	131.32	131.53
180	131.74	131.96	132.17	132.38	132.59	132.80	133.01	133.23	133.44	133.65
190	133.86	134.07	134.28	134.49	134.71	134.92	135.13	135.34	135.55	135.76
200	135.97	136.18	136.40	136.61	136.82	137.03	137.24	137.45	137.66	137.87
210	138.08	138.29	138.50	138.72	138.93	139.14	139.35	139.56	139.77	139.98
220	140.19	140.40	140.61	140.82	141.03	141.24	141.45	141.66	141.87	142.08
230	142.29	142.50	142.71	142.92	143.13	143.34	143.55	143.76	143.97	144.18
240	144.39	144.60	144.81	145.02	145.23	145.44	145.65	145.86	146.07	146.28
250	146.49	146.70	146.90	147.11	147.32	147.53	147.74	147.95	148.16	148.37
260	148.58	148.79	149.00	149.20	149.41	149.62	149.83	150.04	150.25	150.46
270	150.67	150.87	151.08	151.29	151.50	151.71	151.92	152.13	152.33	152.54
280	152.75	152.96	153.17	153.38	153.58	153.79	154.00	154.21	154.42	154.62
290	154.83	155.04	155.25	155.46	155.66	155.87	156.08	156.29	156.49	156.70
300	156.91	157.12	157.32	157.53	157.74	157.95	158.15	158.36	158.57	158.78
310	158.98	159.19	159.40	159.60	159.81	160.02	160.23	160.43	160.64	160.85
320	161.05	161.26	161.47	161.67	161.88	162.09	162.29	162.50	162.71	162.91
330	163.12	163.33	163.53	163.74	163.95	164.15	164.36	164.56	164.77	164.98
340	165.18	165.39	165.60	165.80	166.01	166.21	166.42	166.63	166.83	167.04
350	167.24	167.45	167.65	167.86	168.07	168.27	168.48	168.68	168.89	169.09
360	169.30	169.50	169.71	169.92	170.12	170.33	170.53	170.74	170.94	171.15
370	171.35	171.56	171.76	171.97	172.17	172.38	172.58	172.79	172.99	173.20
380	173.40	173.61	173.81	174.01	174.22	174.42	174.63	174.83	175.04	175.24
390	175.45	175.65	175.86	176.06	176.26	176.47	176.67	176.88	177.08	177.28
400	177.49	177.69	177.90	178.10	178.30	178.51	178.71	178.92	179.12	179.32
410	179.53	179.73	179.93	180.14	180.34	180.54	180.75	180.95	181.15	181.36
420	181.56	181.76	181.97	182.17	182.37	182.58	182.78	182.98	183.19	183.39
430	183.59	183.80	184.00	184.20	184.41	184.61	184.81	185.01	185.21	185.42
440	185.62	185.82	186.03	186.23	186.43	186.63	186.83	187.04	187.24	187.44



How to read the chart:

To find the resistance corresponding to a temperature of 235°F.

- Find the intersection of the line 230°F and the column 5°F.
- The reading shows 143.34 Ohms.

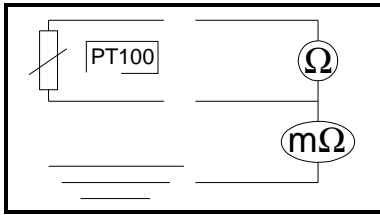
Check

Check sensor resistance with an ohmmeter set to 200 ohms (less than 107 ohms for 20°).

Check the sensor insulation between one of the leads and the metal part with the ohmmeter set at 20 mega ohms (a value over 15 mega ohms).

Check the continuity between the feed and the metal part of the sensor.

10 FRONT LINE PARTS

Designation	Codes
Drive shaft gasket + wear ring	145587
3 way solenoid valve, 2 x 10 L/min + 1 x 5 L/min	148648
1 way solenoid valve, 1 x 10 L/min	148647
Heating element after sales kit	166754
Reed switch	300676
Three-pole 25A 230V 50/60 Hz contactor	300698
Anti-interference relay filter	300769
Ultra fast fuse 0.2A 250V 5 x 20	300787
Fuse 5 x 20 10 Amps	300788
Safety thermostat	301066
1 point regulation probe, PT 100	301485
Axial fan	304297
Motor	304295
Capacitor 12.5µf	304296
Reducing gear with centre return spring, 85 degrees	305110
Lighting transformer BT 230V 50HZ 12V	308350
1A Temporized fuse	300789
Fuse 2 Amps	300790
Fuse 0.25 Amps temporized	300791
Fuse 3.15 Amps	309407
Fuse 10 Amps 10.3*38.1 class cc	300793
Transformer	308491
Transformer 230V/24V	308492
FASTPAD screen card	309634
LED strip	309638
Coder	309644
Output control card	309663
Inlet/outlet 1 way solenoid valve, 10 L/min	314380
Pump kit	314379
Flow meter FHKC56	314374
Heating element + immersion heater gasket	366461
Door stop	366572
Door closure mechanism	384183
Door catch sub assembly	384677



VULCAN

A division of ITW Food Equipment Group LLC

P.O. Box 696

Louisville, KY 40201