

VULCAN

CATALOG OF REPLACEMENT PARTS

85MF PORTABLE FILTER

<i>MODEL</i>	<i>ML NUMBER</i>
<i>85MF</i>	<i>ML-136405</i>



For additional information on Vulcan-Hart Company or to locate an authorized parts and service provider in your area, visit our website at www.vulcanhart.com

Table of Contents

3	PAPERLESS FILTER
5	FILTER VESSEL
7	MOTOR AND PIPING

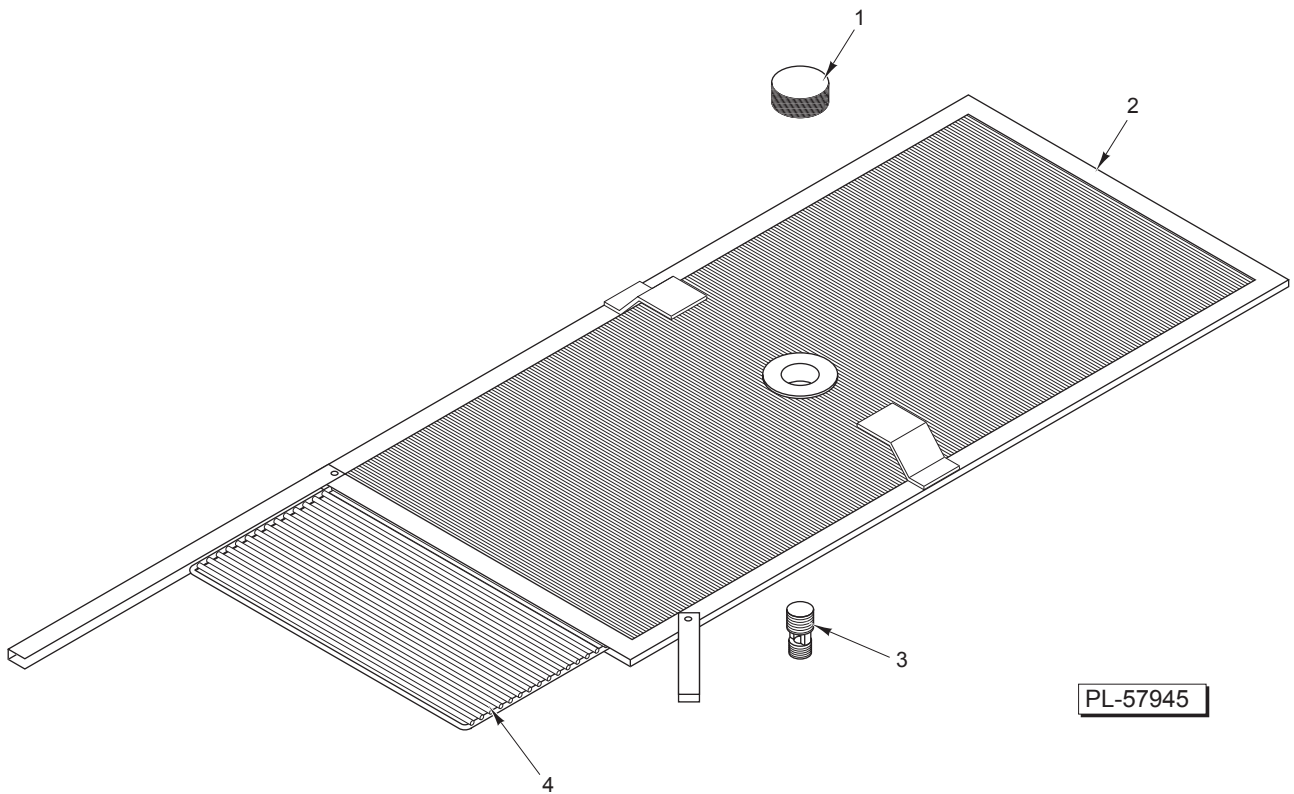

PAPERLESS FILTER

ILLUS.	PART NO.	NAME OF PART	AMT.
PL-57945			
1	00-422554-00001	Knob – Knurl	1
2	00-422545-00003	Filter Element	1
3	00-422467-00001	Pipe – Suction	1
4	00-422552-00003	Insert	1

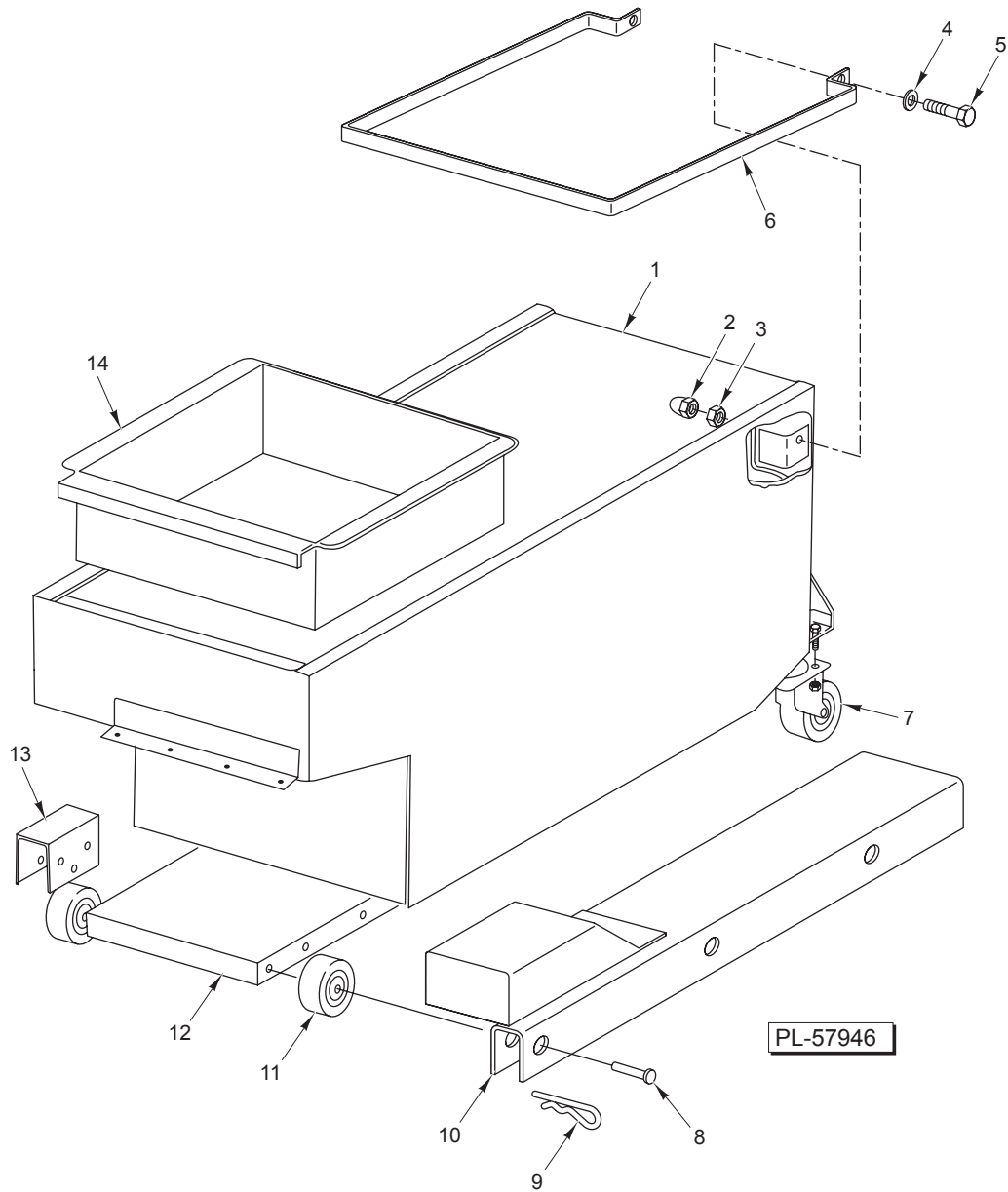

FILTER VESSEL

FILTER VESSEL

ILLUS.	PART NO.	NAME OF PART	AMT.
PL-57946			
1	00-419490-000G2	Vessel Assy.	1
2	NS-025-06	Castle Nut 1/4-20 (SST)	2
3	NS-041-04	Lock Nut 1/4-20 Eslok (SST)	2
4	WS-004-33	Washer	4
5	SC-116-19	Shoulder Bolt 1/4-20 x 3/4	2
6	00-419493-000G2	Handle – Vessel Assy.	1
7	00-415342-00001	Caster – Swivel (Rear)	2
8	00-403971-00002	Pin – Axle	2
9	00-417850-00001	Clip – Hitch Pin	2
10	00-418076-000G1	Bracket (RH)	1
11	00-415342-00002	Wheel (Front)	2
12	00-417769-00001	Base – Pump	1
13	00-417788-00001	Bracket (LH)	1
14	00-418598-000G1	Pan – Crumb Screen Assy.	1

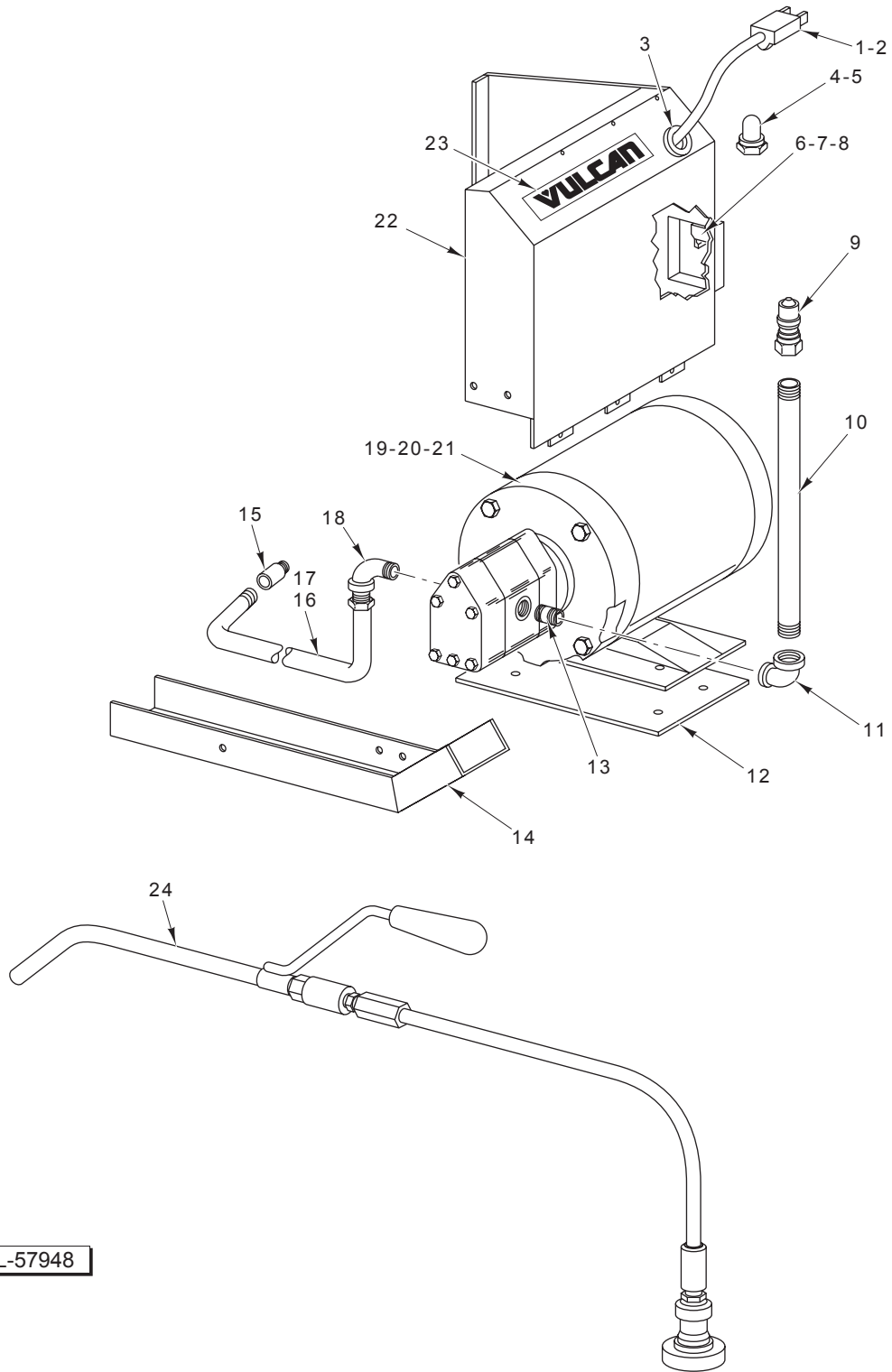

PL-57948

MOTOR AND PIPING

MOTOR AND PIPING

ILLUS.	PART NO.	NAME OF PART	AMT.
PL-57948			
1	00-418956-000G3	Power Cord (115 V.)	1
2	00-418956-000G4	Power Cord (200-240 V.)	1
3	FE-024-25	Strain Relief	1
4	00-417932-00001	Boot (120 V.)	1
5	00-424423-00002	Boot (208-240 V.)	1
6	00-411496-000A8	Switch – Toggle (Double Pole W/Center Off) (120 V.)	1
7	00-424423-00001	Switch – Toggle (208-240 V.)	1
8	00-414270-00002	Insulator – Switch (Fish Paper)	1
9	00-418781-00001	Valve – Quick Disconnect	1
10	FP-089-66	Pipe 1/2 x 8 In.	1
11	FP-077-68	Elbow 1/2 90 Deg.	1
12	00-417920-00001	Gasket – Hose	1
13	FP-035-91	Pipe Nipple 1/2 x 1.25	1
14	00-417904-00002	Plate – Skid	1
15	FP-086-89	Fitting Tube Straight	1
16	00-417891-000G1	Heater Assy. (120 V.)	1
17	00-417891-000G2	Heater Assy. (240 V.)	1
18	FP-086-90	Tube 90 Deg.	1
19	00-417792-00001	Pump & Motor Assy. (115 V., 60 Hz.)	1
20	00-417792-00003	Pump & Motor Assy. (208 V., 50/60 Hz.)	1
21	00-417792-00004	Pump & Motor Assy. (230 V., 50/60 Hz.)	1
22	00-417950-000G1	Cover – Motor & Switch (Order Item 8)	1
23	00-421499-00001	Logo – Vulcan	1
24	00-422281-00005	Hose – Tank Wash Assy. (6 Ft.)	1

