



PRECIPAN TILT SKILLET

(Braising Pan – V1)

VPP-28E-208(V1BPT10E-86) 28 gallon, 208 V

VPP-28E-208(V1BPT10E-86) 28 gallon, 208 V

VPP-28E-240 (V1BPT10E-96)28 gallon, 240 V

VPP-28E-480 (V1BPT10E-36)28 gallon, 480 V

VPP-40E-208(V1BPT15E-86) 40 gallon, 208 V

VPP-40E-240 (V1BPT15E-96)40 gallon, 240 V

VPP-40E-480 (V1BPT15E-36)40 gallon, 480 V

- NOTICE -

This Manual is prepared for the use of trained Hobart Service Technicians and should not be used by those not properly qualified.

This manual is not intended to be all encompassing. If you have not attended a Hobart Service School for this product, you should read, in its entirety, the repair procedure you wish to perform to determine if you have the necessary tools, instruments and skills required to perform the procedure. Procedures for which you do not have the necessary tools, instruments and skills should be performed by a trained Hobart Service Technician.

The reproduction, transfer, sale or other use of this manual, without the express written consent of Hobart, is prohibited.

This manual has been provided to you by ITW Food Equipment Group LLC ("ITW FEG") without charge and remains the property of ITW FEG, and by accepting this manual you agree that you will return it to ITW FEG promptly upon its request for such return at any time in the future.

TABLE OF CONTENTS

1. GENERAL	4
SERVICE UPDATES	4
INTRODUCTION	4
INSTALLATION MANUAL	5
OPERATING MANUAL	5
SPECIFICATION SHEETS	5
TOOLS	5
2. REMOVAL AND REPLACEMENT	6
CONTROL PANEL COVER	6
RIGHT SIDE PANEL	6
UTILITY COVER	6
FRONT PANEL	7
LEFT FRONT PANEL	7
LEFT SIDE PANEL	8
CONTROL BOX ACCESS	8
LID SPRINGS	8
TANK RAM MOTOR (VC)	10
3-WAY SOLENOID (YEF, YV, YD)	11
FLOW METER (BD)	12
SINGLE SOLENOID (HOT WATER) (YEC)	12
WATER SUPPLY MANIFOLD (COLD WATER SUPPLY)	13
PRESSURE REGULATOR	13
TOUCHSCREEN FASTPAD 2 (AF)	14
ENCODER KNOB	15
SPEAKER (BUZZER)	15
POWER INPUT AND OUTPUT BOARDS (AR1 & AR2)	16
SWITCHING POWER SUPPLY (TA)	17
SNAP ACTION SWITCHING (SCM & SCD)	17
HINGE COVER	18
BASKET LIFT RAM DETECTION SWITCH (SCU)	18
TRANSFORMER & SWITCHING POWER SUPPLY FUSES (FTCO & FTA)	19
HEATING ELEMENTS (R1, R2, R3)	19
HIGH LIMIT THERMOSTAT (FC1, FC2, FC3)	22
TANK TEMPERATURE BASE PROBES (BF1, BF2, BF3)	23
TANK TEMPERATURE BASE (WELL) PROBE (B SB)	23
3. SERVICE PROCEDURES TEST AND ADJUSTMENTS	25
TANK BACK LEVEL (TEST)	25
TANK BACK LEVEL (ADJUSTMENT)	25
TANK FRONT LEVEL (TEST)	26
TANK FRONT LEVEL (ADJUSTMENT)	27
LID COUNTERBALANCE (TEST)	28
LID COUNTERBALANCE (ADJUSTMENT)	29
HEATING ELEMENT MAINTENANCE - TEST	30
HEATING ELEMENT - TEST	33
4. FIRMWARE / SOFTWARE	35
SOFTWARE CONTROL	35
SOFTWARE VERSIONS	36
SOFTWARE UPDATE PROCEDURE	36
5. PROGRAMMING	39
PARAMETER ACCESS	39
PARAMETERS - COUNTERS	41
MAINTENANCE COUNTER RESET	42
SOFTWARE LANGUAGE SETTING	44

SERIAL NUMBER ACCESS 46
FREQUENCY MAINTENANCE USAGE PER DAY ADJUSTMENT 47

6. ELECTRIC OPERATION 50
 COMPONENT LOCATION & FUNCTION - FASTPAD 2 INPUT BOARD (AR1) 50
 COMPONENT LOCATION & FUNCTION - FASTPAD 2 OUTPUT BOARD (AR2) 51
 COMPONENT LOCATION & FUNCTION - TOUCHSCREEN FASTPAD 2 - WIRE CALLOUTS 53
 COMPONENT LOCATION & FUNCTION - CONTROL BOX 54
 COMPONENT LOCATION & FUNCTION - LOWER PANEL 55
 COMPONENT LOCATION & FUNCTION (VPP-28) 56
 COMPONENT LOCATION & FUNCTION (VPP-40) 59

7. SEQUENCE OF OPERATION 63
 POWER APPLIED 63
 POWER APPLIED, UNIT TURNED ON 63
 DRAINING 64
 BASKET LIFT 64

8. DIAGRAMS 65
 SCHEMATIC / WIRING DIAGRAM 65
 WATER (HYDRAULIC) DIAGRAM 66

9. TROUBLESHOOTING 68
 DIAGNOSTICS 68
 MAINTENANCE / TROUBLESHOOTING SCREENS 69
 ERROR AND INFORMATION CODES 73
 PT100 PROBE CHECK 79
 MOTORIZED LIFT OPTION ONLY 80
 TROUBLESHOOTING 81

1. GENERAL

SERVICE UPDATES

Updated WATER (HYDRAULIC) DIAGRAM.

Updated SCHEMATIC / WIRING DIAGRAM.

December 2024

INTRODUCTION

Vulcan Precision Pan VPP 28 or 40 gallon usable capacity sized units. Multifunction cooking: Simmer, Grill, Braise, Saute, Pan Fry, Steam, and Boil. Large touch screen with visual display of set and actual temperature 80° - 482°F. Auto mode for recipes, reloaded and programmable, up to 5 stages in a cooking cycle. Manual mode with multi-zone temperature controlled cooking and multiple timers. Auto & precise water fill to specific or preset volumes with installation choice for single or dual temperature water control. Embossed gallon and liter markings. Powered touch drain without tilting. Cleaning assist mode with retractable spray hose. Motor driven pan tilt/lift. Auto-lift arm (for use with baskets). Full pour path strainer.

Control Panel	Item	Description
	1	Menu Selection: Auto / Manual / Toolbox
	2	Choice of Mode: Bratt Pan (Plancha) / Boiling Pan
	3	Preheat Before Cooking
	4	Temperature Adjustment: Bath Well Base
	5	Selection Button: Cook Time / Core Temperature
	6	Adjustment Time or Core Temperature
	7	Well Drain
	8	Start Cooking
	9	Multi Zone Heating Menu
	10	Water Fill Menu

Fig. 1

Model Designations

- VPP-28E-208 (V1BPT10E-86) 28 gallon, 208 V
- VPP-28E-240 (V1BPT10E-96) 28 gallon, 240 V
- VPP-28E-480 (V1BPT10E-36) 28 gallon, 480 V
- VPP-40E-208 (V1BPT15E-86) 40 gallon, 208 V
- VPP-40E-240 (V1BPT15E-96) 40 gallon, 240 V
- VPP-40E-480 (V1BPT15E-36) 40 gallon, 480 V

INSTALLATION MANUAL

PRECIPAN V1 INSTALLATION MANUAL

OPERATING MANUAL

PRECIPAN V1 OPERATING MANUAL

SPECIFICATION SHEETS

PRECIPAN V1 SPECIFICATION SHEETS

TOOLS

Standard

- Standard set of hand tools.
- VOM with measuring micro amp current tester. Any VOM with minimum of CAT III 600V, UL/CSA/TUV/ETL certified. Sensitivity of at least 20,000 ohms per volt can be used. Ability to measure uF microfarids. In addition, meter leads must also be a minimum of CAT III 600V.
- Temperature tester (thermocouple type) with surface probe.
- 1 5/8" open end wrench used for removing lid springs and adjusting lid spring tension.
- Field service grounding kit P/N TL-84919.

Special

- Basin Wrench used for removing and installing fill line coupling.
- Torque Wrench used for installing heating elements.

2. REMOVAL AND REPLACEMENT

CONTROL PANEL COVER



WARNING

Disconnect the electrical power to the machine and follow lockout / tagout procedures.

1. Remove screws below front edge.

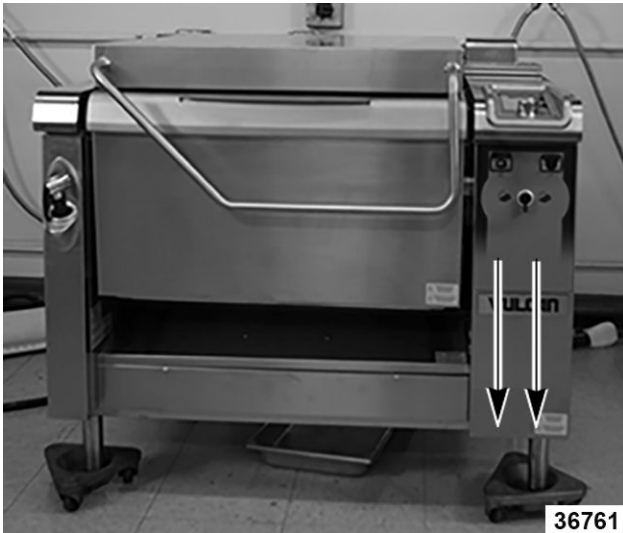

Fig. 2

2. Pull cover down and out from bottom.

NOTE: Verify wires are not disconnected from tilt switch.

3. Reverse procedure to install.
4. Verify proper operation.

NOTE: Right side cover panel must be installed first. To install, align hooks with slots in panel.

RIGHT SIDE PANEL



WARNING

Disconnect the electrical power to the machine and follow lockout / tagout procedures.

1. Remove CONTROL PANEL COVER.
2. Remove screws from bottom of right side panel.

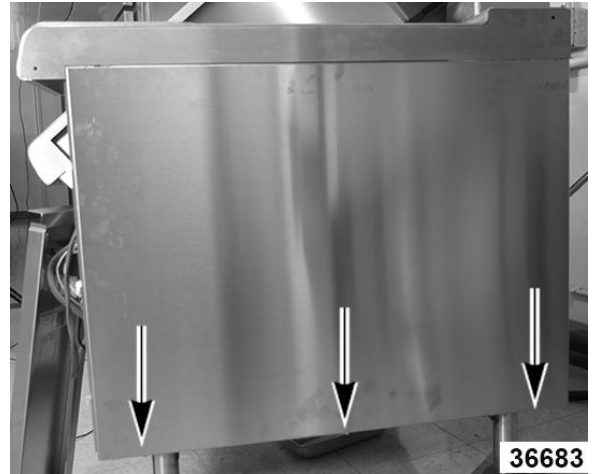

Fig. 3



Fig. 4

3. Reverse procedure to install.
4. Verify proper operation.

UTILITY COVER



WARNING

Disconnect the electrical power to the machine and follow lockout / tagout procedures.

1. Remove screws.



Fig. 5

2. Raise front edge of cover and slide forward.



Fig. 6

3. Reverse procedure to install.
4. Verify proper operation.

FRONT PANEL



WARNING

Disconnect the electrical power to the machine and follow lockout / tagout procedures.

1. Remove screws across top and bottom of panel.



Fig. 7

2. Pull out from bottom of panel.
3. Reverse procedure to install.
4. Verify proper operation.

LEFT FRONT PANEL



WARNING

Disconnect the electrical power to the machine and follow lockout / tagout procedures.

1. Remove screw from cover under front edge.

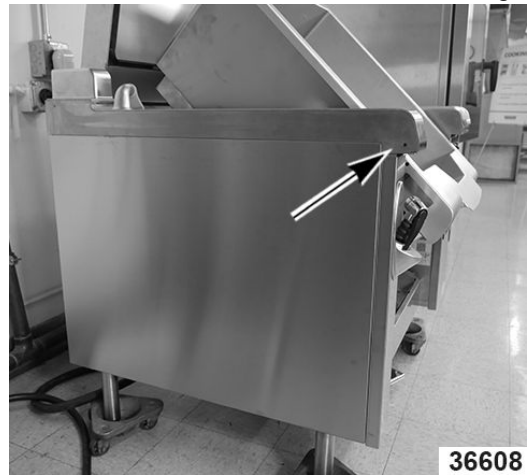

Fig. 8

2. Pull cover down and out from bottom.
3. Reverse procedure to install.
4. Verify proper operation.

NOTE: Left side panel must be installed first. To install, align hooks with slots in panel.



Fig. 9

LEFT SIDE PANEL



WARNING

Disconnect the electrical power to the machine and follow lockout / tagout procedures.

1. Remove LEFT FRONT PANEL.
2. Remove screws from bottom of left side panel.

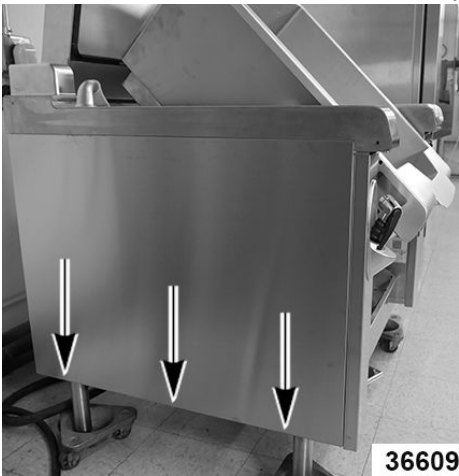

Fig. 10

3. Reverse procedure to install.

CONTROL BOX ACCESS

NOTE: This allows quick access to the input / output boards and fuses.

1. Remove CONTROL PANEL COVER.
2. Slide control box forward.

NOTE: Cables may catch, remove wire ties as needed.



Fig. 11

3. Reverse procedure to install.

NOTE: Reattach any wire ties removed.

NOTE: Verify wires are not being pinched during install.

LID SPRINGS

1. Remove LEFT FRONT PANEL.
2. Remove LEFT SIDE PANEL.
3. Measure from front bracket to spring bracket, 6-5/16", factory default setting.

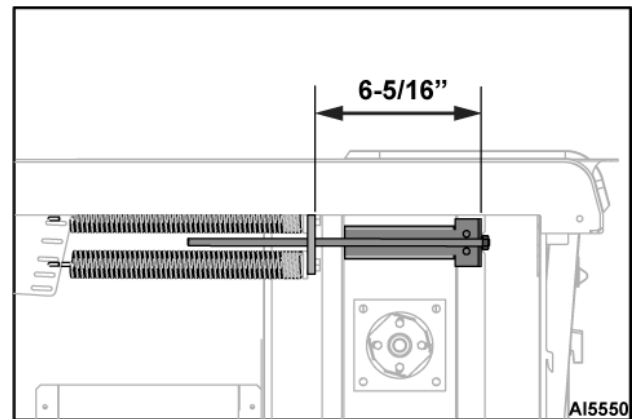

Fig. 12

4. Loosen tension bolt.



Fig. 13

5. Release tension to 3 inches of exposed thread brass bracket.
6. Raise lid.

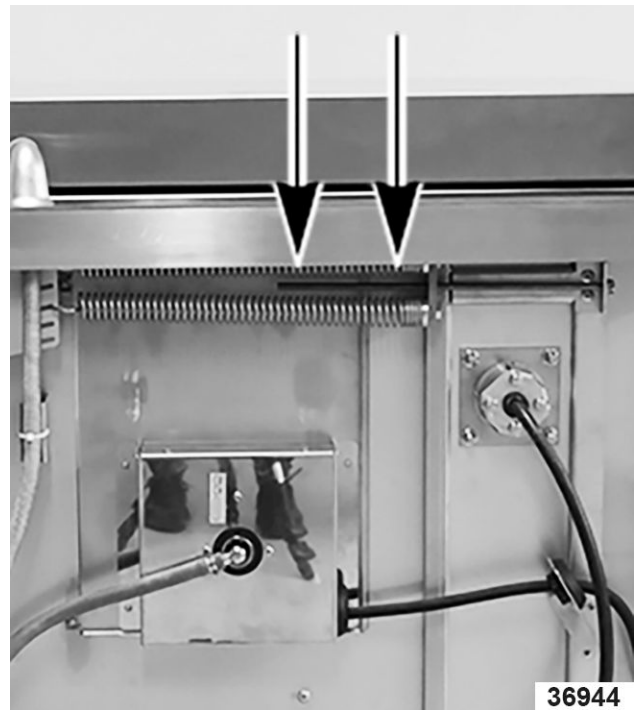

Fig. 14

7. Remove springs from bracket then lower lid.



Fig. 15

8. Loosen bolts and remove springs.



Fig. 16

9. Raise lid, remount springs into position.
10. Close lid and tighten bolt to original measurement.
11. Perform LID COUNTERBALANCE (TEST).
12. Reverse procedure to install.
13. Verify proper operation.

TANK RAM MOTOR (Vc)

1. Remove CONTROL PANEL COVER.
2. Remove RIGHT SIDE PANEL.
3. Loosen tension screw.
4. Document wire locations and disconnect.

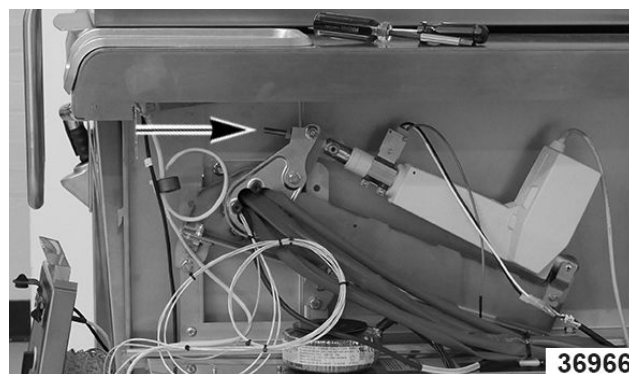

Fig. 17

5. Loosen nut and bolt.

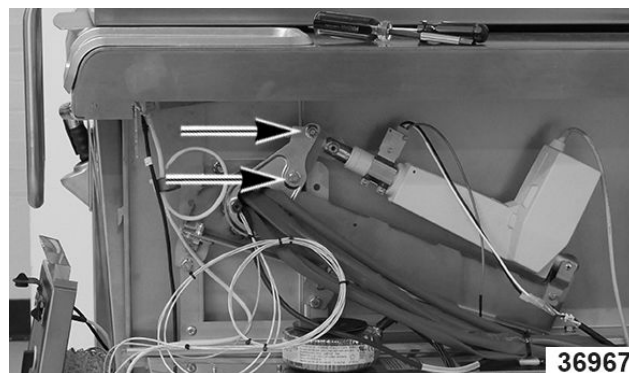

Fig. 18

6. Remove C-clip.



Fig. 19

7. Push pin from back to front to remove.



Fig. 20

8. Remove fixing screw.



Fig. 21

9. Pull pin forward to remove.



Fig. 22

10. Remove tank ram motor.
11. Reverse procedure to install.
12. Reconnect wires.
13. Verify proper operation.

3-WAY SOLENOID (Yef, Yv, Yd)

1. Drain unit.
2. Turn off water supply.



⚠ WARNING

Disconnect the electrical power to the machine and follow lockout / tagout procedures.

3. Remove UTILITY COVER.
4. Remove WATER SUPPLY MANIFOLD (COLD WATER SUPPLY) (2, Fig. 23).

NOTE: Use Basin Wrench to remove and install manifold couplings. Do not over tighten.

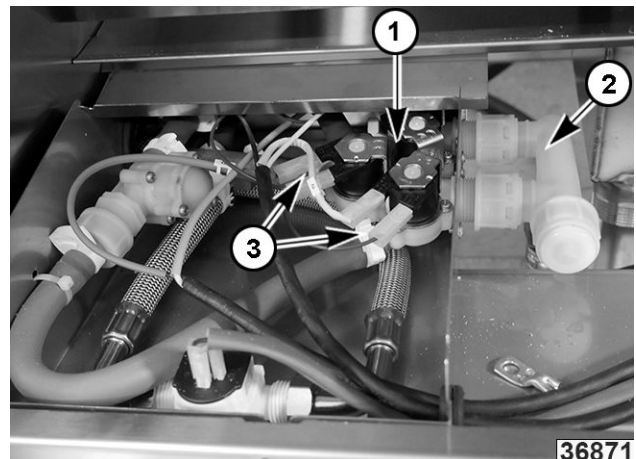

Fig. 23

5. Document hose and wire locations attached to solenoid (1, Fig. 23).
 6. Loosen front and rear hose clamps to remove hoses (3, Fig. 23).
- NOTE:** Valves will require catch pan for excess water.
7. Remove solenoid assembly mounting screws.

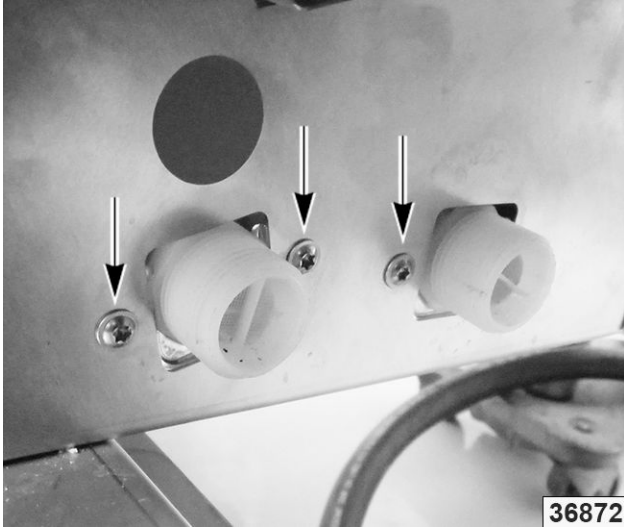

Fig. 24

8. Remove solenoid assembly from unit.
9. Remove solenoid (2, Fig. 23).
10. Reverse procedure to install.
11. Turn on water supply.
12. Verify proper operation for and check for leaks.

FLOW METER (Bd)

1. Drain unit.
2. Turn off water supply.



⚠ WARNING

Disconnect the electrical power to the machine and follow lockout / tagout procedures.

3. Remove UTILITY COVER.
4. Note and disconnect wires (1, Fig. 25).

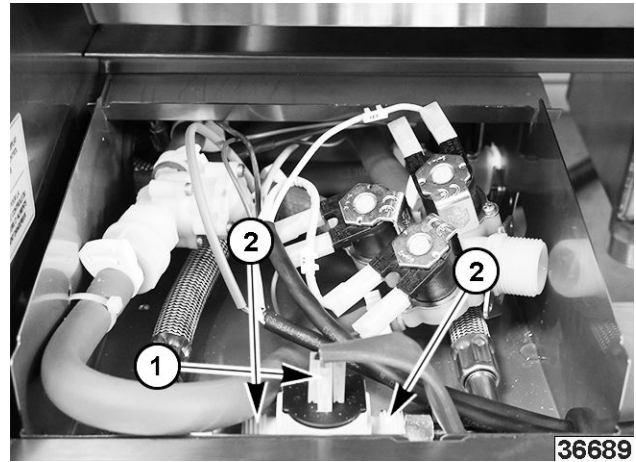

Fig. 25

5. Remove water lines (2, Fig. 25), while applying supporting pressure.
- NOTE:** Valves will require catch pan for excess water.
6. Remove screws.

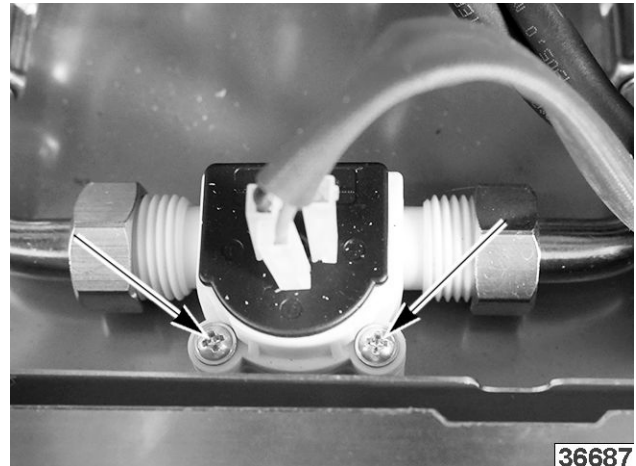

Fig. 26

7. Reverse procedure to install.
8. Turn on water supply.
9. Verify proper orientation and check for leaks.

SINGLE SOLENOID (HOT WATER) (Yec)

1. Drain unit.
2. Turn off water supply.



⚠ WARNING

Disconnect the electrical power to the machine and follow lockout / tagout procedures.

3. Remove UTILITY COVER.

4. Remove WATER SUPPLY MANIFOLD (COLD WATER SUPPLY).
5. Remove 3-WAY SOLENOID (Yef, Yv, Yd).

NOTE: Document hose and wire locations attached to solenoid.

6. Remove outside solenoid mounting screws.

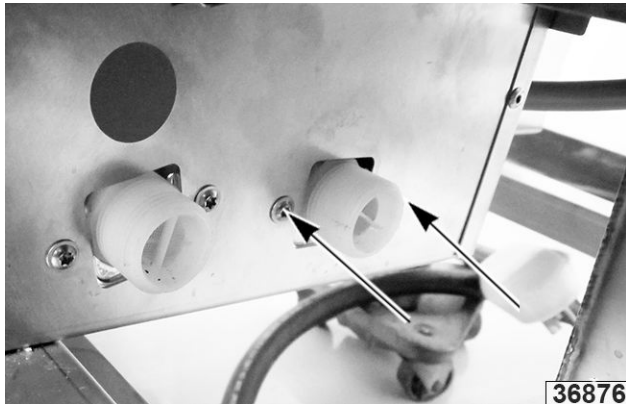

Fig. 27

7. Loosen hose clamps to remove hose on single solenoid.

NOTE: Valve will require catch pan for excess water.

8. Remove solenoid mounting screws and remove solenoid from unit.

NOTE: 3-way solenoid Shown in , 1-way is located under 3-way solenoid

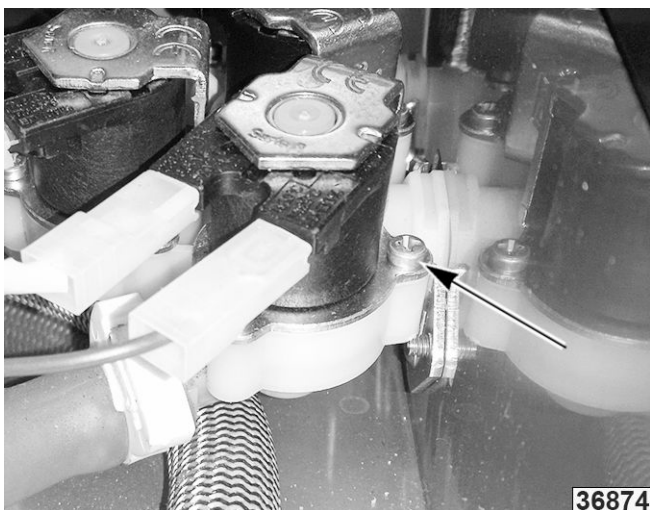

Fig. 28

9. Reverse procedure to install.
10. Turn on water supply.
11. Verify proper operation and check for leaks.

WATER SUPPLY MANIFOLD (COLD WATER SUPPLY)

NOTE: Manifold is used when cold water only is supplied. Blue dot, cold water only side. (1, Fig. 29).

1. Drain unit.
2. Turn off water supply.



⚠ WARNING

Disconnect the electrical power to the machine and follow lockout / tagout procedures.

3. Remove UTILITY COVER.
4. Remove 3-WAY SOLENOID (Yef, Yv, Yd).
5. Remove supply water hose (4, Fig. 29).

NOTE: Catch pan for excess water is required.

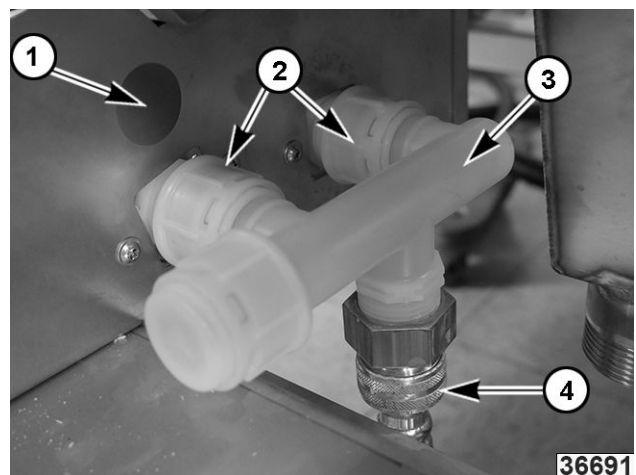

Fig. 29

6. Loosen couplings (2, Fig. 29) and remove manifold (3, Fig. 29) from unit.
7. Reverse procedure to install.
8. Turn on water supply.
9. Verify proper operation and check for leaks.

PRESSURE REGULATOR

1. Drain unit.
2. Turn off water supply.



WARNING

Disconnect the electrical power to the machine and follow lockout / tagout procedures.

3. Remove UTILITY COVER.

NOTE: Document pressure regulator valve orientation.

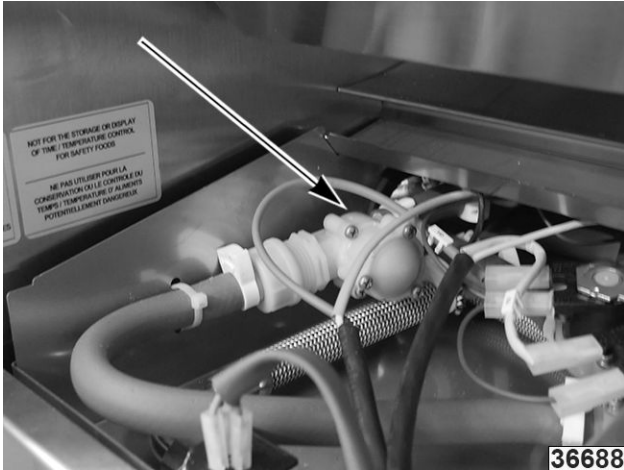

Fig. 30

4. Remove hose clamps on both valve ends.
5. Reverse procedure to install.
6. Turn on water supply.
7. Verify proper operation and check for leaks.

TOUCHSCREEN FASTPAD 2 (Af)



WARNING

Disconnect the electrical power to the machine and follow lockout / tagout procedures.

1. Remove CONTROL PANEL COVER.
2. Remove RIGHT SIDE PANEL.
3. Disconnect USB 2 extension cable and Encoder cable from FastPad 2 assembly.



Fig. 31

NOTE: Cables may be easier to remove after removing FastPad 2 screen.

4. Remove mounting screws to remove FastPad 2 assembly.

NOTE: Do not misplace springs.



Fig. 32

5. Slide screen support towards front of unit.
6. Reverse procedure to install.
7. Verify proper operation.

ENCODER KNOB

1. Remove encoder knob using allen wrench.
2. Disconnect cable.



Fig. 33

3. Replace encoder knob.

SPEAKER (BUZZER)



WARNING

Disconnect the electrical power to the machine and follow lockout / tagout procedures.

1. Remove CONTROL PANEL COVER.
2. Remove RIGHT SIDE PANEL.
3. Remove screws (1, Fig. 34) to remove display board cover.

NOTE: Disconnect buzzer connection cable (2, Fig. 34).

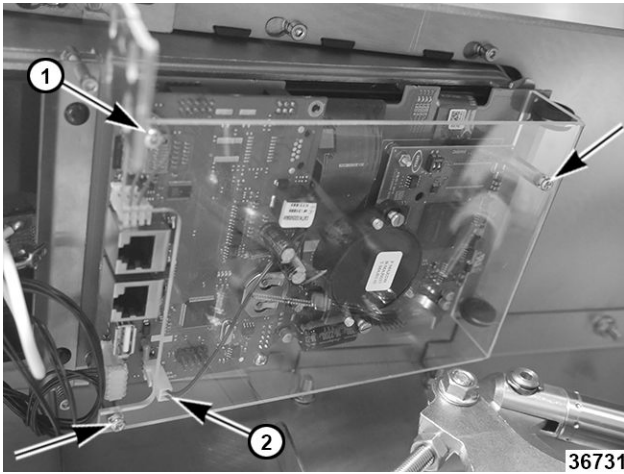

Fig. 34

4. Reverse procedure to install.
5. Verify proper operation.

POWER INPUT AND OUTPUT BOARDS (Ar1 & Ar2)



⚠ WARNING

Disconnect the electrical power to the machine and follow lockout / tagout procedures.

1. Remove CONTROL PANEL COVER.
2. Reference CONTROL BOX ACCESS.

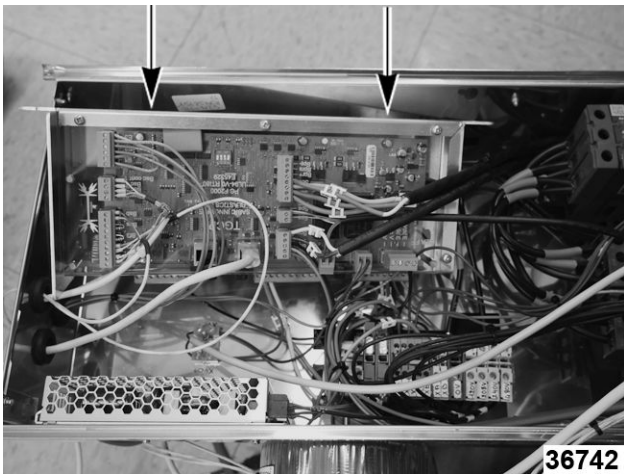

Fig. 35

3. Unplug cables.

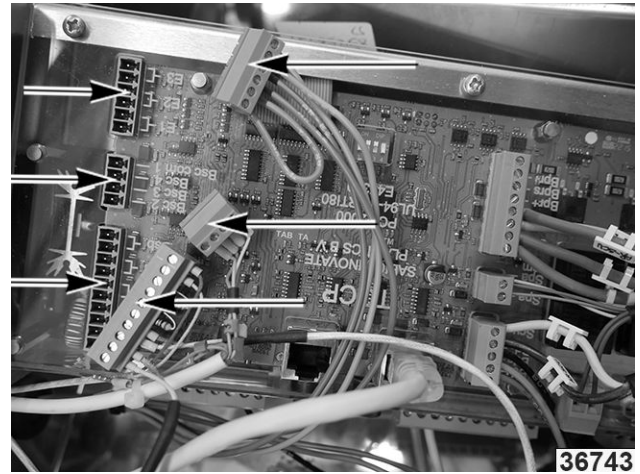

Fig. 36

4. Remove screws to replace assembly.

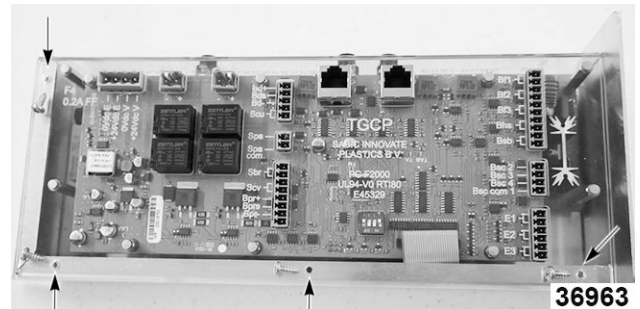

Fig. 37

5. Reverse procedure to reinstall.

NOTE: Verify dip switch settings on power input board (AR1).

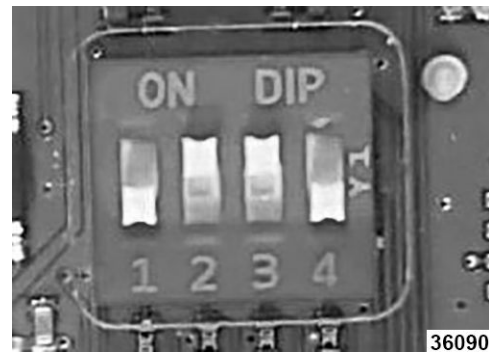

Fig. 38

6. Verify proper operation.

SWITCHING POWER SUPPLY (Ta)



WARNING

Disconnect the electrical power to the machine and follow lockout / tagout procedures.

1. Remove CONTROL PANEL COVER.
2. Remove RIGHT SIDE PANEL.
3. Pull out control box assembly.

NOTE: Document wire locations on board.

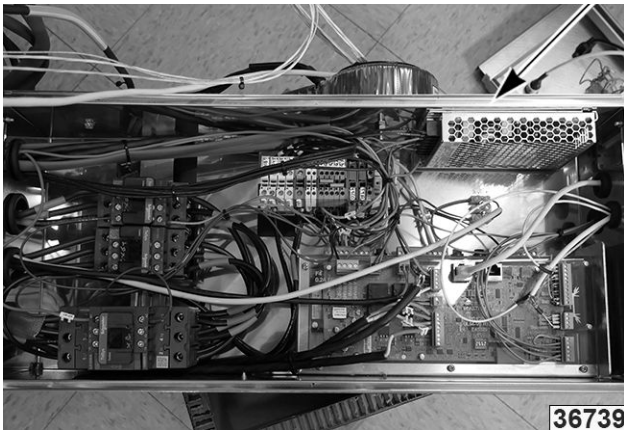

Fig. 39

4. Remove screws from outside of control box.

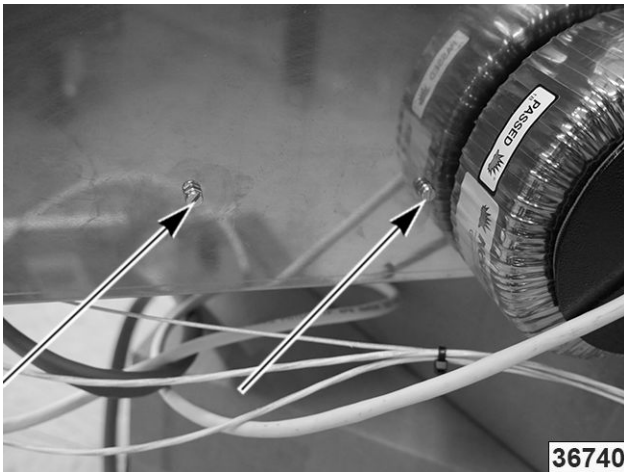

Fig. 40

5. Disconnect wires.
6. Reverse procedure to install.
7. Verify proper operation.

SNAP ACTION SWITCHING (Scm & Scd)



WARNING

Disconnect the electrical power to the machine and follow lockout / tagout procedures.

1. Remove CONTROL PANEL COVER.
2. Remove snap action switching with flat blade screw driver.

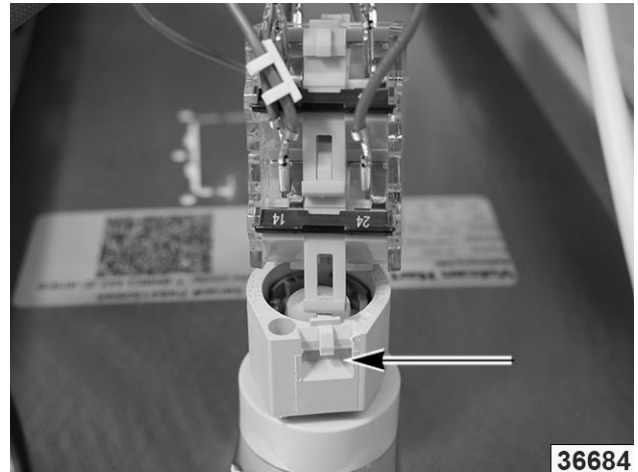

Fig. 41

3. Loosen screws to remove switch-3 positions selector.

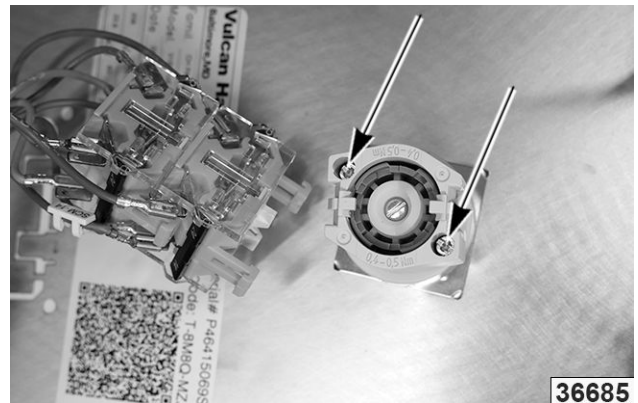

Fig. 42

4. Reverse procedure to install.
5. Verify proper operation.

HINGE COVER



⚠ WARNING

Disconnect the electrical power to the machine and follow lockout / tagout procedures.

1. Remove hinge cover screw.



Fig. 43

2. Slide cover away from lid to remove.
3. Reverse procedure to install.

BASKET LIFT RAM DETECTION SWITCH (Scu)



⚠ WARNING

Disconnect the electrical power to the machine and follow lockout / tagout procedures.

1. Remove HINGE COVER.
2. Remove mounting screw from right hand hinge cover and lift off.



Fig. 44

3. Remove basket lift ram detection switch.



Fig. 45



Fig. 46

4. Reverse procedure to install.

NOTE: When installing compress gap and slide into groove.



Fig. 47

5. Verify proper operation.

TRANSFORMER & SWITCHING POWER SUPPLY FUSES (Ftco & Fta)



WARNING

Disconnect the electrical power to the machine and follow lockout / tagout procedures.

1. Remove CONTROL PANEL COVER.
2. Slide control box forward, refer to CONTROL BOX ACCESS.

NOTE: Remove RIGHT SIDE PANEL to access cable ties is necessary.



Fig. 48

3. Release fuse holder to access fuse.

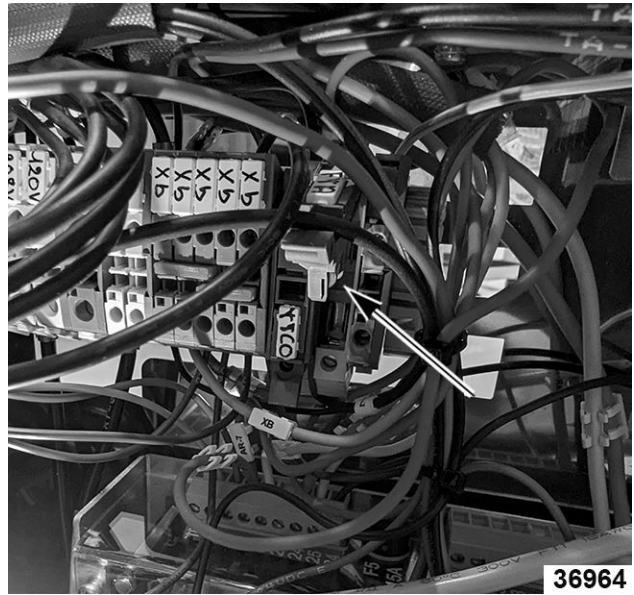

Fig. 49

4. Release fuse from front to back using a small tool.

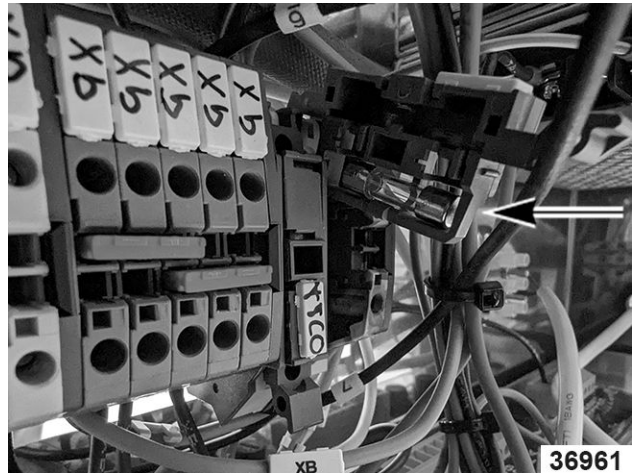

Fig. 50

5. Reverse procedure to reinstall.
6. Verify proper operation.

HEATING ELEMENTS (R1, R2, R3)

1. Drain unit.
2. Turn off water supply.



WARNING

Certain procedures in this section require electrical test or measurements while power is applied to the machine. Exercise extreme caution at all times and follow Arc Flash procedures. If test points are not easily accessible, disconnect power and follow Lockout/Tagout procedures, attach test equipment and reapply power to test.

3. Remove FRONT PANEL.
4. Fully tilt pan forward.



Fig. 51



WARNING

Disconnect the electrical power to the machine and follow lockout / tagout procedures.

5. Disconnect fans and remove fan cover.
6. Remove drain hose from pan drain, located beneath pan.

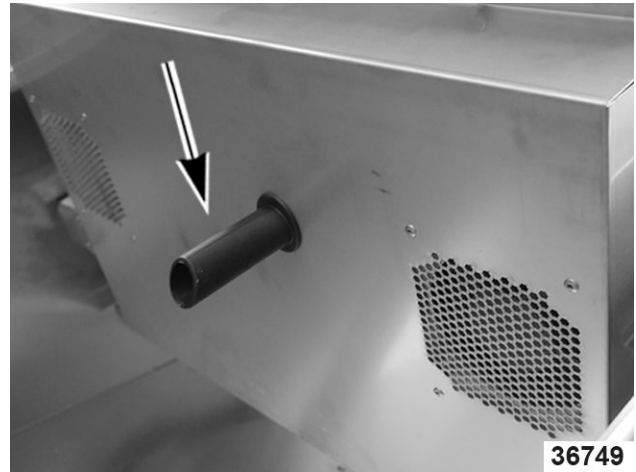

Fig. 52

7. Document all element wires and take photos of element wire positions before removing.

NOTICE

Support stud on element with 7 mm wrench while using a 8 mm socket to remove nuts.

8. Remove element wires and nuts.

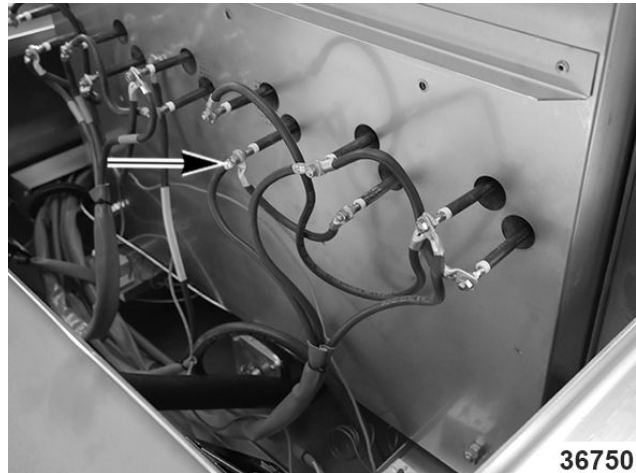

Fig. 53



Fig. 54

9. Note and disconnect FC1, FC2 and unmarked jumper wire from high limit to high limit. Loosen nuts on high limits with 14 mm wrench and set high limits out of way to remove heating element cover.

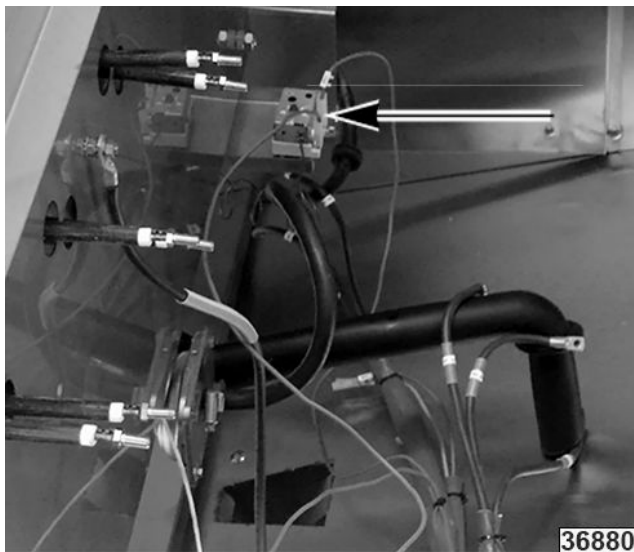

Fig. 55

10. Remove brass nuts from studs holding the heating element cover.



Fig. 56

NOTICE

Verify wires are not in the path of cover removal.

11. Slide heating element cover off unit. Carefully remove insulation board.



Fig. 57

12. Remove stand offs on element covers with 13 mm wrench. Remove upper and lower covers.

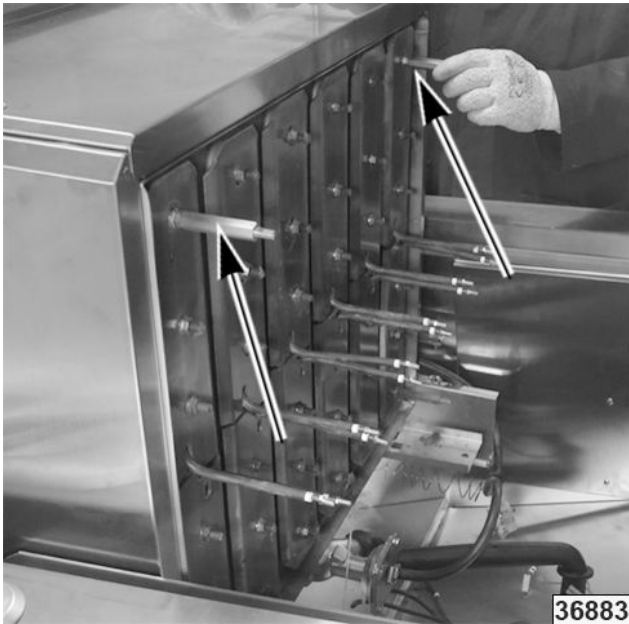

Fig. 58

13. Remove heating elements.
14. Reverse procedure to install.

NOTICE

Torque element cover nuts 4 to 7 in. lbs. Do not over torque.

NOTICE

Torque heating element wire nuts to 24 in. lbs. Do not over torque.

15. Verify proper operation.

HIGH LIMIT THERMOSTAT (Fc1, Fc2, Fc3)



WARNING

Disconnect the electrical power to the machine and follow lockout / tagout procedures.

1. Remove FRONT PANEL.
2. Remove nuts holding high limit bracket.

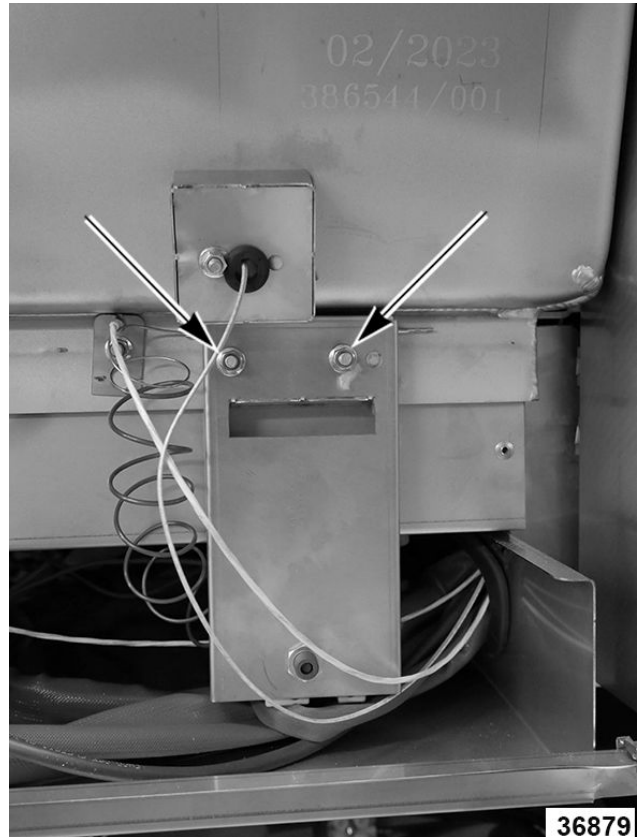

Fig. 59

3. Document orientation of high limit probe.

NOTE: When installing verify high limit probe is seated in cutout.

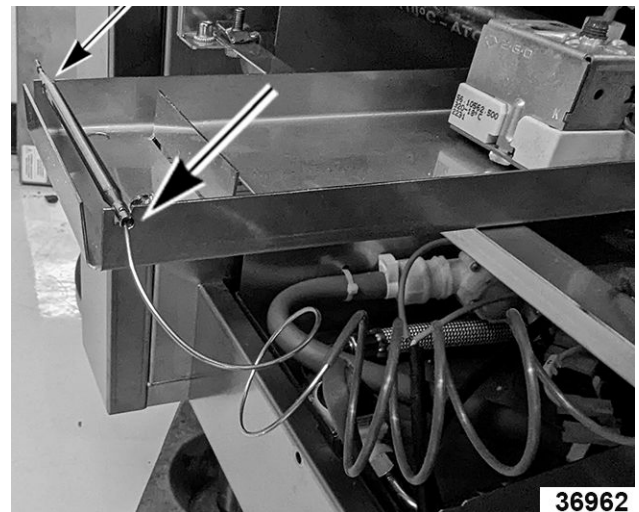

Fig. 60

4. Document and disconnect high limit thermostat wiring.
5. Unscrew jam nut.
6. Document high limit bulb orientation.

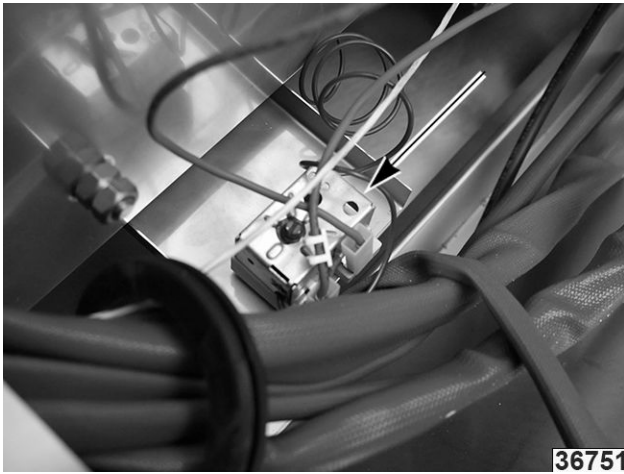

Fig. 61

7. Reverse procedure to install.
8. Verify proper operation.

TANK TEMPERATURE BASE PROBES (Bf1, Bf2, Bf3)



WARNING

Disconnect the electrical power to the machine and follow lockout / tagout procedures.

NOTE: VPP28 Model has two and VPP40 has three tank temperature base probes.

1. Remove FRONT PANEL.
2. Remove RIGHT SIDE PANEL.
3. Note and disconnect tank temperature base probe wire from control board.

NOTE: Refer to: SCHEMATIC / WIRING DIAGRAM.

4. Remove zip ties from wiring.

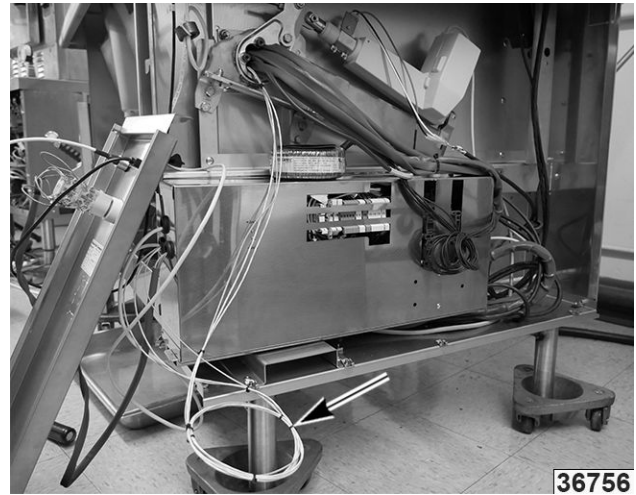

Fig. 62

5. Remove mounting nut on tank temperature base probe(s).
6. Reverse procedure to reinstall.
7. Verify proper operation.

TANK TEMPERATURE BASE (WELL) PROBE (B Sb)



WARNING

Disconnect the electrical power to the machine and follow lockout / tagout procedures.

1. Remove FRONT PANEL.
2. Remove CONTROL PANEL COVER.
3. Remove RIGHT SIDE PANEL.



Fig. 63

4. Remove nut from well probe cover.

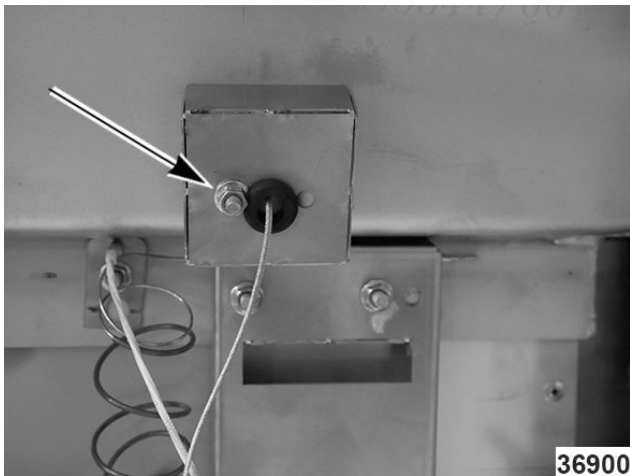

Fig. 64

5. Remove well probe insulation (1, Fig. 65).
6. Remove probe from mounting (2, Fig. 65).

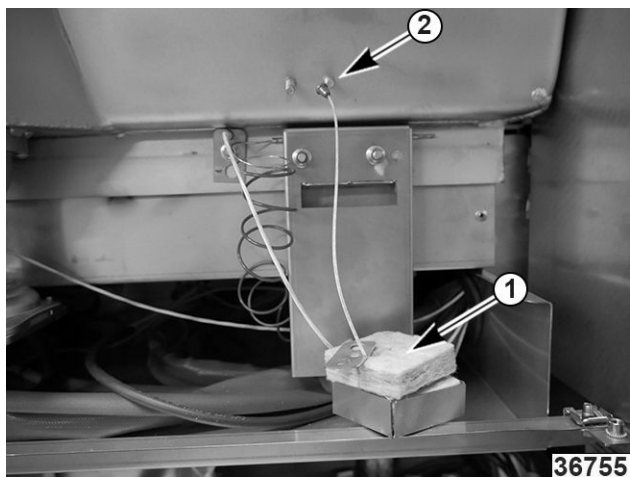

Fig. 65

7. Cut zip ties from well probe wiring.

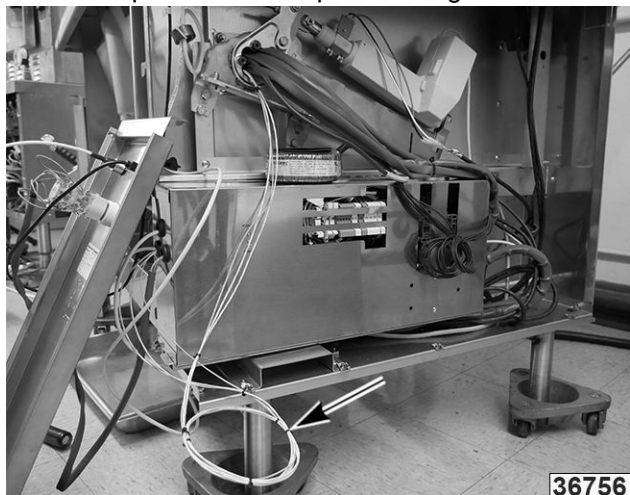

Fig. 66

8. Disconnect probe leads from power board assembly.

9. Tape leads to probe and route through control box. Reattach leads to power board assembly.



Fig. 67

NOTE: Refer to SCHEMATIC / WIRING DIAGRAM for lead connections.

10. Reverse procedure to install.
11. Verify proper operation.

3. SERVICE PROCEDURES TEST AND ADJUSTMENTS

TANK BACK LEVEL (TEST)

1. Place level on back of tank to check levelness of tank. If not level, proceed to TANK BACK LEVEL (ADJUSTMENT).

NOTE: Gap between level and chassis should be between 0 and .05 inches to 0 to 1.5mm.

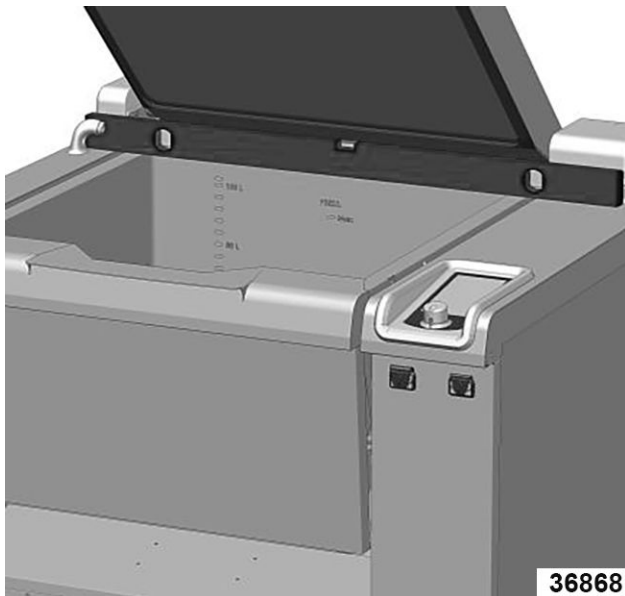

Fig. 68

TANK BACK LEVEL (ADJUSTMENT)



WARNING

Certain procedures in this section require electrical test or measurements while power is applied to the machine. Exercise extreme caution at all times and follow Arc Flash procedures. If test points are not easily accessible, disconnect power and follow Lockout/Tagout procedures, attach test equipment and reapply power to test.

1. Remove FRONT PANEL.
2. Remove CONTROL PANEL COVER.
3. Remove RIGHT SIDE PANEL.

4. Loosen screws on ram hand arm.

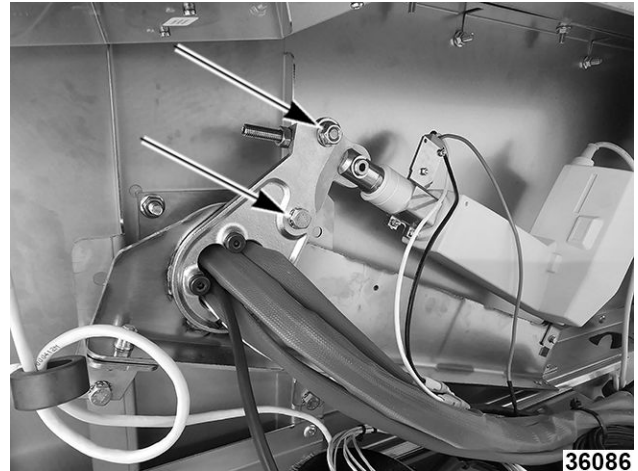

Fig. 69

5. Loosen lock nut (1, Fig. 70) and adjustment screw (2, Fig. 70) on adjustment arm on ram.

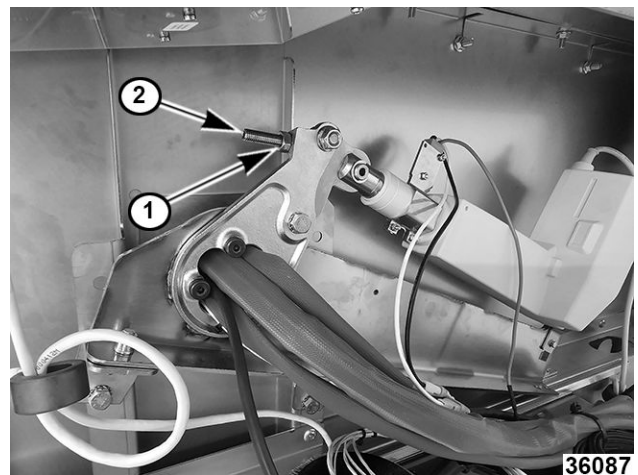

Fig. 70

6. Tilt tank forward to access tank stops.



Fig. 71

7. Remove rubber coverings from stop screws.



Fig. 72

8. Loosen or tighten lock nut (2, [Fig. 73](#)) to adjust the height of the tank stop screw (1, [Fig. 73](#)).

NOTE: Adjust both sides.

NOTE: One turn is equivalent to .06 inches or 1.5mm.



Fig. 73

9. Place rubber coverings on tank stop screw.
10. Lower tank and verify tank is level.

NOTE: If tank is not level, repeat steps and until level.

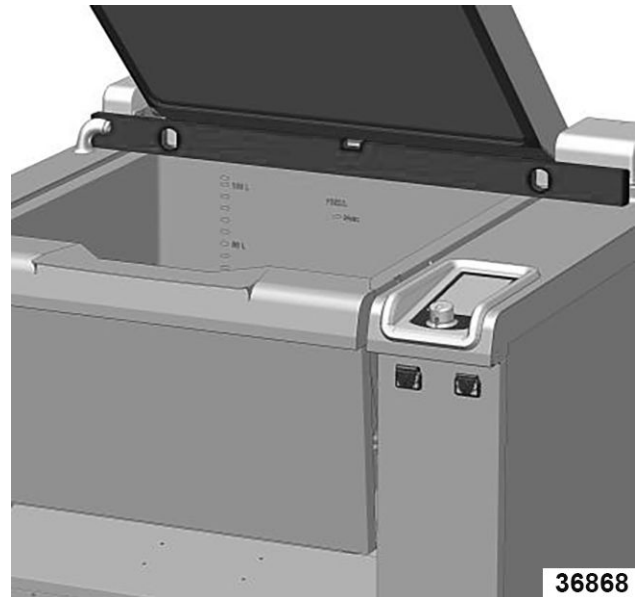

Fig. 74

11. Tighten lock nut and adjustment screw on adjustment arm on ram.
12. Tighten screws on ram hand arm.
13. Test level of tank. Refer to .
14. Remove level and place into service.

TANK FRONT LEVEL (TEST)

1. Open lid and place level on front of tank and side.

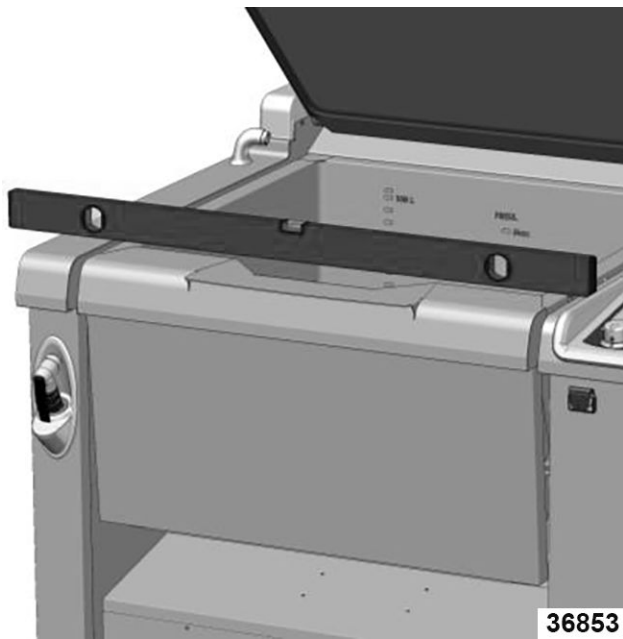

Fig. 75

2. Measure gap between level and chassis.

NOTE: Gap should be between 0 and .04 inches (0 to 1mm).



Fig. 76

3. If gap is greater than .04 inches, refer to TANK FRONT LEVEL (ADJUSTMENT).

TANK FRONT LEVEL (ADJUSTMENT)



⚠ WARNING

Certain procedures in this section require electrical test or measurements while power is applied to the machine. Exercise extreme caution at all times and follow Arc Flash procedures. If test points are not easily accessible, disconnect power and follow Lockout/Tagout procedures, attach test equipment and reapply power to test.

1. Remove FRONT PANEL.
2. Remove CONTROL PANEL COVER.
3. Remove RIGHT SIDE PANEL.
4. Loosen screws on ram hand arm.

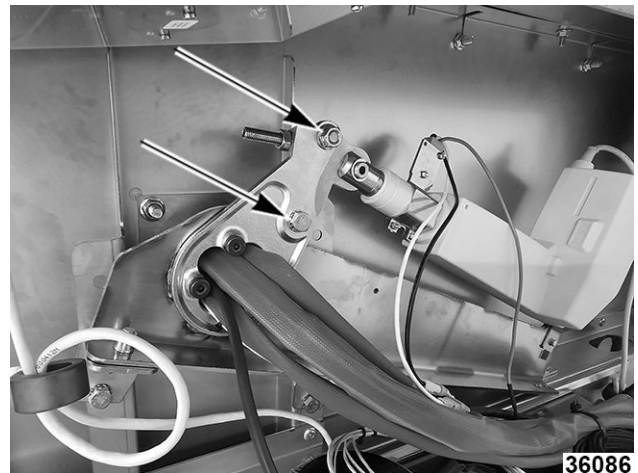

Fig. 77

5. Loosen lock nut (1, Fig. 78) and adjustment screw (2, Fig. 78) on adjustment arm on ram.

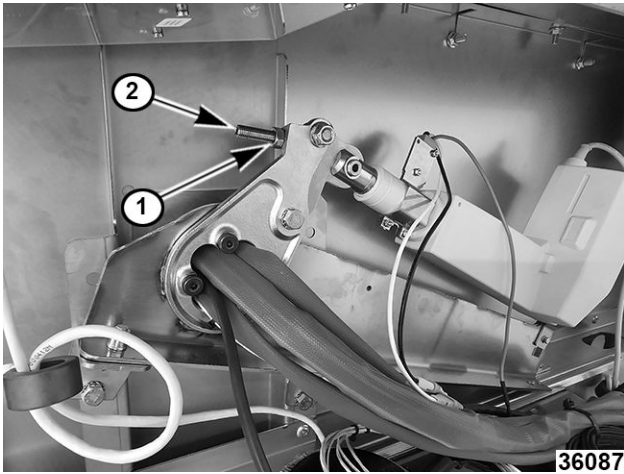

Fig. 78

6. Loosen tank axis screws on both sides of tank.

NOTE: Do NOT remove screws from axis.

Left Side

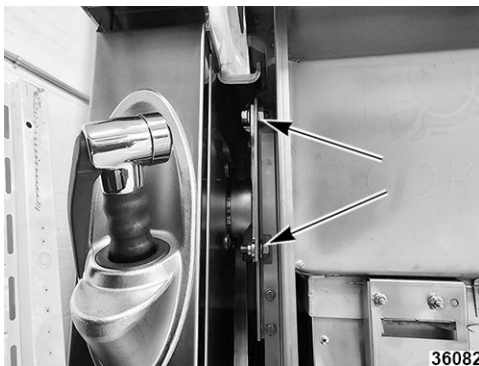

Fig. 79

7. Tilt tank forward.

8. Loosen tank axis screws (1, Fig. 79 and Fig. 80) on both sides of tank.

NOTE: Do NOT remove screws from axis.

Left Side

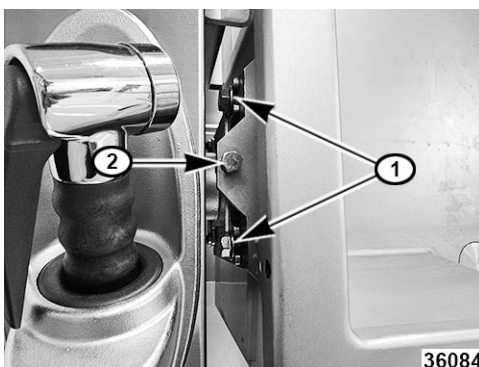

Fig. 81

9. Adjust top tank screws (2, Fig. 81 and Fig. 82) to raise and lower each side.
10. Lower tank.
11. Tighten screws on ram hand arm.
12. Tighten lock nut and adjustment screw on adjustment arm on ram.
13. Test tank level. Refer to TANK FRONT LEVEL (TEST).

LID COUNTERBALANCE (TEST)

NOTE: This test is to verify if lid remains open at a certain angle.

Lid Open

1. Cover remains open when front edge of lid is 15 inches (40 cm) above tank.

Right Side

NOTE: Lid should stay open in zone 1 (Fig. 83).

NOTE: Lid will close in zone 2 (Fig. 83).

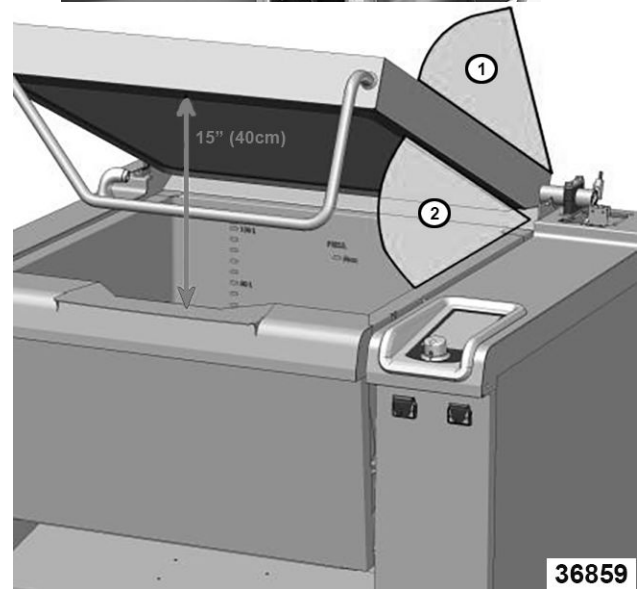

Right Side

Lid Closed

1. Cover closes properly onto tank.

NOTE: Lid should seal resting on the front of tank.

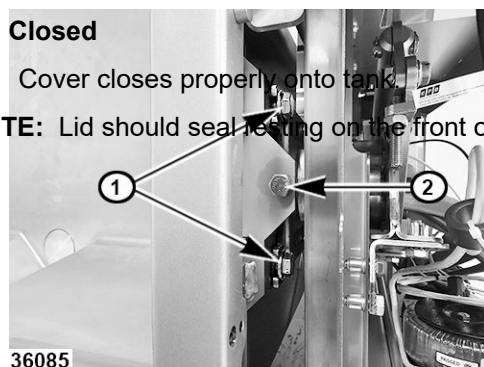
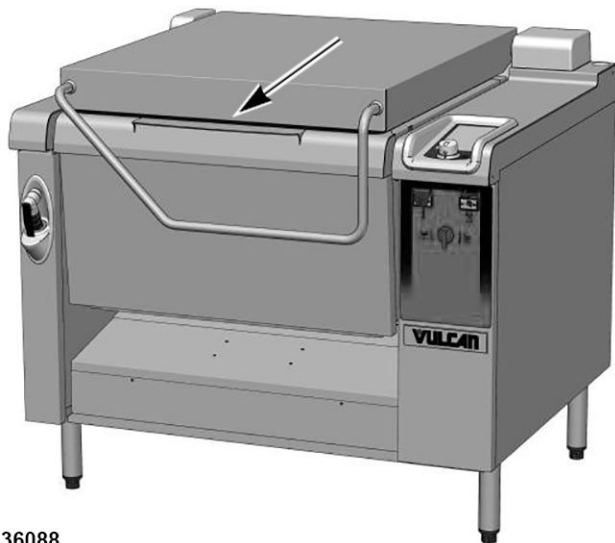

Fig. 82



36088

Fig. 84

LID COUNTERBALANCE (ADJUSTMENT)

NOTE: This adjustment increases or decreases the effort required to open or close lid.

1. Open lid.
2. Remove HINGE COVER.
3. Remove LEFT FRONT PANEL.
4. Remove LEFT SIDE PANEL.
5. Verify bearing mount screws are tighten to 88 in-lbs.

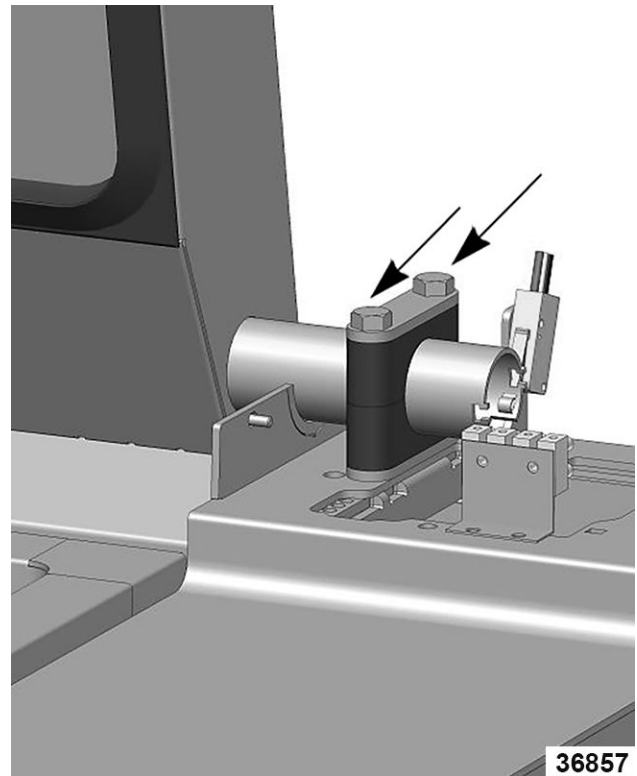

36857

Fig. 85

6. Turn threaded adjustment screw to tighten or loosen the tension on springs.

NOTE: Do not adjust tension unless lid is fully open.

NOTE: Do not over tighten springs, which would result in complete closure at the front.

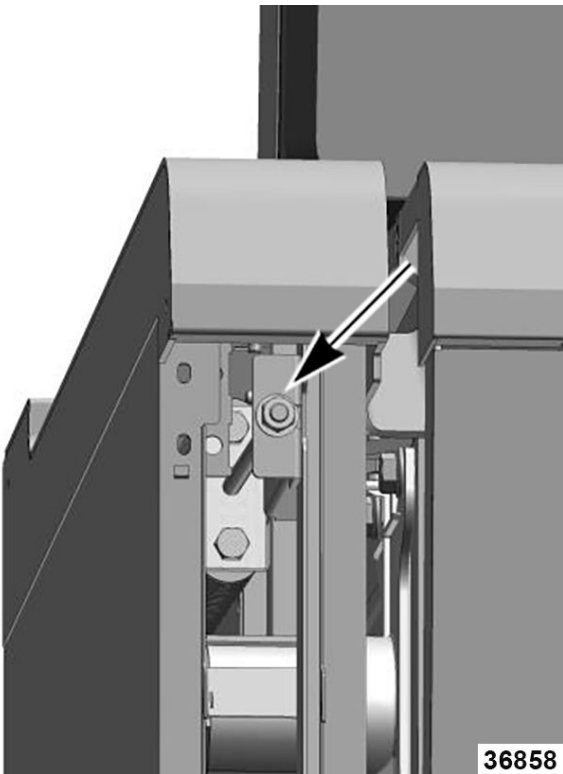

Fig. 86

NOTE: Factory tension set to 6-5/16 inches.

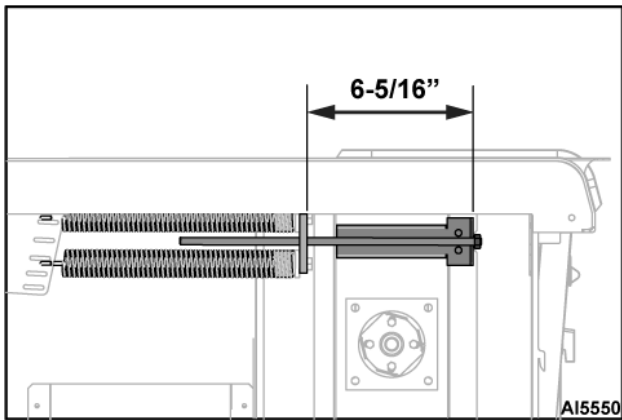

Fig. 87

7. Test lid adjustment. Refer to LID COUNTERBALANCE (TEST).
8. After adjustment, reinstall all panels removed.

HEATING ELEMENT MAINTENANCE - TEST

1. Select "TOOL BOX" option to enter screen.



Fig. 88

2. Select "Technical parameters" option.



Fig. 89

3. Enter password "SAVB".

NOTE: Password is not case sensitive.



Fig. 90

4. Select checkmark "☑" to enter.

NOTE: If code is entered correctly the menu screen will display. Otherwise, re-enter pin.



Fig. 91

5. Press "Next" button to scroll through different screens.

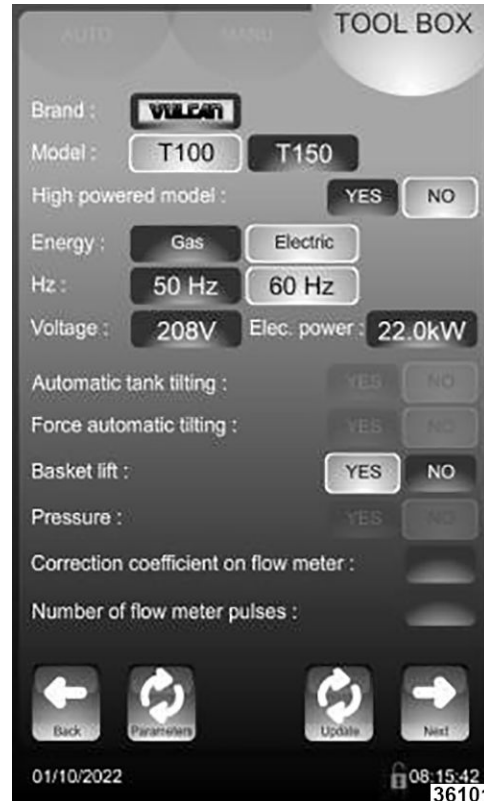

Fig. 92

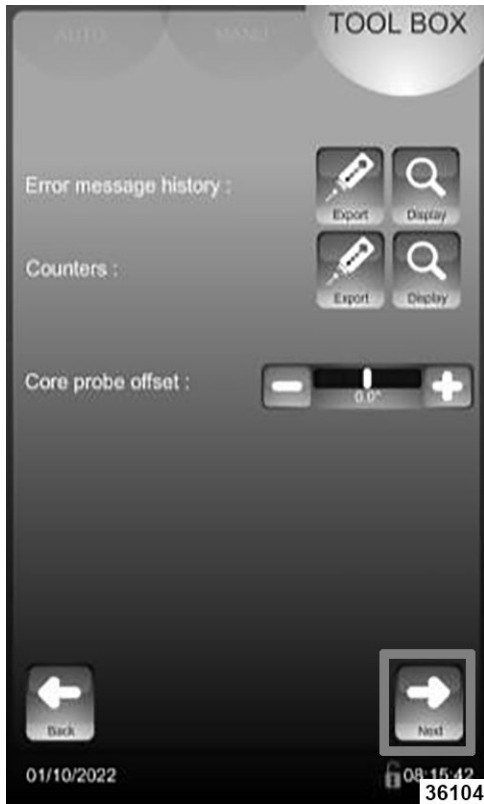

Fig. 93

6. Check contactors and diagram.

NOTE: Activate each touch to control operation of the contactor (visual check on the electrical support).

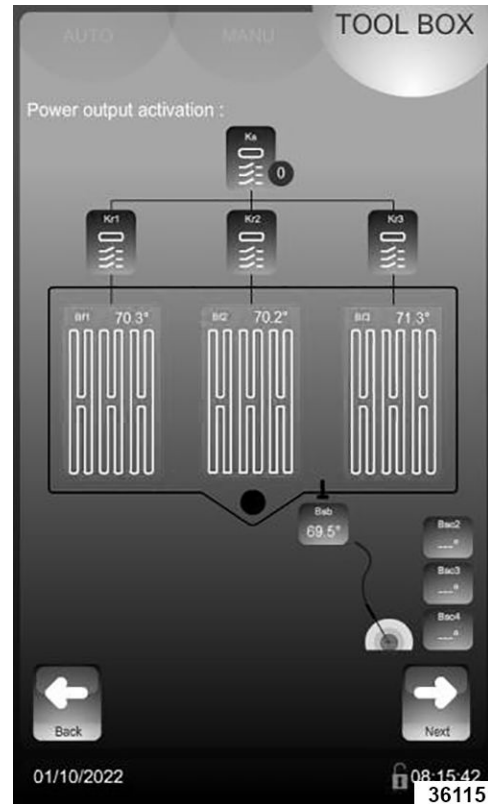

Fig. 94

7. Check GN heating zones: in Multi mode, enter a temperature setting at 140°F (60°C) zone per zone and check with the temperature on the bottom of the pan.
8. Check the associated contactor to the zone that is activated.

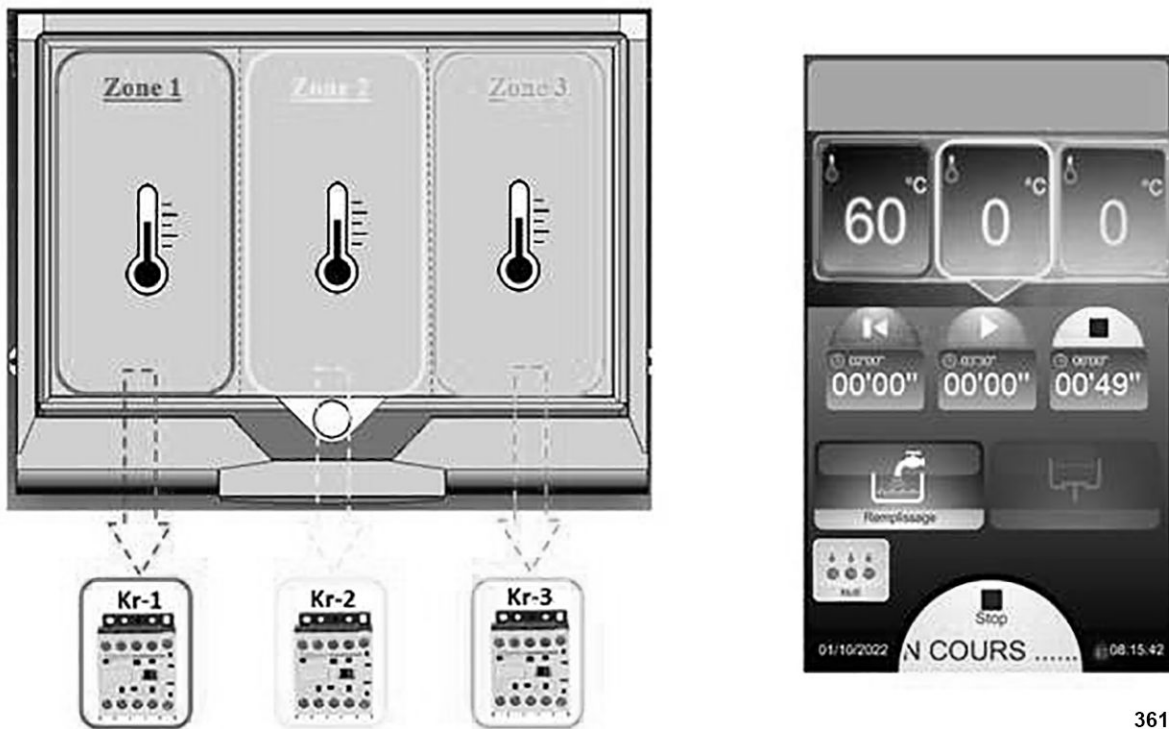

Fig. 95

36116

HEATING ELEMENT - TEST

Measure currents on main supply.

Model	Voltage	Current
T100	208 V	$57 \leq I (63.3) \leq 66.5$
	240 V	$45.3 \leq I (50.4) \leq 52.9$
	480 V	$30.2 \leq I (33.6) \leq 35.2$
T150	208 V	$85.5 \leq I (95) \leq 99.8$
	240 V	$68.0 \leq I (75.6) \leq 79.4$
	480 V	$45.3 \leq I (50.3) \leq 52.9$

Measure the currents per heating zone.

Model	Voltage	Current
T100	208 V	$29.1 \leq 32 \leq 33.6$
	240 V	$23.9 \leq 26.3 \leq 27.7$
	480 V	$15.9 \leq 17.5 \leq 18.4$
T150	208 V	$29.1 \leq 32 \leq 33.6$
	240 V	$23.9 \leq 26.3 \leq 27.7$
	480 V	$15.9 \leq 17.5 \leq 18.4$

NOTE: In case of value out of bound, disconnect heating element, and check ohm value.

Heating Element	Voltage	Ohms Min	Ohms Max
302278	208V	10.429	12.167
302294	240V / 480V	15.129	17.65

NOTE: If "OL" (open), replace the heating element.

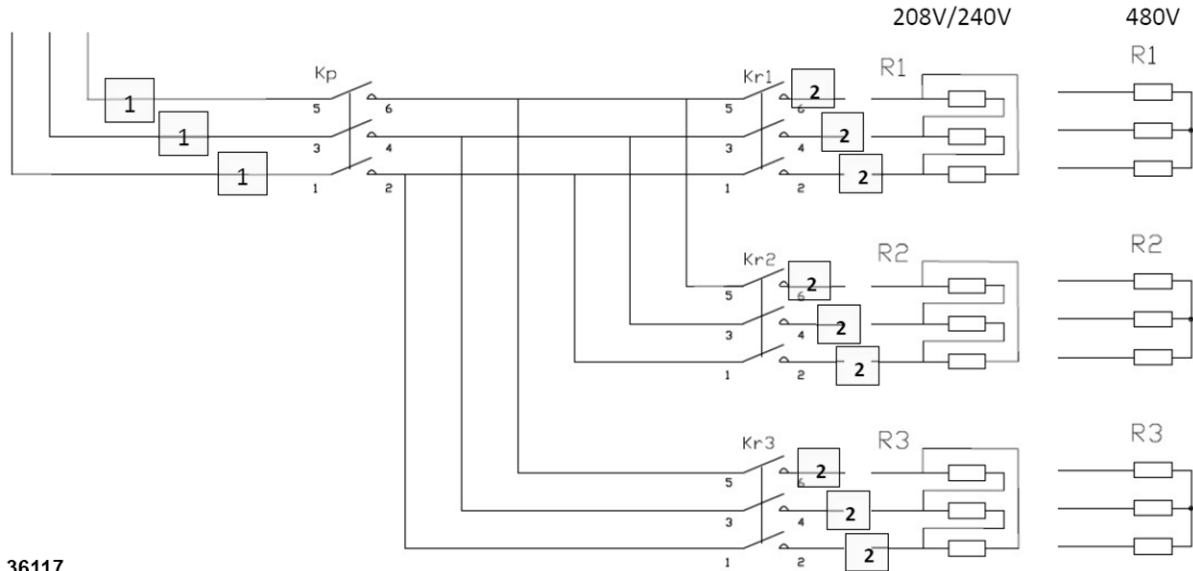

36117

Fig. 96

4. FIRMWARE / SOFTWARE

SOFTWARE CONTROL

NOTE: Current software is visible in "TOOL BOX" tab next to unit's serial number. Each card is identified with its software tag:

1. Select "TOOL BOX" option to enter screen.



Fig. 97



Fig. 98

Screen card sub assembly:

IHM - Fla: IHM - Flash Card

UC: UC card

Screen support card

Power carte

Rel: Power package

Check the following numbers according to their corresponding update file numbers:

Standard update file labels:

MAJ_FPV2_IHMwww_UC_FLAYyy_RELzzz_GTvww

IHM Nr www

UC Nr xxx

Fla Nr yyy

Rel Nr zzz

SOFTWARE VERSIONS

Release Date	Version	Comments
Nov 7, 2023	201-115-115b-107	Includes new recipes, screens, and improvements to user experience.

SOFTWARE UPDATE PROCEDURE

NOTE: The update procedure requires the use of a max 32GB, FAT32 formatted USB thumb drive.

NOTE: The following instructions require that you have access to the Hobart Service Resource Center.

Updating Software

1. Access control Tool Box to verify that the installed software version matches the latest version found in the Hobart Service Resource Center.

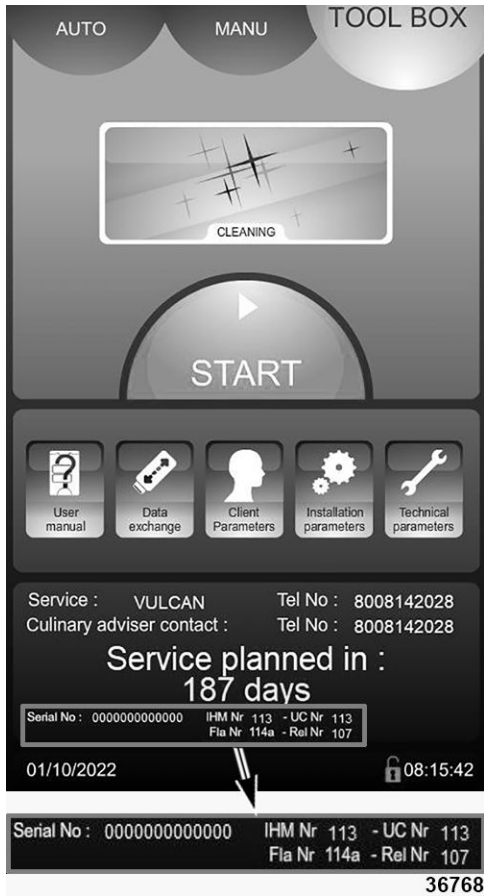

Fig. 99

2. If versions do not match, download the latest version software to the FAT32 thumb drive.
 - A. Go to Hobart Service Resource Center > Cooking > Software Updates > General > Product Category: Braising Pans > PreciPan Software.
 - B. Click "download" arrow to save the .zip file folder to the computer.

NOTE: PreciPan unit cannot read .zip files or other folders.

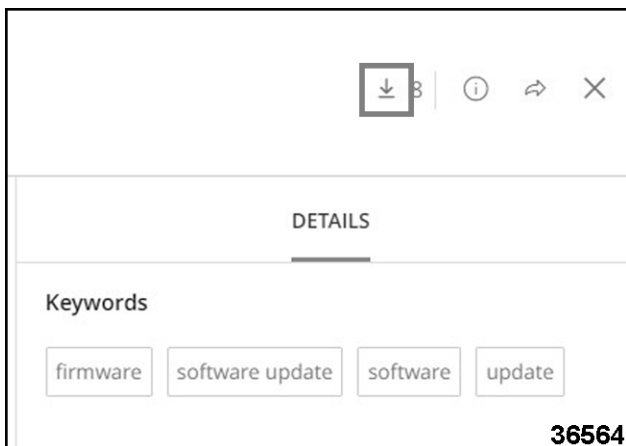

Fig. 100

- C. Extract or copy the MAJ folder and UPDATE.SSA file from the .zip file folder and paste to root menu of USB thumb drive.

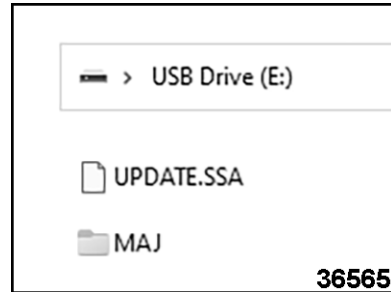

Fig. 101

3. Go to Tool Box screen on PreciPan, and insert thumb drive into USB port on unit.
4. Select YES when prompted to proceed with update.



Fig. 102

5. Allow software to update. PreciPan will restart when update is complete.



Fig. 103

6. Verify software code has been updated in Tool Box.

Setting Auto Lock

NOTE: Auto Lock feature reduces the risk of accidental touches of screen or knob - disrupting cooking function - after cooking has started (moisture function included). During cooking, display will show a red lock symbol (Fig. 104). Screen must be unlocked by sliding the symbol to the right before any changes to cooking function may be made.

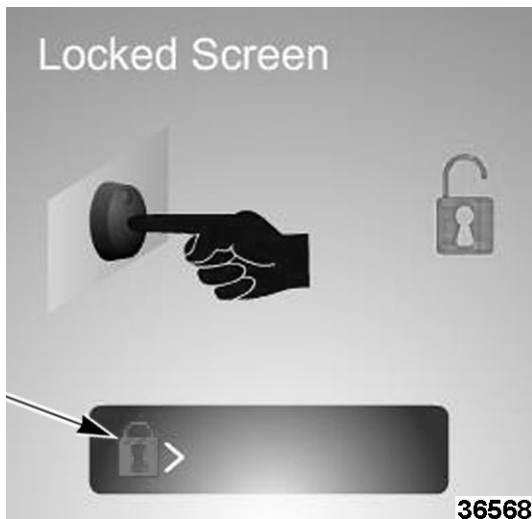

Fig. 104

1. Go to Tool Box and select Client Parameters.



Fig. 105

2. Enter passcode **0000**.
3. On each of the next three screens, select "Next" arrow at the bottom right-hand corner of screen, until Auto Lock Screen appears.
4. Select YES to activate Auto Lock, then select "Back" arrow three times to exit out of Client Parameters.

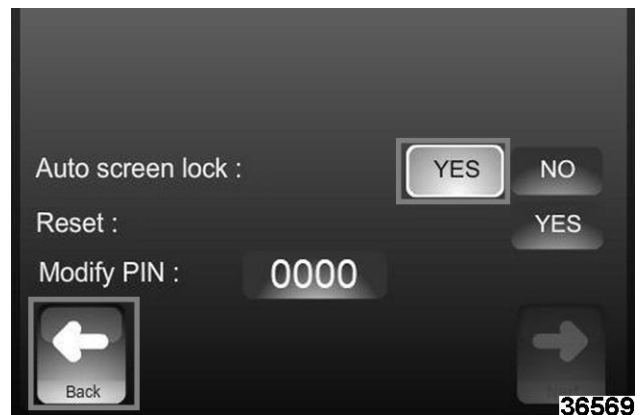

Fig. 106

5. PROGRAMMING

PARAMETER ACCESS

1. Enter "Tool Box" tab.



Fig. 107

2. Select "Technician parameters."



Fig. 108

3. Enter password (SAVB).

NOTE: Password is not case sensitive.



Fig. 109



Fig. 110

4. Press green checkmark to validate (☑).

NOTE: If code is entered correctly the menu screen will display. Otherwise, re-enter pin.

5. Reconfigure the machine.

- A. Select zone of the value to be modified.
- B. Adjust setting with coder.

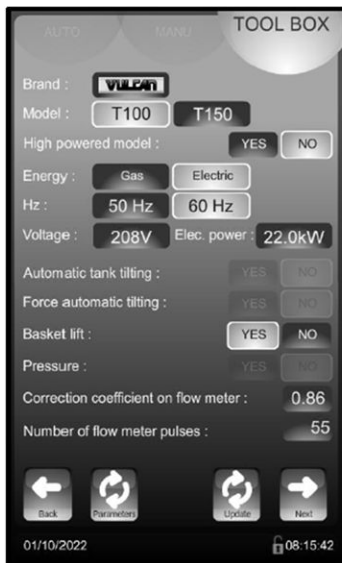

- Commercial brand of the appliance
- Model: Unit capacity
- Export historic error messages to USB stick (Excel compatible format) ←
- Export historic counter data to USB stick (Excel compatible format) ←
- Core probe calibration ←
- Basket lift
- Flow meter adjustment parameter
- Flow meter signal frequency



Fig. 111

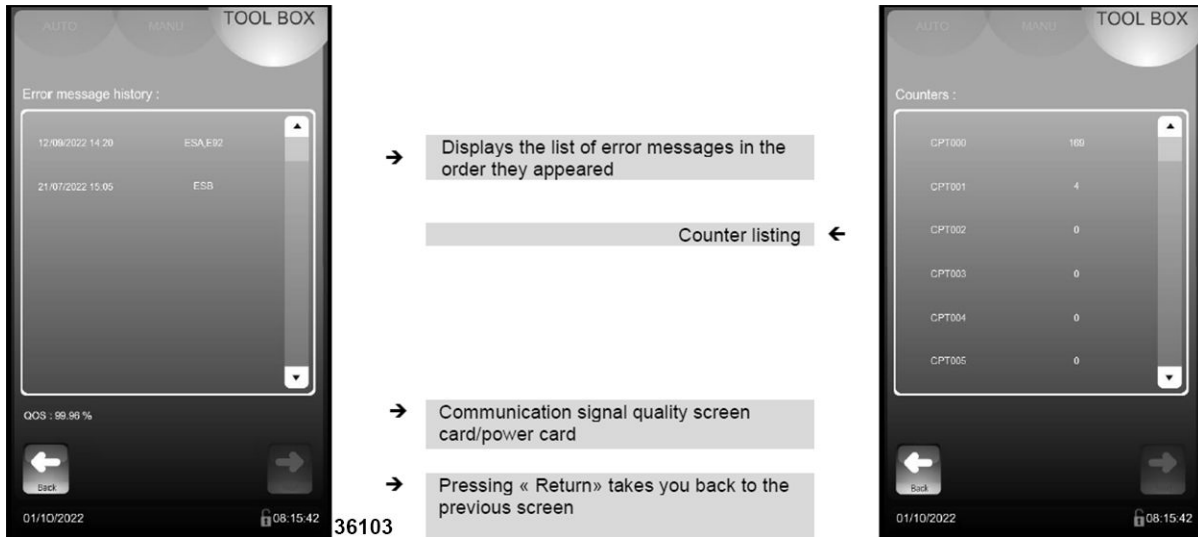

Fig. 112

PARAMETERS - COUNTERS

Counters	
CPT00	Duration of operation in total = SWITCHED ON (excludes cooking cycles)
CPT01	Duration of cooking in Bratt pan mode
CPT02	Duration of cooking in Boiling pan mode
CPT03	Not used
CPT04	Not used
CPT05	Not used
CPT06	Duration (!) or T° electronics > 70°C cumulative
CPT07	Duration total functioning IN CYCLE (all modes)
CPT08	Number of lid openings
CTP09	Not used
CPT10	Volume of water flow meter (liters)
CPT11	Number of cycles S7 / Rel13 - Safety
CPT12	Duration of operation S7 / Rel13 (contact closed) - Safety
CPT13	Number of cycles S8 / Rel10
CPT14	Duration of operation S8
CPT15	Number of cycles S22
CPT16	Duration of operation S22
CPT17	Number of cycles S18
CPT18	Duration of operation S18
CPT19	Number of cycles S30 / Rel20 – condenser solenoid
CPT20	Duration of operation S30 / Rel20 - condenser solenoid
CPT21	Number of cycles S10 - drain solenoid
CPT22	Duration of operation S10 - drain solenoid

CPT23	Number of cycles S9 – spray hose solenoid
CPT24	Duration of operation S9 – spray hose solenoid
CPT25	Number of cycles relay Vp+
CPT26	Number of cycles relay Vp-
CPT27	Number of cycles relay Vc+
CPT28	Number of cycles relay Vc-

MAINTENANCE COUNTER RESET

NOTE: If time remaining before the next maintenance is less than or equal to 0, error code i84 will be displayed in error codes. Refer to ERROR AND INFORMATION CODES.

1. Enter service tab.



Fig. 113

2. Select "Installation parameters".



Fig. 114

3. Enter installer PIN (INSB).



Fig. 115

4. Press green checkmark to validate (☑).

NOTE: If code is entered correctly the menu screen will display. Otherwise, re-enter pin.



Fig. 116

5. Reset remaining time before service: "YES".

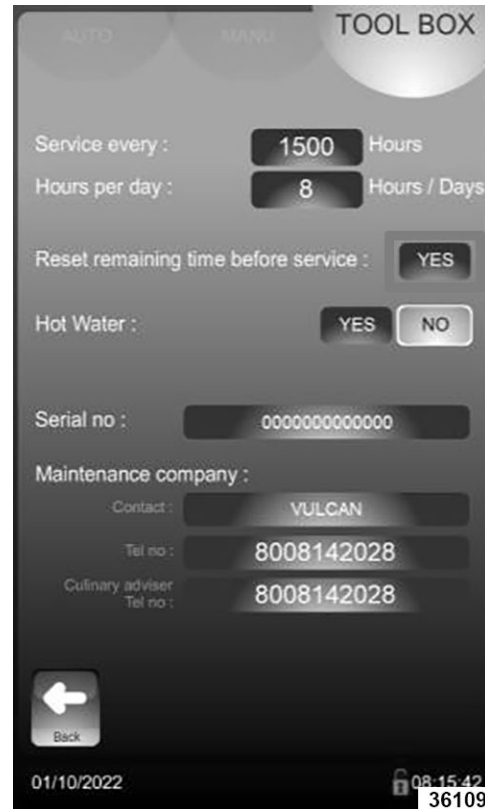

Fig. 117

6. System will ask to verify before resetting.

- A. YES: Resets system counter.
- B. NO: Cancels request.



Fig. 118

SOFTWARE LANGUAGE SETTING

1. Select "TOOL BOX" option.



Fig. 119

2. Select "Client Parameters" option.



Fig. 120

3. Enter password "CHEF."

NOTE: Password is not case sensitive.



Fig. 121

4. Select checkmark "☑" to enter.

NOTE: If code is entered correctly the menu screen will display. Otherwise, re-enter pin.



Fig. 122

5. Select language.

NOTE: Use encoder knob to select preferred language.

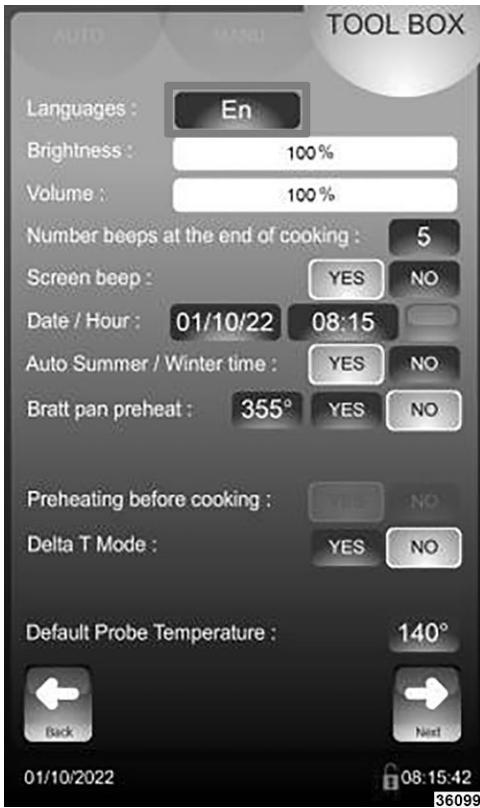

Fig. 123

6. Select "Back" to return to previous menu.

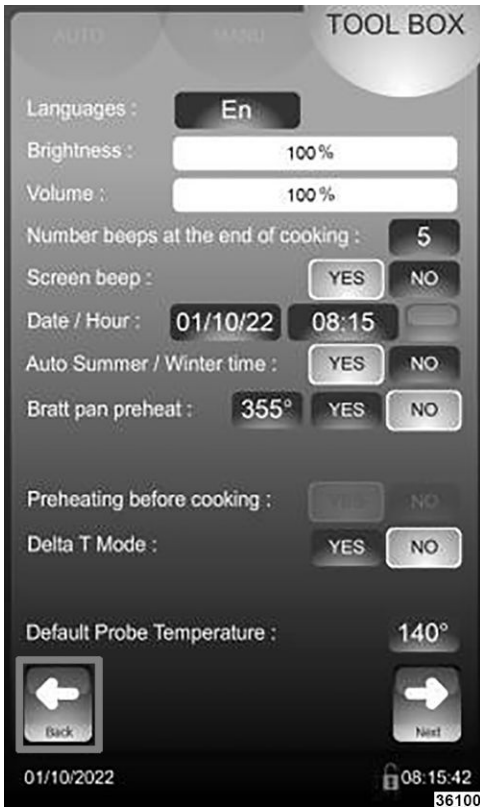

Fig. 124

SERIAL NUMBER ACCESS

1. Select "TOOL BOX" option to enter screen.



Fig. 125

2. Serial number is displayed.



Fig. 126

FREQUENCY MAINTENANCE USAGE PER DAY ADJUSTMENT

NOTE: Frequency between two maintenance visits and rate of use per day have been entered according to information (number of hours per day/type of cooking) provided by the customer during installation.

NOTE: Technicians should check settings against the actual use of the appliance and modify them if necessary (according to the table below):

Type of Use (Client Information)	Hours of Use / Day (Customer Information)		Adjusting Installation Parameters	
			Maintenance Regularity (hours)	Hours per Day (hours)
Normal Use	Light	<5	1500	5
	Standard	5-10	2000	10
	Intensive	10-15	2500	15
	Very Intensive	15-24	3000	24

1. Enter "TOOL BOX" tab.



Fig. 127

2. Select "Installation parameters".



Fig. 128

3. Enter installer PIN (INSB).



Fig. 129

4. Press green checkmark to validate (✓).

NOTE: If code is entered correctly the menu screen will display. Otherwise, re-enter pin.



Fig. 130

5. Enter number of hours before next service (1500 default): Adjustable from 100 to 5000 hours. Allow for at least one service per year.
 - A. Select value to be modified.
 - B. Adjust setting with coder.

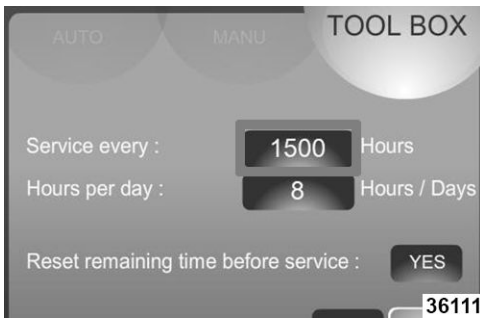

Fig. 131

6. Enter average level of use in hours per day: Adjustable from 1 to 24.
 - A. Select value to be modified.
 - B. Adjust setting with coder.

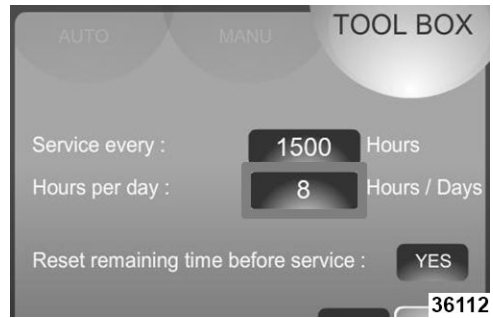

Fig. 132

7. Select "Back" to return to main menu.

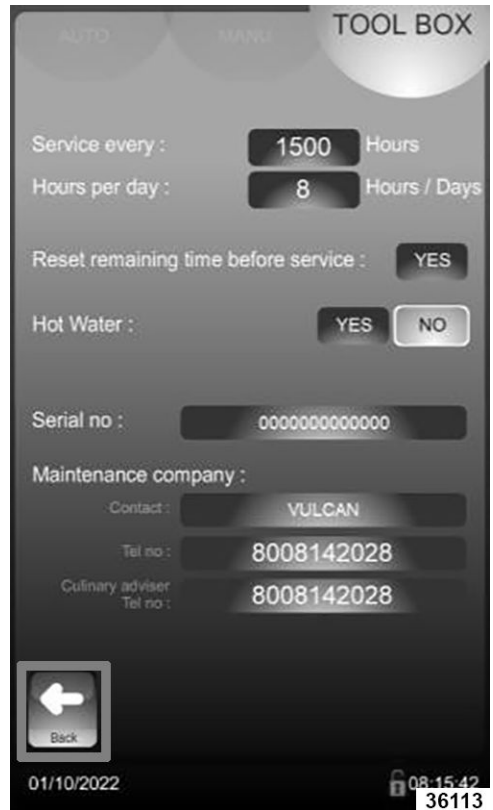

Fig. 133

6. ELECTRIC OPERATION

COMPONENT LOCATION & FUNCTION - FASTPAD 2 INPUT BOARD (AR1)

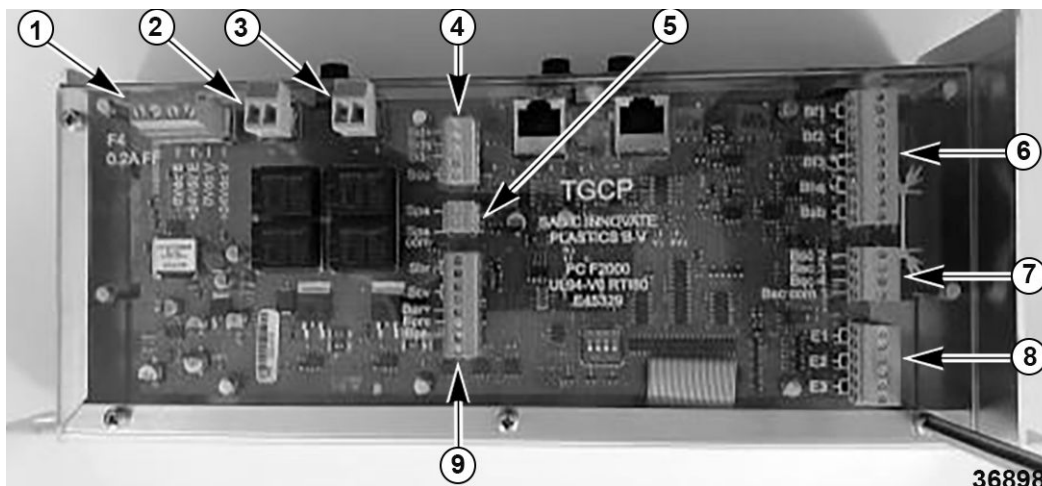

Fig. 134

Number	Component / Electrical Callout	Function
1	Switching Power Supply Connection (Xa, Xb)	Supplies 24 VDC from Switching Power Supply (Ta)
2	Tank RAM Motor Connection (Xvc1, Xvc2)	Supplies 24 VDC to Tank RAM Motor (Vc)
3	Basket Lift RAM Connection (Xd1, Xd2)	Supplies 24 VDC to Basket Lift Ram Detection Switch (Sbr)
4	Flow Meter Connection (Bd+, Bd-, Bbs)	Supplies 24 VDC to Flow Meter (Bd)
5	Lift Arm RAM Connection SPA / SPAcom (Xd3, Xd4)	Supplies 24 VDC to Lift RAM Arm (Scv)
6	Tank Temperature Base Probe Connection (Bf1, Bf2, Bf3, BSb)	Reads resistance from Tank Base Probe and Tank Probe.
7	Core Probe Connection (B sc 4, B sc 3, B sc 2)	Reads resistance from Core Probe
8	Snap Action Switching Connection (E2, E3)	Supplies 24 VDC to Snap Action Switching (Scm & Scd)
9	Basket Lift RAM Reed Detector Connection (Sbr)	Supplies 24 VDC to Basket Lift Ram Detection Switch

COMPONENT LOCATION & FUNCTION - FASTPAD 2 OUTPUT BOARD (AR2)

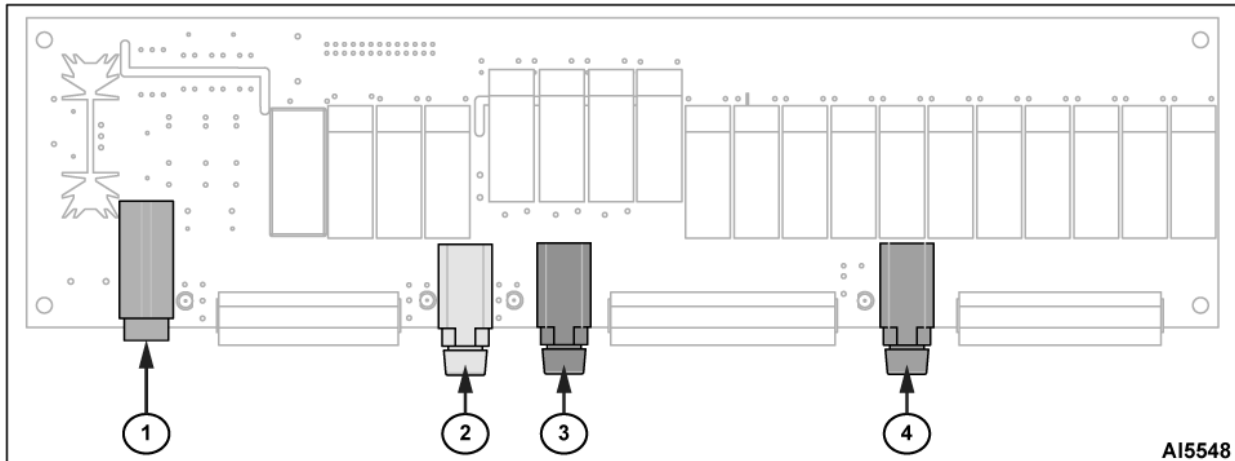

Fig. 135

Number	Component / Electrical Callout	Function
1	Fuse (F4)	0.2A slow blow fuse. Provides over current protection for 3 way solenoid drain water valve (Yv) and 3 way solenoid spray hose (Yd).
2	Fuse (F2)	0.1A slow blow fuse. Not applicable with this unit.
3	Fuse (F1)	3.1A slow blow fuse. Provides over current protection for right heating contactor (Kr3), 3 way solenoid cold water valve (Yef) and single solenoid hot water valve (Yec).
4	Fuse (F5)	3.15A slow blow fuse. Provides over current protection for left technical fan motor (Mt1), right technical fan motor (Mt2), high limit thermostats (Fc1, Fc2, Fc3), left heating contactor (Kr1), and right / middle heating contactor (Kr2).

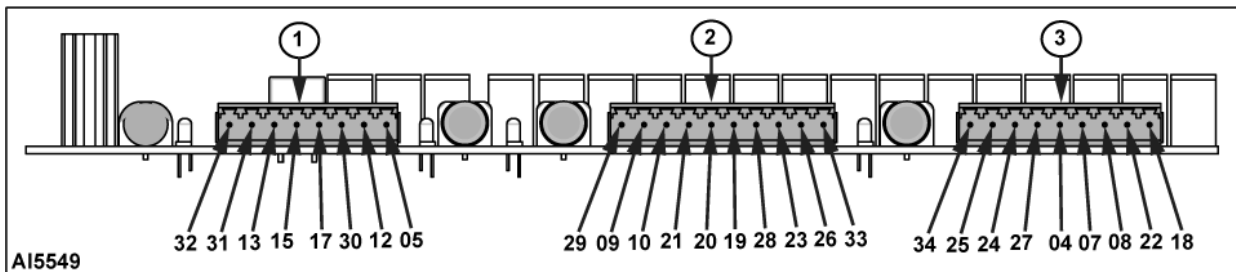

Fig. 136

Number	Connection	Function
1	32	N/A to unit.
	31	N/A to unit.
	13	N/A to unit.
	15	N/A to unit.
	17	N/A to unit.

Number	Connection	Function
	30	N/A to unit.
	12	N/A to unit.
	05	N/A to unit.
2	29	N/A to unit.
	09	Supplies 230VAC fused power to 3 way solenoid spray hose valve (Yd).
	10	Supplies 230VAC fused power to 3 way solenoid drain water valve (Yv).
	21	N/A to unit.
	20	N/A to unit.
	19	N/A to unit.
	28	N/A to unit.
	23	N/A to unit.
	26	N/A to unit.
	33	N/A to unit.
3	34	Supplies neutral.
	25	Supplies 230VAC fused power to 3 way solenoid cold water valve (Yef).
	24	Supplies 230VAC fused power to single solenoid hot water valve (Yec).
	27	N/A to unit.
	04	Supplies 230VAC fused power to left technical fan motor (Mt1).
	07	Supplies 230VAC fused power to right technical fan motor (Mt2), high limit thermostats (Fc1, Fc2, Fc3), and main contactor (Kp).
	08	Supplies 230VAC fused power to left heating contactor (Kr1).
	22	Supplies 230VAC fused power to right (VPP28) / middle (VPP40) heating contactor (Kr2).
	18	Supplies 230VAC fused power to right heating contactor (Kr3).

COMPONENT LOCATION & FUNCTION - TOUCHSCREEN FASTPAD 2 - WIRE CALLOUTS

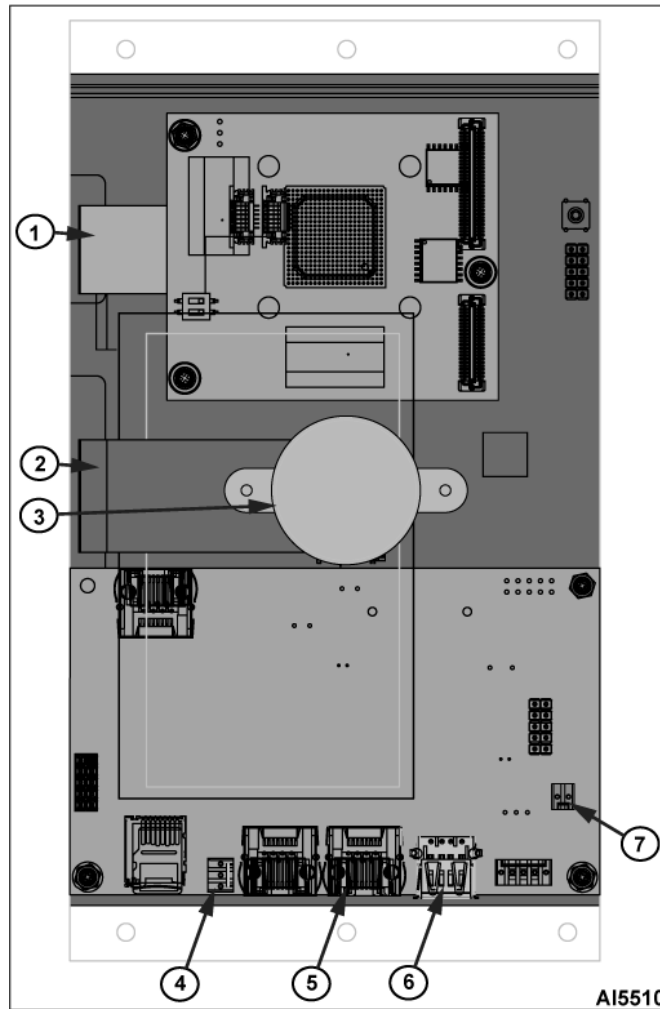

Fig. 137

Number	Name	Function
1	Touchscreen Ribbon	Connects touchscreen to Fastpad 2 board.
2	Display Ribbon	Connects display to Fastpad 2 board.
3	Buzzer	Connects buzzer to Fastpad 2 board.
4	Inter Card Cable	Plugs into Fastpad 2 board.
5	RJ45 Socket	Connects control input board to Fastpad 2 board.
6	USB Extension Cable	Connects USB port to Fastpad 2 board.
7	Buzzer Connection	Connects buzzer to Fastpad 2 board.

COMPONENT LOCATION & FUNCTION - CONTROL BOX

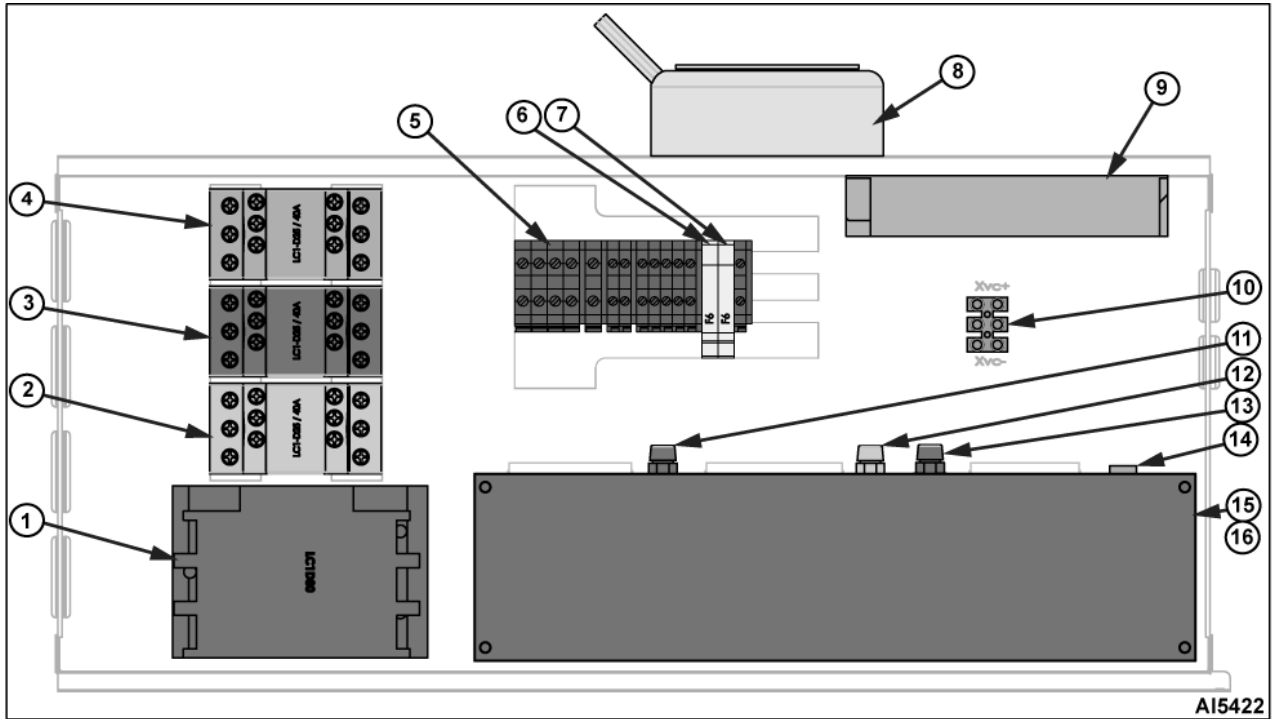

Fig. 138

Number	Component / Electrical Callout	Function
1	Main Contactor (Kp)	Controls voltage to (Kr1), (Kr2), (Kr3) line connections
2	Heating Contactor (left) (Kr1)	Energizes heating element (R3)
3	Heating Contactor (middle/ right) (Kr2)	Energizes heating element (R2)
4	Heating Contactor (right) (Kr3)	Energizes heating element (R1)
5	Terminal Block	Feeds 0VAC to transformer (TA).
6	Fuse (4A) (Ftc)	Protects the 230V line going to the transformer.
7	Fuse (4A) (Fta)	Protects the 24V circuit to the input power board.
8	Transformer (Tco) (415 VAC)	(On wire Xa) Provides 125V on (Xvb) and provides 0V on (Xb)
9	Switching Power Supply	Converts 230 VAC to 24 VDC to power components.
10	Terminal Block	Feeds tank ram motor.
11	Fuse (F5)	3.15A slow blow fuse. Provides over current protection for left technical fan motor (Mt1), right technical fan motor (Mt2), high limit thermostats (Fc1, Fc2, Fc3), left heating contactor (Kr1), and right / middle heating contactor (Kr2).
12	Fuse F1)	3.1A slow blow fuse. Provides over current protection for right heating contactor (Kr3), 3 way solenoid cold water valve (Yef) and single solenoid hot water valve (Yec).
13	Fuse (F2)	0.1A slow blow fuse. Not applicable with this unit.

Number	Component / Electrical Callout	Function
14	Fuse (F4)	0.2A slow blow fuse. Provides over current protection for 3 way solenoid drain water valve (Yv) and 3 way solenoid spray hose (Yd).
15	FastPad 2 Output Board (AR2)	Receives output from Control Board to enable/disable various functions of the machine.
16	FastPad 2 Input Board (AR1)	Controls operation of machine.

COMPONENT LOCATION & FUNCTION - LOWER PANEL

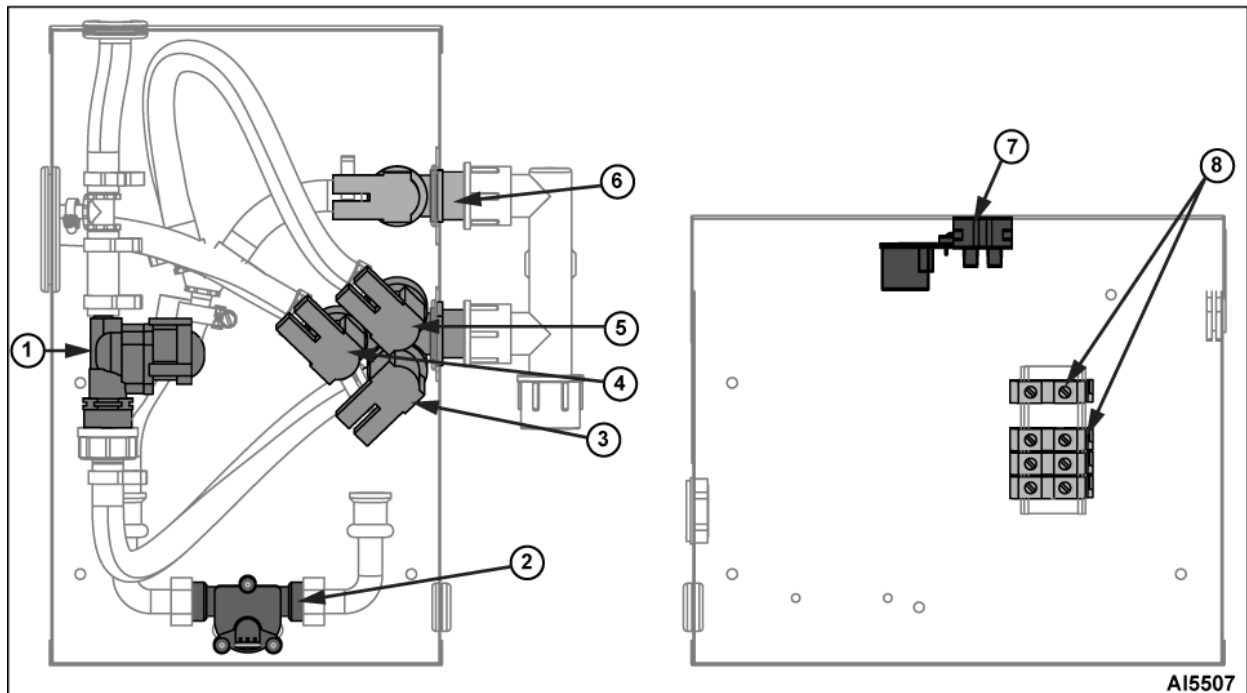

Fig. 139

Number	Component / Electrical Callout	Function
1	Pressure Regulator	Regulates water pressure to tank drain.
2	Flow Meter (Bd)	Measure flow of water in gals/liters during fill of tank.
3	3 Way Solenoid Valve	Yef Provides cold water to the tank.
4		Yd Provides water to spray hose.
5		Yv Provides water pressure to open drain valve body and condensate water to drain box simultaneously. (Only line regulated.)
6	Single Solenoid Valve (Yec)	Provides hot/cold water to the tank.
7	Supply Filter	Cleans noise from electrical supply.
8	Supply Terminal (Xa)	Supplies supplier line voltage to transformer (Tco) main contactor (Kp) and supply filter (Za.)

COMPONENT LOCATION & FUNCTION (VPP-28)

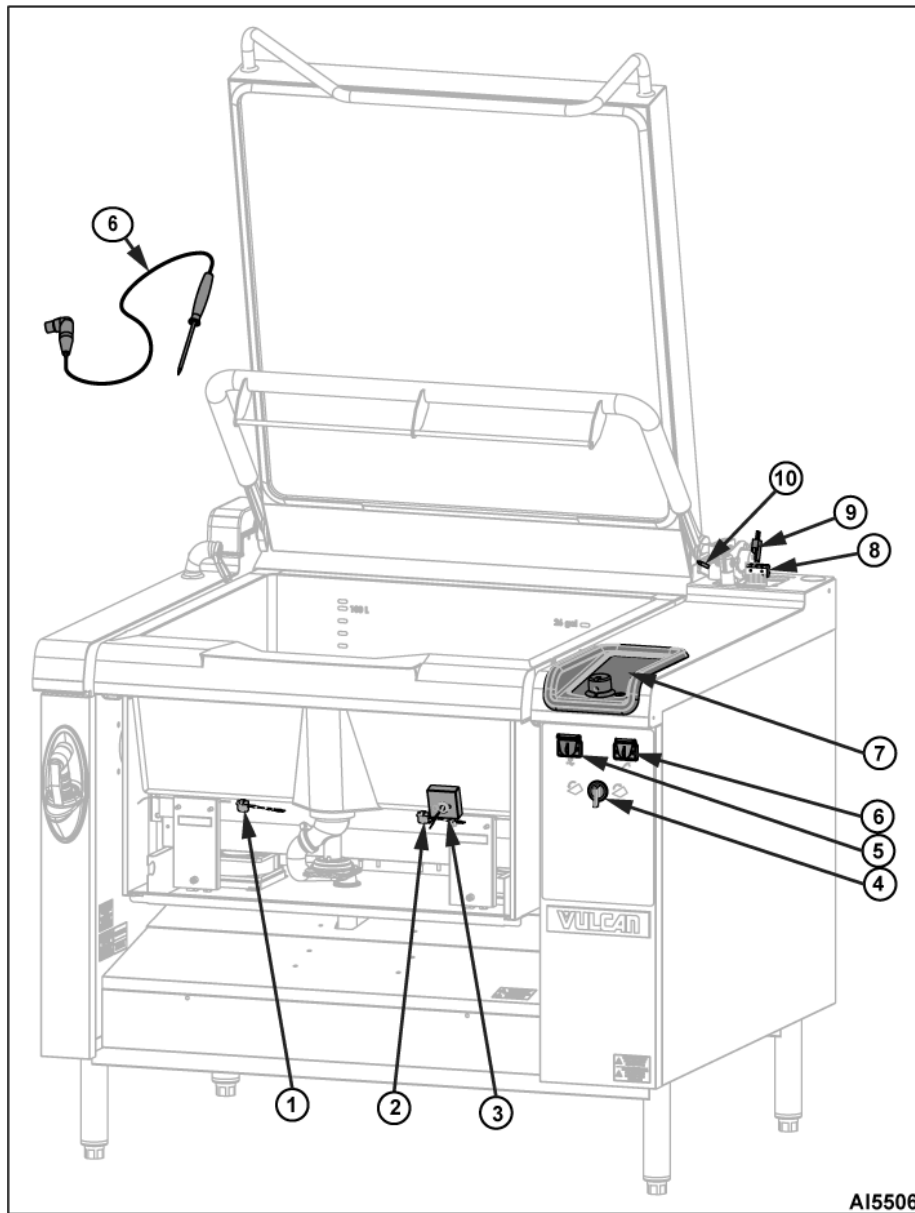

Fig. 140

Right Side (Shown From Front)		
Number	Component / Electrical Callout	Function
1	Left Temperature Tank Base Probe (Bf1)	Measures temperature of tank base on left side.
2	Right Temperature Tank Base Probe (Bf3)	Measures temperature of tank base on right side.
3	Tank Temperature Base (Well) Probe (BSb)	Measures temperature in tank.
4	Snap Action Switching (Scd / Scm)	Raises / lowers kettle.

Right Side (Shown From Front)		
Number	Component / Electrical Callout	Function
5	USB Port	Import / export of machine data, recipes, profiles along with software update.
6	Core Temperature Probe Port	External probe for measuring the internal temperature of product in pan.
7	FastPad2 Touchscreen / Display Assembly (Af)	Operator interaction for programming unit.
8	Terminal Block (Xd1, Xd2, Xd3, Xd4)	Connects basket lift arm switch and lid position switch to input power board.
9	Lid Position Switch (Scv)	Normally closed when lid is open. Sends signal to input power board.
10	Basket Lift Ram Detection Switch (Sbr)	Detects position of basket lift arm.

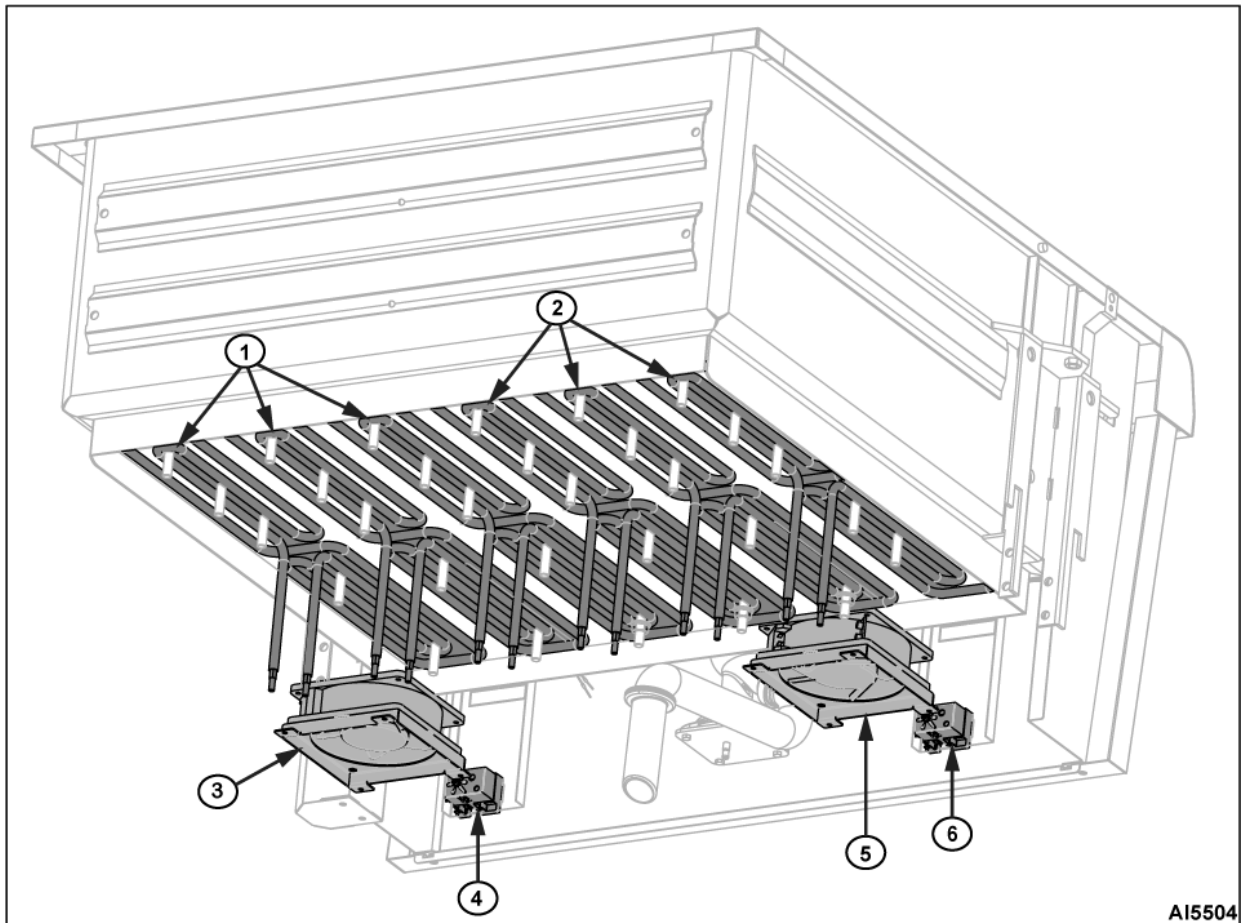

Fig. 141

Left Side (Shown From Back)		
Number	Component / Electrical Callout	Function
1	Right Heating Elements (R2)	Provides heat to right side of tank.

Left Side (Shown From Back)		
Number	Component / Electrical Callout	Function
2	Left Heating Elements (R1)	Provides heat to left side tank.
3	Right Technical Fan (Mt2)	Cools heating element wires.
4	Right High Limit Thermostat (Fc2)	Protects the main contactor by measuring maximum heat of 608°F on right side of tank.
5	Left Technical Fan (Mt1)	Cools heating element wires.
6	Left High Limit Thermostat (Fc1)	Protects the main contactor by measuring maximum heat of 608°F on left side of tank.

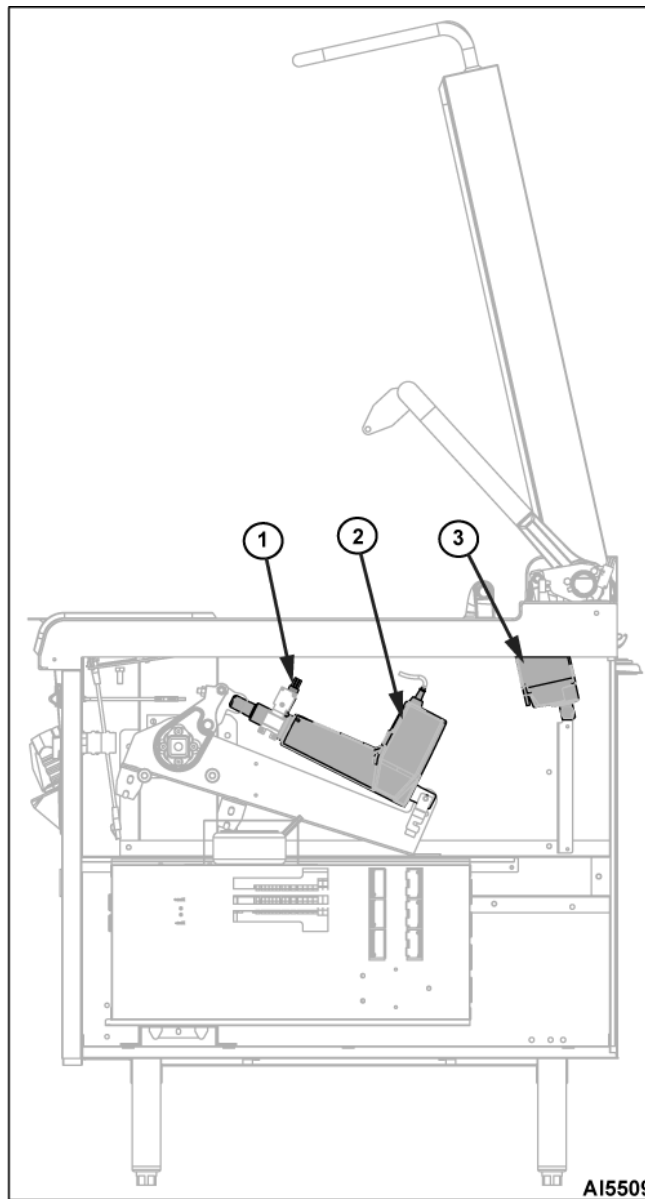

Fig. 142

Right Side		
Number	Component / Electrical Callout	Function
1	Tank Position Micro Ram Switch (Scu)	Operates closed when tank is in lowest position. Sends signal to input power board.
2	Tank Ram Motor (Vc)	Raises and lowers tank.
3	Lift Arm Basket Ram Motor (Vp)	Raises and lowers basket lift.

COMPONENT LOCATION & FUNCTION (VPP-40)

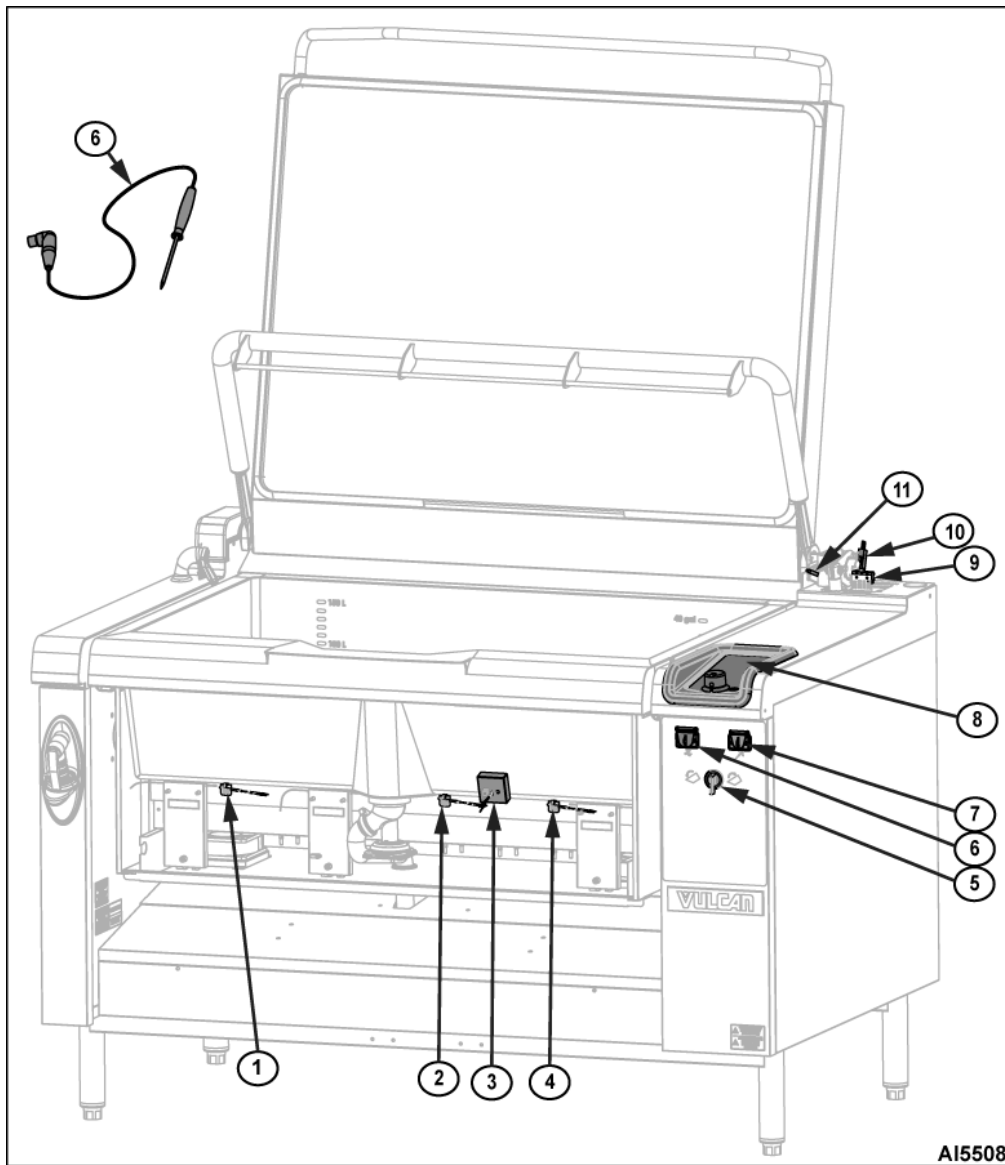

Fig. 143

Front Right Side		
Number	Component / Electrical Callout	Function
1	Left Temperature Tank Base Probe (Bf1)	Measures temperature of tank base on left side.
2	Middle Temperature Tank Base Probe (Bf2)	Measures temperature of tank base on right/middle.
3	Tank Temperature Base (Well) Probe (BSb)	Measures temperature in tank.
4	Right Tank Base Probe (Bf3)	Measures temperature of tank bank on right side.
5	Snap Action Switching (Scd / Scm)	Raises / lowers kettle.
6	USB Port	Import / export of machine data, recipes, profiles along with software update.
7	Core Temperature Probe Port	External probe for measuring the internal temperature of product in pan.
8	FastPad 2 Touchscreen / Display Assembly (Af) Control Panel	Operator interaction for programming unit.
9	Terminal Block (Xd1, Xd2, Xd3, Xd4)	Connects basket lift arm switch and lid position switch to input power board.
10	Lid Position Switch (Scv)	Normally closed when lid is open. Sends signal to input power board.
11	Basket Lift Ram Detection Switch (Sbr)	Detects position of basket lift arm.

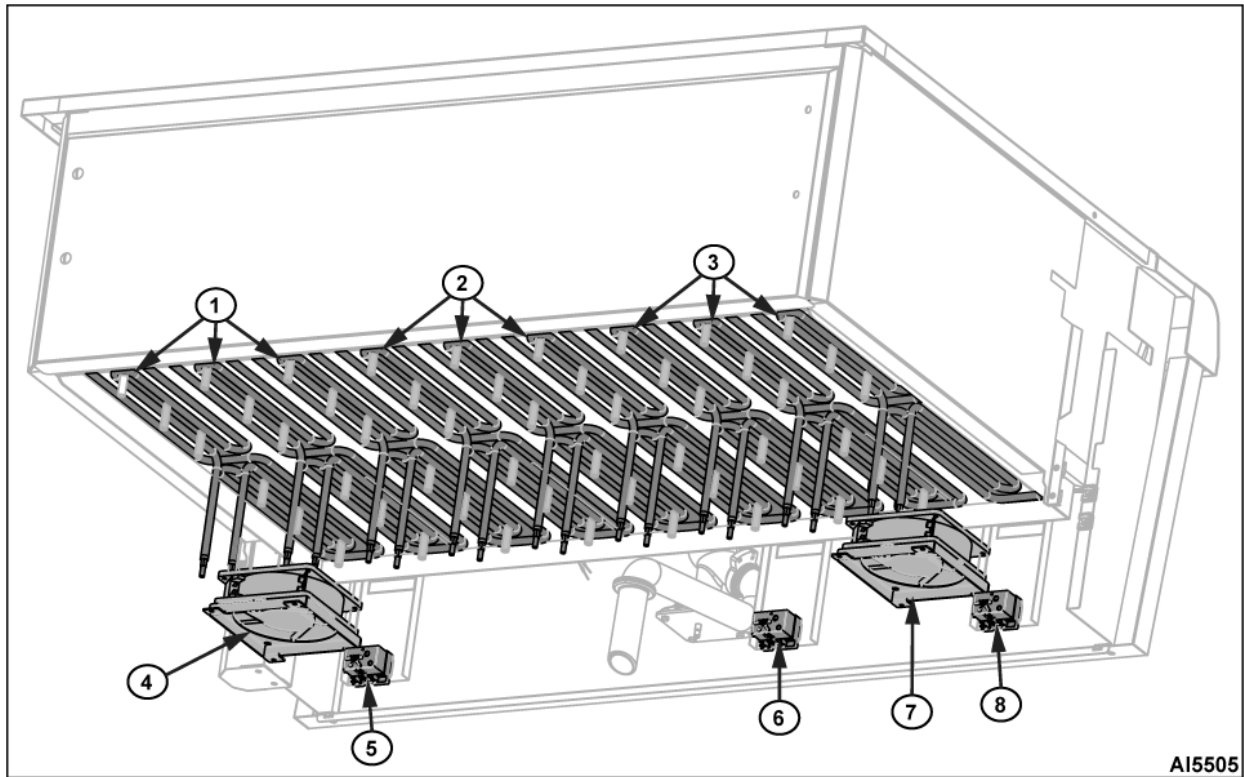

Fig. 144

AI5505

Back Side (Shown from Left)		
Number	Component / Electrical Callout	Function
1	Right Heating Elements (R3)	Provides heat to right side of tank.
2	Middle Heating Elements (R2)	Provides heat to middle of tank.
3	Left Heating Elements (R1)	Provides heat to left side tank.
4	Right Technical Fan (Mt2)	Cools heating element wires.
5	Right High Limit Thermostat (Fc3)	Protects the main contactor by measuring maximum heat of 608 on left side of tank.
6	Middle High Limit Thermostat (Fc2)	Protects the main contactor by measuring maximum heat of 608 on middle side of tank.
7	Left Technical Fan (Mt1)	Cools heating element wires.
8	Left High Limit Thermostat (Fc1)	Protects the main contactor by measuring maximum heat of 608 on left side of tank.

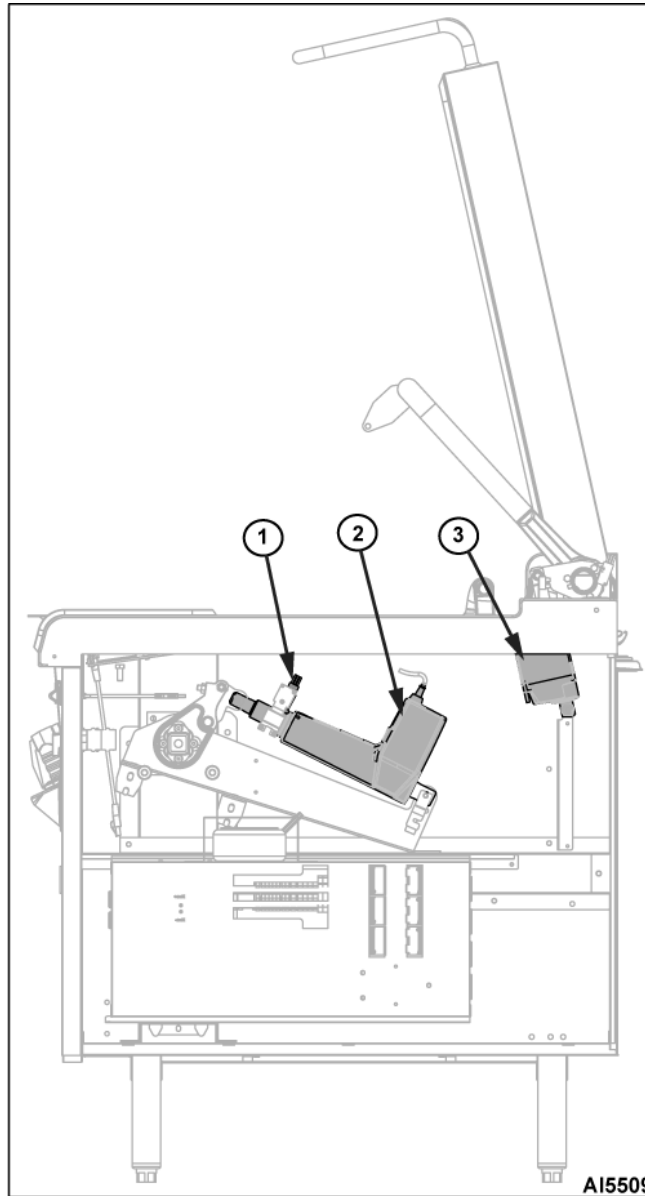

Fig. 145

Right Side		
Number	Component / Electrical Callout	Function
1	Tank Position Ram Switch (Scu)	Operates closed when tank is in lowest position. Sends signal to input power board.
2	Tank Ram Motor (Vc)	Raises and lowers tank.
3	Lift Arm Basket Ram Motor (Vp)	Raises and lowers basket lift.

7. SEQUENCE OF OPERATION

POWER APPLIED

1. Braising pan connected to correct supply voltage and is properly grounded.
 - A. Voltage supplied to line filters and to the terminal block in the power supply box.
 - B. Transformer (Tco) energized.
 - C. Transformer (Xa) 230v wire (bk7) supplies voltage through fuse 4A (Ftco), wire (Xb) provides 0v.
 - D. Switching power supply (Ta) is energized by wire (Xa) and wire (Xb) and supplies 24VDC through fuse 4A (Fta) to power input board (Ar1).
 - E. Supply voltage is applied to L1, L2 and L3 of main contactor (Kp).
 - F. Power input board (Ar1) supplies 24VDC to:
 - 1) Push button (coder)
 - 2) Wire 34 and 13 Snap action switch (Scm)
 - 3) Wire 44 and 23 Snap action switch (Scd)
 - 4) Brown wire to lift arm basket ram motor (Vp)
 - 5) Tank ram micro ram switch (Scu)
 - 6) Wire (Xd1) basket lift ram detection switch (Sbr)
 - 7) Wire (Xd3) lid position switch (Scv)
 - 8) FastPad 2 touch screen card (Af)
 - a. The control panel diagnostic light is red, small flashing yellow LED next to red indicator light.

POWER APPLIED, UNIT TURNED ON

1. Coder pressed.
2. 24VDC is supplied to input power board.
 - A. FastPad 2 touch screen illuminates.

NOTE: Speaker beeps when coder is pressed and touchscreen is touched.

NOTE: Touchscreen must be touched with fingerprint, not tip.

- 1) Loading bar appears on display, main contactor (Kp) energizes during loading.
- 2) Once loading bar is complete, operator display appears.
- B. The kettle is in flat position, 24VDC passes through tank position micro ram switch (Scu) from power input board (Ar1).
- C. Power input power (Ar1) reads the resistance of tank temperature base probes Left (Bf1), right (VPP28) / middle (VPP40) (BF2), right (VPP40) (Bf3), and tank temperature base probe (B Bb).
- D. 230V is applied to high limit manual resetting thermostats left (Fc1), right (VPP28) / middle (VPP40) (Fc2), and right (Fc3).
 - 1) Main contactor coil (Kp-A1) of main contactor (Kp) is energized.
- E. Once loading bar is complete.
 - 1) Main contactor (Kp) remains energized.
 - 2) 230V is supplied to coils left heating contactor (Kr1-A1), and right heating contactor (VPP28) / middle heating contactor (VPP40) (Kr2-A1), and right heating contactor (Kr3-A1) (VPP40) from power output board (Ar2).
 - 3) Left and right / middle heating contactors (Kr1) and (Kr2) energize right heating contactor (Kr3-A1) (VPP40).
 - 4) Left heating contactor (Kr1) supplies voltage to left heating elements (R1).
 - 5) Right (VPP28) / middle (VPP40) heating contactor (Kr2) supplies voltage to right / middle heating elements (R2).
 - 6) Right heating contactor (VPP40) (Kr3) supplies voltage to right heating elements (R3).
 - 7) Technical fans left (Mt1) and right (Mt2) are energized.

NOTE: Preheating can be stopped by pressing stop symbol on FastPad 2 touch screen.

- F. Unit continues to heat until it reaches set point based on resistance of tank temperature base probe.

NOTE: See chart for temperature probe readings.

- G. Water flows through solenoids, through flow meter (Bd) at front of water control box.
 - 1) If water is not sensed, error "i41 - no water detection" will appear. Refer to ERROR AND INFORMATION CODES.

DRAINING

1. Verify water is supplied to unit.
2. Drain tank initiated.
3. Drain solenoid (Yv) has 230V at coil.
4. Water pressure is supplied to small black hose on bottom of drain valve, hydraulically opening drain.
5. Water in tank drains down large tubing under tank near center of unit.
6. Drain solenoid (Yv) also supplies condensation cold water to drain box.

BASKET LIFT

1. Basket lift initiated from FastPad 2 touch screen.
2. Input Board energizes lift arm basket ram motor (Vp) 28VDC.
3. Input power board (Ar1) checks for lid position.
4. Lid position switch node is (Scv)
5. Basket lift ram detection switch is (Sbr).
6. Lift arm basket ram motor (Vp) raises and lowers basket lift based on option chosen.

8. DIAGRAMS

SCHEMATIC / WIRING DIAGRAM

Precipan V1 - 208-240V-60Hz-3Ph

[Precipan V1 - 208-240V-60Hz-3Ph - AI5501](#)

Precipan V1 - 480V-60Hz-3Ph

[Precipan V1 - 480V-60Hz-3Ph - AI5502](#)

Precipan V1 - 208-240-480V-60Hz-3Ph - Power Input Board (DC Voltage)

[Precipan V1 - 208-240-480V-60Hz-3Ph - AI5503](#)

Precipan V1 - 208-240-480V-60Hz-3Ph - Power Output Board (AC Voltage)

[Precipan V1 - 208-240-480V-60Hz-3Ph - AI5504](#)

Precipan V1 - 208-240-480V-60Hz-3Ph

[Precipan V1 - 208-240V-60Hz-3Ph - AI5665](#)

WATER (HYDRAULIC) DIAGRAM

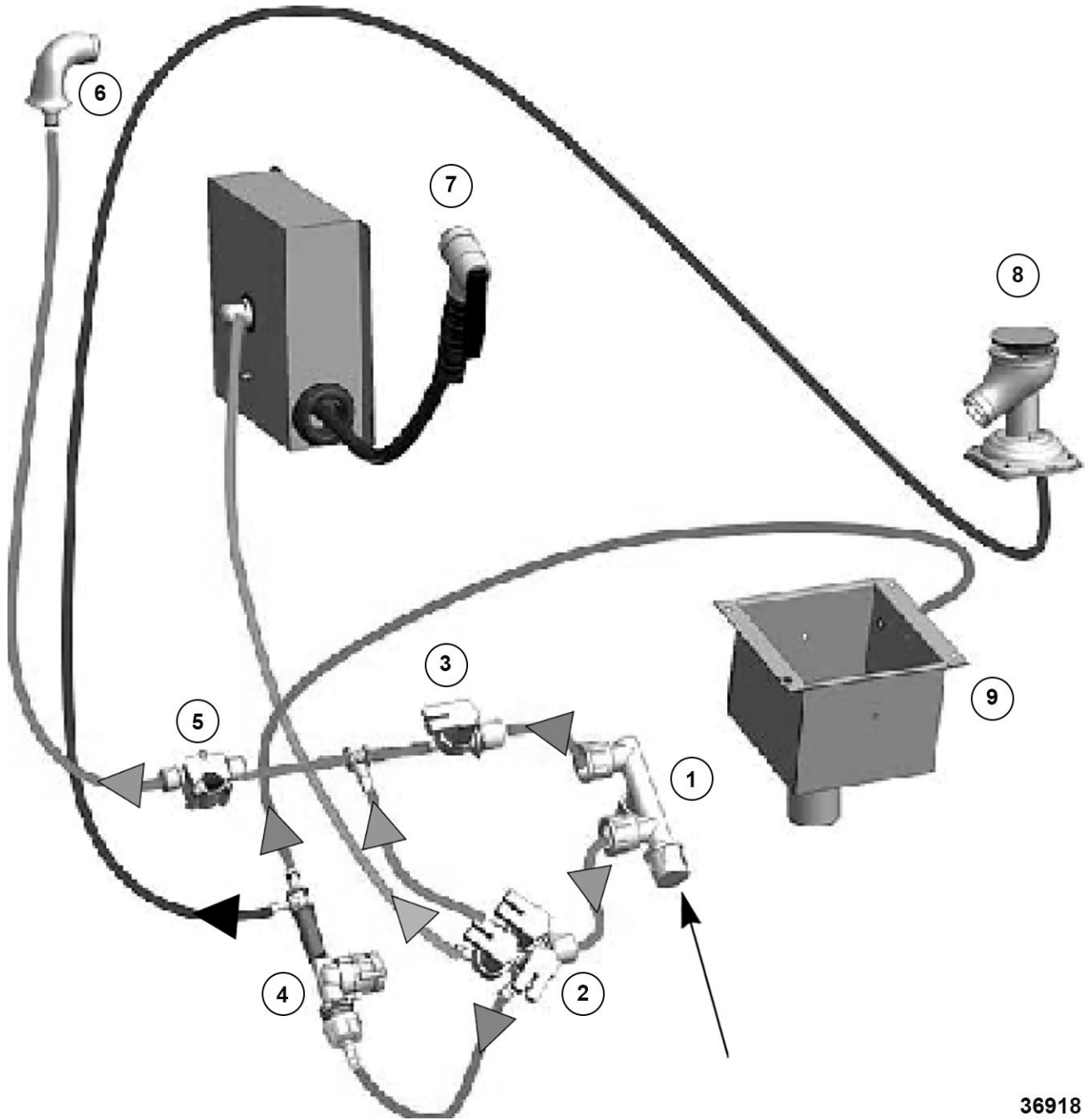

Fig. 146

36918

Flow Restrictors	100 Liters Electric	150 Liters Electric	26.5 Gallons Electric	39.5 Gallons Electric
Drain (L1)	0.5 L / Min	0.5 L / Min	0.10 Gals / Min	0.10 Gals / Min

Number	Component / Electrical Callout	Function
1	Water Supply Manifold (Cold Water Supply)	Supplies water to unit.

Number	Component / Electrical Callout	Function
2	3-Way Solenoid (Yef)	Provides cold water to tank.
	3-Way Solenoid (Yd)	Provides water to spray hose.
	3-Way Solenoid (Yv)	Provides water pressure to drain valve body and condensate water to drain box simultaneously. (Only line regulated.)
3	Single Solenoid (Yec)	Provides hot / cold water to tank..
4	Pressure Regulator	Regulates water pressure.
5	Flow Meter (Md)	Measures flow of water in gals/ liters during fill of tank.
6	Water Inlet	Sprays water into tank.
7	Spray Hose	Spray Hose
8	Drain Valve Body	Allows tank to drain.
9	Drain Box	Drain reservoir.

9. TROUBLESHOOTING

DIAGNOSTICS

The state of LEDs represents the communication between 2 electronic cards and helps with diagnostics in the event of a breakdown.







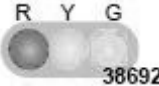
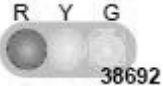
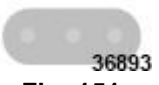
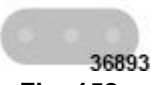

LED	LED Color	Status	Description
 Fig. 147	Red	Power On	LED Steady
	Yellow / Orange	Emitting	LED Steady or Flashing
	Green	Receiving	

NOTE: A flashing LED is considered active as is a steady one.



Fig. 148

FastPad Screen Card	FastPad 2 Power Assembly	Diagnostics	Actions
 Fig. 149	 Fig. 150	<ul style="list-style-type: none"> - FastPad 2 power assembly OK. - FastPad screen OK 	<ul style="list-style-type: none"> - Everything works normally
 Fig. 151	 Fig. 152	<ul style="list-style-type: none"> - Supply failure 	<ul style="list-style-type: none"> - Check power between terminals 1 and 3 on FastPad power assembly

FastPad Screen Card	FastPad 2 Power Assembly	Diagnostics	Actions
 <p>Fig. 153</p>	 <p>Fig. 154</p>	- Communication problem with FastPad screen card	- Replace FastPad screen card and / or interconnecting cable
 <p>Fig. 155</p>	 <p>Fig. 156</p>	- FastPad 2 C power card defective	- Replace FastPad 2 power assembly
 <p>Fig. 157</p>	 <p>Fig. 158</p>	- Screen not working	- Replace FastPad screen card
 <p>Fig. 159</p>	 <p>Fig. 160</p>	- Cable linking FastPad screen to FastPad 2 power assembly	- Replace link cable between cards

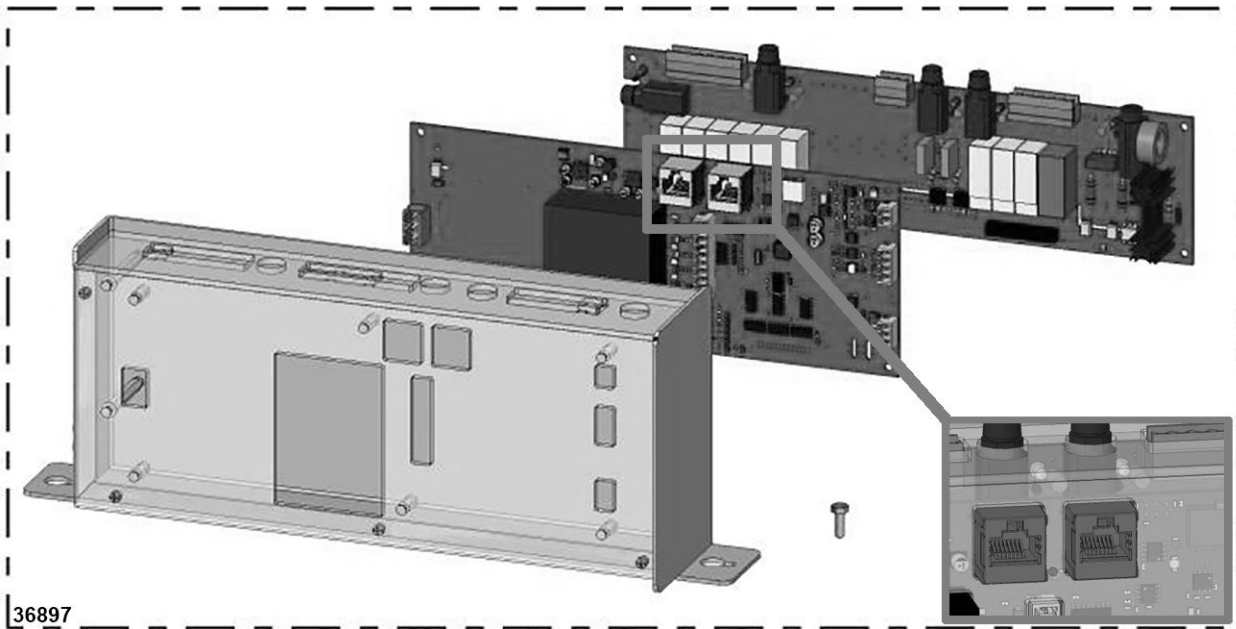

Fig. 161

**MAINTENANCE /
TROUBLESHOOTING SCREENS**

1. Select "TOOL BOX" option to enter screen.



Fig. 162

2. Select "Technical parameters" option.



Fig. 163

3. Enter password "SAVB".

NOTE: Password is not case sensitive.



Fig. 164

4. Select checkmark "☑" to enter.

NOTE: If code is entered correctly the menu screen will display. Otherwise, re-enter pin.



Fig. 165



Fig. 167

5. Press "Next" button to scroll through different screens.

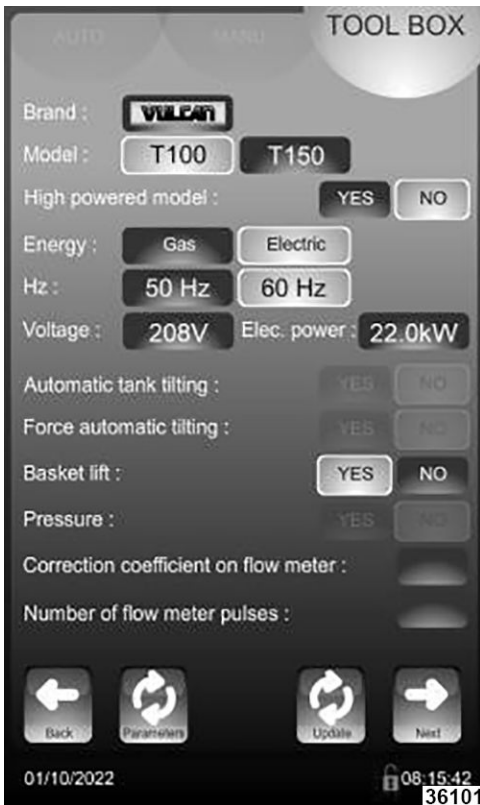
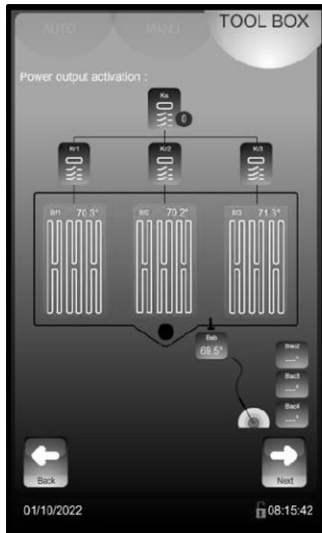

Fig. 166

SCREEN: ACTIVATION OF THE POWER OUTPUTS (SCHEMATIC)



- Activation of the safety contactor Ks. (One press = 15s)
- Activation of each individual heating element (One press = 15 seconds of operation)
- Visualisation of the tank base temperature probes
- Visualisation of the tank temperature probe
- Visualisation of the core probe temperature

Fig. 168

36105

SCREEN: HYDRAULIC CIRCUIT (SCHEMATIC)

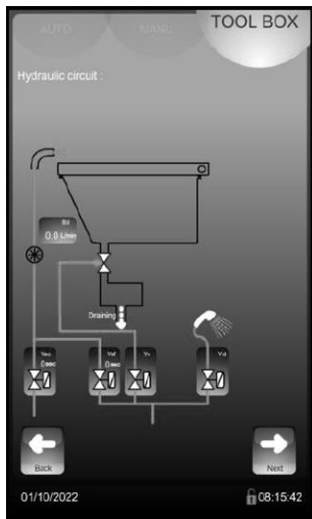

- Flow meter: visualisation of flow when solenoids are activated
- Activation of the solenoids: A press on each touch button allows the solenoid to operate (the time of activation is displayed in seconds)
 Yv and Yd: one press = 10 seconds of operation
 Yec and Yef: one press = 1 minute of operation

Fig. 169

36106

SCREEN: TILT AND LIFT

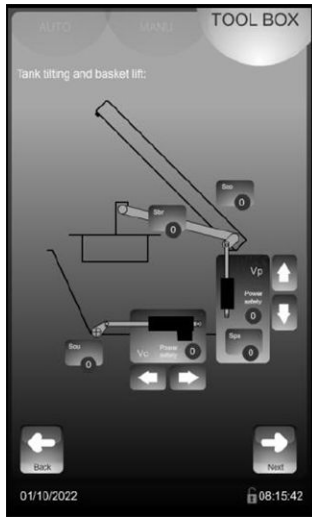

- Lid opening sensor (1 : lid open ; 0 : lid closed)
- Basket lift:
 - lift arm presence detector (1 : yes ; 0 : no)
 - Basket lift ram: manual ram control and ram status
- Tank tilt:
 - Tank base ram detector (1 : tank lowered ; 0 : tank tilted)
 - Tank tilt ram: manual ram control and ram status
 Turn the button on the facia to activate the tank tilting jack. (The arrows on the screen are not active for this appliance model)

36107

Fig. 170

ERROR AND INFORMATION CODES

Information Code Screens: ixx		Error Code Screen: Exx
Green screen: Information on cooking	Red screen: Cooking stopped (pause)	Red screen: Cooking stopped (pause)
<p style="text-align: right;">36074</p>	<p style="text-align: right;">36075</p>	<p style="text-align: right;">36076</p>
Fig. 171	Fig. 172	Fig. 173
Non-blocking message Touching screen anywhere will clear message	Blocking message Cooking stops	Blocking message Cooking stops

Information Codes			
Code	Symptom	Possible Cause	Possible Solution
i28	Cooking doesn't start.	Core Probe: Faulty or missing	
		Core probe absent at the start of a cooking cycle.	Plug in a functioning probe or switch to timer mode or check the probe connection.
		Core probe faulty.	Connect probe and check on the entries screen the values of Bsc2 – Bsc3 and Bsc4. Si "---", Disconnect the connection (Bsc) from the card. Check PT 100 probe reading (on the connection screws) If the value is incorrect change the probe. If not check the connection or replace the (power assembly) input / output boards.
i33	Cooking stops.	Core probe : faulty or disconnected during cooking	
		Core probe disconnected during a cooking cycle.	Plug in a functioning probe or switch to timer mode or check the probe connection.
		Core probe faulty.	Connect probe and check on the entries screen the values of Bsc2 – Bsc3 and Bsc4. Si "---", Disconnect the connection (Bsc) from the card. Check PT 100 probe reading on the connection screws. If the value is incorrect change the probe. If not check the connection or replace the (power assembly) input / output boards.
i41	Cooking continues.	Lack of water detected, water is not flowing from the spout	
		Water supply turned off.	Turn the water on.
		The water inlet filter is blocked.	The required water pressure is present at the inlet. The solenoid is correctly supplied. Clean the water inlet filter.
		The coil of one of the solenoids Yef or Yec has failed or is short circuit. F1 is open.	Check solenoid's coil. Change the defective solenoid. Change the fuse.
		One of the solenoids coil is cut.	Check that there is power to the solenoid. Check the continuity of the coil with a multi tester. Change the solenoid.

Information Codes			
Code	Symptom	Possible Cause	Possible Solution
		The solenoid control relay is not closing	There is no power between S24 (or S25) on the relay bar and neutral. Change the relay bar.
		Flow meter non function.	Check the value read by the flow meter in entry status (technician's parameters). Replace if necessary.
	USB stick missing or full		
i49		USB stick not detected or not connected.	Plug in a USB stick. NOTE: If the message persists, change the USB stick.
		USB stick full.	Empty the USB stick or replace it.
	Number of maintenance days at 0		
i84	Risk of damaging oven.	The countdown to the next service has been reached and exceeded.	Carry out the planned preventative maintenance operations (see paragraph 7) then reset the counter in the installation parameters (§ 7.3).
	Connectivity error		
i97	Connectivity not working.	Identification data incorrect (the data contained in the GATEWAY configuration doesn't match the data on the screen).	If the GATEWAY was previously configured on another oven: follow the GATEWAY configuration procedure and scan the QR code which corresponds to the oven. If the screen has been changed and it is necessary to fill in the appliance's technical data.
	Connectivity error		
i98	No consequence.	Connected appliance: technical parameters cannot be changed.	The Pop-Up will simply inform the technician why they cannot change the parameters.

Error Code			
Code	Symptom	Possible Cause	Possible Solution
E32	Core Probe: 2 sensors are not working		
	Cooking continues.	Core probe faulty (More than one sensor working).	Connect probe and check on the entries screen the values of Bsc2 – Bsc3 and Bsc4. Si "---", Disconnect the connection (Bsc) from the card. Check PT 100 probe reading (on the connection screws). If the value is incorrect change the probe. If not check the connection or replace the (power assembly) input / output boards.
E30	Electronics overheated (> 158°F (70°C))		
	Cooking continues.	Overheating of the technical area because the environment is too hot.	Installation problem: check heating appliances near to the right hand side of the unit.
E72	Electronics overheated (> 185°F (85°C))		
	Cooking stops.	Overheating of the technical area because the environment is too hot.	Installation problem: check heating appliances near to the right hand side of the unit.
ESx	Tank base probe short circuit or disconnected (X = Number of the heating zone 1 to 3)		
	Cooking stops.	Temperature probe poor connection (connection to relay card) or cut.	Check the temperature being read by the probe in the entries status (technician's parameters). Check the wires into Bf1, Bf2 or Bf3 are tight (power assembly) input / output boards.
Probe short circuit.		Check the temperature being read by the probe in the entries status (technician's parameters). Disconnect the connection (Bfx) from the card. Check the PT 100 probe reading on the connection screws. NOTE: If the value is incorrect change the probe. NOTE: If the probe is working replace the (power assembly) input / output boards.. Requires a restart to clear the fault.	

Error Code			
Code	Symptom	Possible Cause	Possible Solution
ESb	Tank probe short circuit or disconnected		
	Cooking stops.	Temperature probe poor connection (connection to relay card) or cut.	Check the temperature being read by the probe in the entries status (technician's parameters). Check the wires into Bsb are tight (power assembly) input / output boards.
Probe short circuit.		Check the temperature being read by the probe in the entries status (technician's parameters). Disconnect the connection (Bsb) from the card. Check the PT 100 probe reading on the connection screws. NOTE: If the value is incorrect change the probe. NOTE: If the probe is working replace the (power assembly) input / output boards. Requires a restart to clear the fault.	
EFr	Tank probe overheated		
	Cooking stops.	The tank probe is measuring a temperature > 401°F (205°C).	Check that one of the control contactors is not fused or that the corresponding output is not always active (fused relay). To restart the unit: Wait until the temperature is below 248°F (120°C) Switch off then restart the unit.
EFx	Tank base overheated (X = Number of the heating zone 1 to 3)		
	Cooking stops.	One of the tank base probes is measuring a temperature > 546.8°F (286°C).	Check that one of the control contactors is not fused or that the corresponding output is not always active (fused relay). To restart the unit: Wait until the temperature is below 248°F (120°C). Switch off then restart the unit.

Error Code			
Code	Symptom	Possible Cause	Possible Solution
ESA	Cooking stops.	Tank base probe fault	
		One of the tank base probes is reading a temperature > 563°F (295°C).	Check that one of the control contactors is not fused or that the corresponding output is not always active (fused relay). Requires a full restart to clear the fault.
		Temperature probe badly connected (to relay card) or cut.	Check the temperature being read by the probe on the entry status (technician's parameters). Check the wires are tight on connectors Bf1, Bf2 or Bf3 (power assembly) input / output boards.
		Probe short circuited.	Check the temperature being read by the probe on the entry status (technician's parameters). Disconnect the connection (Bfx) on the card. Check the value of the PT 100 probe on the connection strip. NOTE: If the reading is incorrect change the probe. NOTE: If the probe is correct replace the (power assembly) input / output boards. Requires a full restart to clear the fault.
E43	Cooking continues.	Leak detected	
		Solenoid failing.	Check solenoids Yef (S25) and Yec (S24) and replace if necessary.
		Flow meter non function.	Check the value read by the flow meter in entry status (technician's parameters). Replace if necessary.
		Supply relay to one of the solenoids is fused.	Check the voltage on the outputs S25 and S24. NOTE: If power present without water being demanded replace the relay bar on the (power assembly) input / output boards.

Error Code			
Code	Symptom	Possible Cause	Possible Solution
E90	Tank tilt ram blocked		
		The power consumption of the ram is > 6 A.	An object is trapped under the tank preventing its operation: Clear it out.
			Check the tank tilt system.
			Check the ram – Replace if necessary
E93	Safety contactor faulty		
	Cooking cycles will not start.	When the unit is started, the "E1" input on the power assembly is "open".	Check the continuity of the electrical circuit between the auxiliary contact "21 and 22" of Ks and E1 - Tighten the connections - Check the condition of the wires.
			Check the state of Ks – Change if necessary.
			Change the (power assembly) input / output boards.

PT100 PROBE CHECK

The PT100 probe resistance determines temperature. It has a resistance of 100 Ω at 32 °F (-0 °C) and 138.5 Ω at 212 °F (100 °C) . The sensor is linear and its connections are not polarized. See table below for temperature / resistance ratio.

Temperature in °F relative to Resistance in Ω for PT100 probe										
°F	0	1	2	3	4	5	6	7	8	9
30			100.00	100.22	100.43	100.65	100.87	101.08	101.30	101.52
40	101.73	101.95	102.17	102.39	102.60	102.82	103.04	103.25	103.47	103.69
50	103.90	104.12	104.33	104.55	104.77	104.98	105.20	105.42	105.63	105.85
60	106.06	106.28	106.50	106.71	106.93	107.14	107.36	107.58	107.79	108.01
70	108.22	108.44	108.66	108.87	109.09	109.30	109.52	109.73	109.95	110.16
80	110.38	110.60	110.81	111.03	111.24	111.46	111.67	111.89	112.10	112.32
90	112.53	112.75	112.96	113.18	113.39	113.61	113.82	114.04	114.25	114.47
100	114.68	114.90	115.11	115.33	115.54	115.75	115.97	116.18	116.40	116.61
110	116.83	117.04	117.26	117.47	117.68	117.90	118.11	118.33	118.54	118.75
120	118.97	119.18	119.40	119.61	119.82	120.04	120.25	120.47	120.68	120.89
130	121.11	121.32	121.53	121.75	121.96	122.17	122.39	122.60	122.81	123.03
140	123.24	123.45	123.67	123.88	124.09	124.31	124.52	124.73	124.94	125.16
150	125.37	125.58	125.80	126.01	126.22	126.44	126.65	126.86	127.07	127.29
160	127.50	127.71	127.92	128.14	128.35	128.56	128.77	128.99	129.20	129.41
170	129.62	129.84	130.05	130.26	130.47	130.68	130.90	131.11	131.32	131.53
180	131.74	131.96	132.17	132.38	132.59	132.80	133.01	133.23	133.44	133.65
190	133.86	134.07	134.28	134.49	134.71	134.92	135.13	135.34	135.55	135.76
200	135.97	136.18	136.40	136.61	136.82	137.03	137.24	137.45	137.66	137.87
210	138.08	138.29	138.50	138.72	138.93	139.14	139.35	139.56	139.77	139.98
220	140.19	140.40	140.61	140.82	141.03	141.24	141.45	141.66	141.87	142.08
230	142.29	142.50	142.71	142.92	143.13	143.34	143.55	143.76	143.97	144.18
240	144.39	144.60	144.81	145.02	145.23	145.44	145.65	145.86	146.07	146.28
250	146.49	146.70	146.90	147.11	147.32	147.53	147.74	147.95	148.16	148.37
260	148.58	148.79	149.00	149.20	149.41	149.62	149.83	150.04	150.25	150.46
270	150.67	150.87	151.08	151.29	151.50	151.71	151.92	152.13	152.33	152.54
280	152.75	152.96	153.17	153.38	153.58	153.79	154.00	154.21	154.42	154.62
290	154.83	155.04	155.25	155.46	155.66	155.87	156.08	156.29	156.49	156.70
300	156.91	157.12	157.32	157.53	157.74	157.95	158.15	158.36	158.57	158.78
310	158.98	159.19	159.40	159.60	159.81	160.02	160.23	160.43	160.64	160.85
320	161.05	161.26	161.47	161.67	161.88	162.09	162.29	162.50	162.71	162.91
330	163.12	163.33	163.53	163.74	163.95	164.15	164.36	164.56	164.77	164.98
340	165.18	165.39	165.60	165.80	166.01	166.21	166.42	166.63	166.83	167.04
350	167.24	167.45	167.65	167.86	168.07	168.27	168.48	168.68	168.89	169.09
360	169.30	169.50	169.71	169.92	170.12	170.33	170.53	170.74	170.94	171.15
370	171.35	171.56	171.76	171.97	172.17	172.38	172.58	172.79	172.99	173.20
380	173.40	173.61	173.81	174.01	174.22	174.42	174.63	174.83	175.04	175.24
390	175.45	175.65	175.86	176.06	176.26	176.47	176.67	176.88	177.08	177.28
400	177.49	177.69	177.90	178.10	178.30	178.51	178.71	178.92	179.12	179.32
410	179.53	179.73	179.93	180.14	180.34	180.54	180.75	180.95	181.15	181.36
420	181.56	181.76	181.97	182.17	182.37	182.58	182.78	182.98	183.19	183.39
430	183.59	183.80	184.00	184.20	184.41	184.61	184.81	185.01	185.21	185.42
440	185.62	185.82	186.03	186.23	186.43	186.63	186.83	187.04	187.24	187.44

32140

Fig. 174

MOTORIZED LIFT OPTION ONLY

SYMPTOMS	POSSIBLE CAUSES
Pan will not raise.	<ol style="list-style-type: none"> 1. Lid switch open (lid not opened) or malfunction. 2. 120/24VAC transformer inoperative. 3. On/off switch off or malfunction. 4. Lift control switch malfunction (momentary on - raise). 5. Up limit switch malfunction. 6. DC motor controller - Fuses open or controller malfunction. 7. DC Lift motor inoperative. 8. Interconnecting wiring malfunction.
Pan will not lower.	<ol style="list-style-type: none"> 1. Lid switch open (lid not opened) or malfunction. 2. 120/24VAC transformer inoperative. 3. On/off switch off or malfunction. 4. Lift control switch malfunction (momentary on - lower). 5. Down limit switch malfunction. 6. DC motor controller - Fuses open or controller malfunction. 7. DC Lift motor inoperative. 8. Interconnecting wiring malfunction.

TROUBLESHOOTING

Symptoms	Possible Cause
Unit powers on without pressing power button. Display comes on when power is applied without pressing power button.	<ol style="list-style-type: none"> 1. Check for loose connection at terminal block (L1).
Leak / gap between lid gasket and tank.	<ol style="list-style-type: none"> 1. Adjust tank ram position using hardware at the end of the tank ram.
Lower case i41 error code. (Refer to <u>ERROR AND INFORMATION CODES</u>)	<ol style="list-style-type: none"> 1. No water detection. 2. Check water supply. 3. Check voltage to the coils of the solenoids. 4. Check resistance of coil.
Not heating.	<ol style="list-style-type: none"> 1. Check resistance of temperature base probes (Bf1, Bf2, Bf3). 2. Check resistance of tank probe (B Sb) . 3. Check for voltage applied to main contactor coil (Kp) and contacts. 4. Check for voltage to Heating contactor coils and contacts (Kr1, Kr2, Kr3). 5. Check resistance of heating elements (R1, R2, R3). 6. Check for loose/broken wire to elements. 7. Verify manual resetting thermostats (Fc1, Fc2 and Fc3) are closed. Check fuse (F5).

Symptoms	Possible Cause
No power to Input Board.	<ol style="list-style-type: none"> 1. Check fuse (FTA). 2. Verify 24 vdc to power input board at E and V test points. 3. Check switching power supply board transformer (Ta) for incoming voltage and 24vds at + and -.
Tank Ram Vc not operating.	<ol style="list-style-type: none"> 1. Check voltage/continuity across contacts of Scm and Scd Snap action switch. 2. Check micro ram switch (Scu) is operating properly. 3. Check reed detector for lift arm (Sbr) is operating properly. 4. Check lid position switch (Scv) is operating properly. 5. Verify good connection at Xvc1 and Xcv2 connection points.
Touchscreen not functioning or powering on.	<p>NOTE: Performing procedure will set machine to factory reset. Machine will need to be reprogrammed after reset.</p> <ol style="list-style-type: none"> 1. Turn on power and within the first 8 seconds (indication lights showing), lower lid down approximately 40 degrees and lift up 6 times, activating reed switch, resetting to factory reset touchscreen system. <p>NOTE: Unit will beep multiple times informing user of reset.</p> <p>NOTE: All errors or issues preventing touchscreen from working will be removed, allowing touchscreen to work properly.</p>