

**O V E N S****VULCAN****VC3E SERIES  
SINGLE DECK ELECTRIC CONVECTION OVEN****Model VC3ED**

Shown with optional legs &amp; casters

**SPECIFICATIONS**

Single section, electric convection oven, Vulcan Model No. (VC3ED). Stainless steel front, sides and top. Painted legs. Independently operated removable stainless doors with double pane windows. Non-sag insulation applied to top, rear, sides, bottom. Porcelain enamel on steel oven interior measures 29" w x 22 $\frac{1}{8}$ " d x 20" h. One interior oven light. Five nickel plated oven racks measure 28 $\frac{1}{4}$ " x 20 $\frac{1}{2}$ ". Eleven position nickel plated rack guides with positive rack stops. Heated by electric solid sheath elements rated at 12.0 KW. Furnished with a two speed  $\frac{1}{2}$  H.P. oven blower motor. Oven cool switch for rapid cool down. 208/240V 60Hz 1 or 3 phase.

**Exterior Dimensions:**40" w x 40 $\frac{1}{8}$ " d (includes motor & door handles)

37" d (includes motor only)

54" h on 23 $\frac{3}{4}$ " legs (add 2" if on casters)**STANDARD FEATURES**

- Solid state temperature controls from 150° to 500°F.
- 60 minute timer with audible alarm.
- Stainless steel front, sides and top.
- Painted legs.
- Independently operated removable stainless steel doors with double pane windows.
- 12.5 total KW.
- $\frac{1}{2}$  H.P. two speed oven blower-motor.
- Moisture vent.
- Oven cool switch for rapid cool down.
- Porcelain enamel on steel oven interior.
- Five nickel plated oven racks with eleven rack positions.
- One year limited parts and labor warranty.
- Three year limited warranty on doors.

**OPTIONS**

- Stainless steel legs.
- Casters.
- 480V/60 Hz/1 or 3 phase.
- Second year extended limited parts and labor warranty.

**ACCESSORIES**

- Stainless steel rear motor enclosure.
- Extra oven rack(s).
- Rack hanger(s).
- Stainless steel drip pan.
- Stainless steel open stand with adjustable rack supports, stainless steel shelf and choice of adjustable feet or casters.
- Down draft flue diverter for direct vent connection.
- Heat shields for oven sides.

**VULCAN**

a division of ITW Food Equipment Group LLC

P.O. Box 696 ■ Louisville, KY 40201 ■ Toll-free: 1-800-814-2028 ■ Local: 502-778-2791 ■ Quote &amp; Order Fax: 1-800-444-0602



**VC3E SERIES**  
SINGLE DECK ELECTRIC CONVECTION OVEN

**OPTIONAL VOLTAGES**

480 volt, 60 Hz, 3 phase.

**CLEARANCES**

	Combustible	Non-Combustible
Rear	2"	2"
Right Side	4"	4"
Left Side	1"	1"

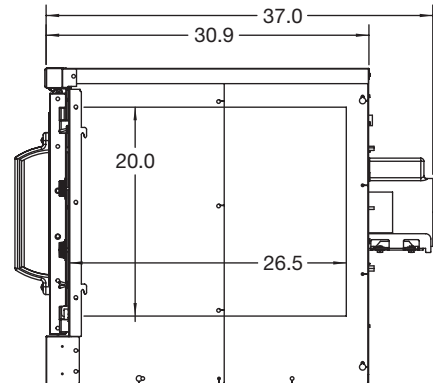
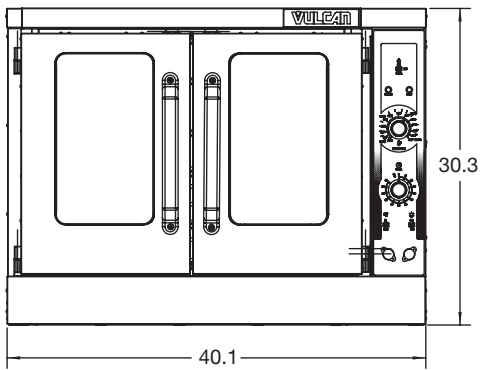
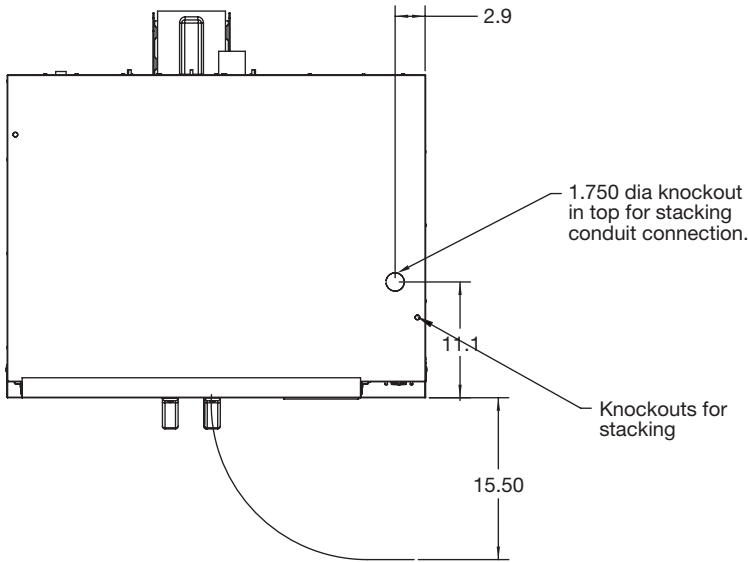

MODEL NO.	TOTAL CONN. KW	3 PHASE LOAD KW PER PHASE			NOMINAL AMPS PER LINE WIRE									WEIGHT					
					3 PHASE									1 PHASE		WITH SKID & PACKAGING		WITHOUT SKID & PACKAGING	
					208 VOLT			240 VOLT			480 VOLT								
		X-Y	Y-Z	X-Z	X	Y	Z	X	Y	Z	X	Y	Z	208V	240V	LBS.	KG	LBS.	KG
<b>VC3E</b>	12.5	4	4	4.5	35	33	35	33	29	33	14	15	15	60	52	337	153	286	130



a division of ITW Food Equipment Group LLC

P.O. Box 696 ■ Louisville, KY 40201 ■ Toll-free: 1-800-814-2028 ■ Local: 502-778-2791 ■ Quote & Order Fax: 1-800-444-0602

**NOTE:** In line with its policy to continually improve its products, Vulcan reserves the right to change materials and specifications without notice.