



C24EA3 & C24EA5 STEAMERS
Operator's Startup, Shutdown, & Routine
Inspection Checklist



BEFORE DAILY OPERATION

- Check to make sure main water supply is turned on.
- Verify unit is plugged in and power is turned on to the unit.
- Set timer for 5 minutes.
- Turn the unit on with the power switch, power light will illuminate. Unit will fill with water.
- Close the door and in approximately 10 minutes the buzzer will sound indicating the unit is preheated and ready to cook.

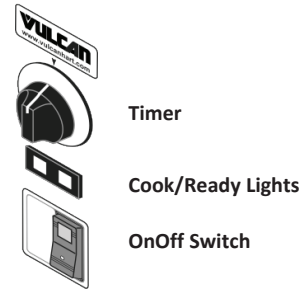

AFTER DAILY USE

- Prior to cleaning close the door and set timers to 5 minutes. This will loosen any stuck foods in the cooking compartment.
- Turn unit off using main power switch. Do not remove power from unit for 5 minutes to allow unit to completely drain. (Note: Some hood systems remove power from steamer when turned off.)

DAILY CLEANING

- Thoroughly clean the unit with mild soap and water and dry. Do not use cleaners containing chlorides or chlorine.
- Thoroughly clean cavity drain screens. Clogged drain screens can effect cooking performance, cause door leaks, and damage the unit.
- Leave doors open after cleaning to allow cavity and door seal to air dry.

EXTENDED SHUT DOWN

- It is recommended to perform delime on the steamer if it has not been done recently. Always replace filter(s) when the steamer is brought back into service.
- Perform daily shut down and cleaning.
- After unit has completely drained disconnect power from unit.
- Shut off main water supply.

PERIODIC MAINTENANCE

- Delime generator weekly if no water treatment other than a carbon block is being used. 14 Oz of ScaleRelease is required. ScaleRelease P/N 854893-13 (14 oz).
- Change carbon block filter every 6 months or per filter manufacture's recommendation.
- Weekly inspect door seals for cuts, tears, or leaks. Replace as needed.
- Weekly check filter system pressure, 20PSI minimum / 60PSI Maximum while filling. Change cartridge(s) if pressure is low or if they are due for replacement.
- If ScaleBlocker® SMF600 water treatment system is used the preventative maintenance must be performed every 6 months. (Kit P/N 857487-00600) Additional deliming may be needed, see chart at right. Use ScaleRelease (14 oz bag) P/N 854893-13 for deliming. One 14 oz bag is required for C24EA3 & C24EA5 steamers.

- The cooling water supplied to the steamer is not treated. White vinegar poured down the cavity drains will prevent scale from forming in the drain system. Pour one cup (8 oz) of vinegar down each cavity drain at the end of the day 15 minutes after the unit has been turned off.

Hardness (Grains)	Generator Deliming Schedule with ScaleRelease	Drain Deliming Schedule with White Vinegar
0 to 5	6 Months	6 Months
5 to 10	3 Months	3 Months
10 to 15	Monthly	Monthly
15 to 20	2 Weeks	2 Weeks
20+	Other Water Treatment Is Required	Weekly

DELIMING THE GENERATOR

WARNING: READ AND FOLLOW THE INSTRUCTIONS ON THE DELIMING MATERIAL PACKAGE. AVOID CONTACT WITH SKIN AND EYES. WEAR PLASTIC OR RUBBER GLOVES AND SAFETY GOGGLES WHEN HANDLING. WASH THOROUGHLY AFTER HANDLING. IF DELIMING SOLUTION COMES IN CONTACT WITH THE SKIN OR EYES, RINSE THOROUGHLY WITH CLEAN WATER.

WARNING: THE STEAMER AND ITS PARTS ARE HOT. USE CARE WHEN OPERATING, CLEANING OR SERVICING THE STEAMER. THE COOKING COMPARTMENT CONTAINS LIVE STEAM. STAY CLEAR WHEN OPENING DOOR.

Items required (not provided)

ScaleRelease deliming material.

Funnel

Plastic or rubber gloves

Safety goggles or face shield

Measuring cup

1 gallon container for mixing deliming solution

Petrol-Gel Lubricant or equivalent food grade grease for coating deliming port threads

NOTE: Deliming solution may cause the surface of aluminum measuring tools to tarnish or etch.

NOTE: This procedure is not intended to take the place of a water treatment program.

Use instructions supplied with ScaleBlocker PM Kit when filter is being replaced.

Deliming

1. Turn power switch off. Wait 10 minutes for steam generator to completely drain and the drain valve to close. Visually verify the steamer is draining.
2. Close the compartment door and turn the timer off.
3. Prepare deliming solution according to the instructions on the deliming material package. Follow all manufacturers' instructions.
4. Remove delime port cap on top of unit and insert funnel into delime port.

Caution: The deliming cap will be hot. Use glove to open cap.

5. Pour deliming solution into the steam generator slowly to avoid spillage.
6. Remove funnel from delime port then rinse port with clean water.
7. Lightly coat the de-lime port threads with Petrol-Gel then install delime port cap. Cap must be installed and tightened securely at all times.
8. Turn the steamer on.
9. After 40 minutes, turn cooking timers on for 15 minutes to delime the steam tubes and nozzles.
10. After the buzzer sounds turn the unit off. Allow the generator to completely drain for 10 minutes. Visually verify the steamer is draining.

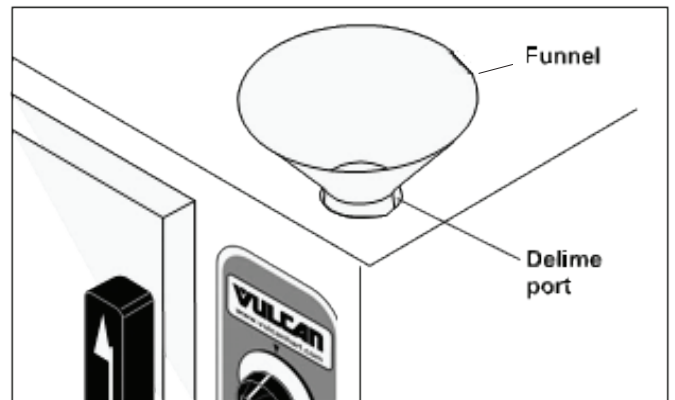

Rinsing Steam Generator After Delime

1. Turn the steamer back on and set the timer for 5 minutes.
2. When the timer buzzes turn the unit back off and allow the steamer to drain for 10 minutes.
3. Turn cooking timers to off.
4. Repeat steam generator rinse one time.
5. Follow Daily Cleaning procedure.
6. The steamer is ready for operation or shutdown

For a complete Installation & Operation, Parts, and Service manuals please visit www.vulcanequipment.com/resource-center or scan QR code on right.

Vulcan Technical Support
1-800-814-2028 or email at steam.tech@itwfeg.com

