

MINI-STACK2 (VACM61KS)

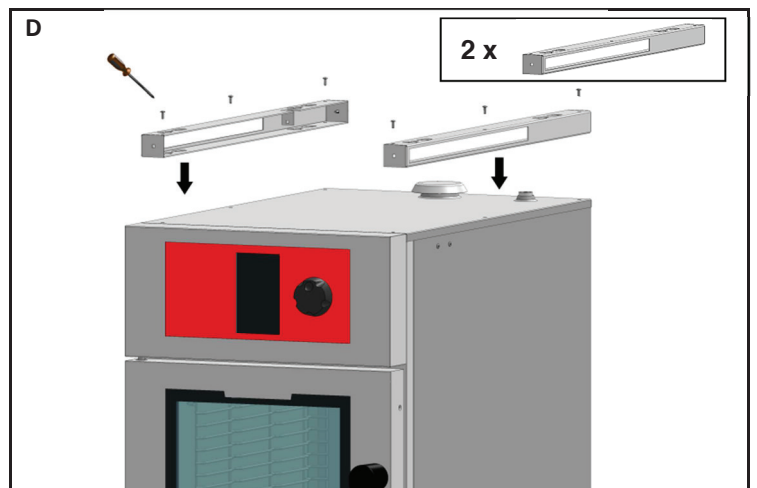

MINI-STACK2 (VACM61KS)

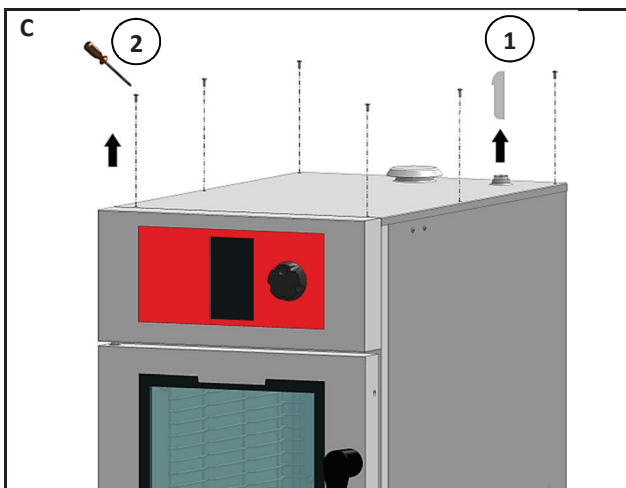
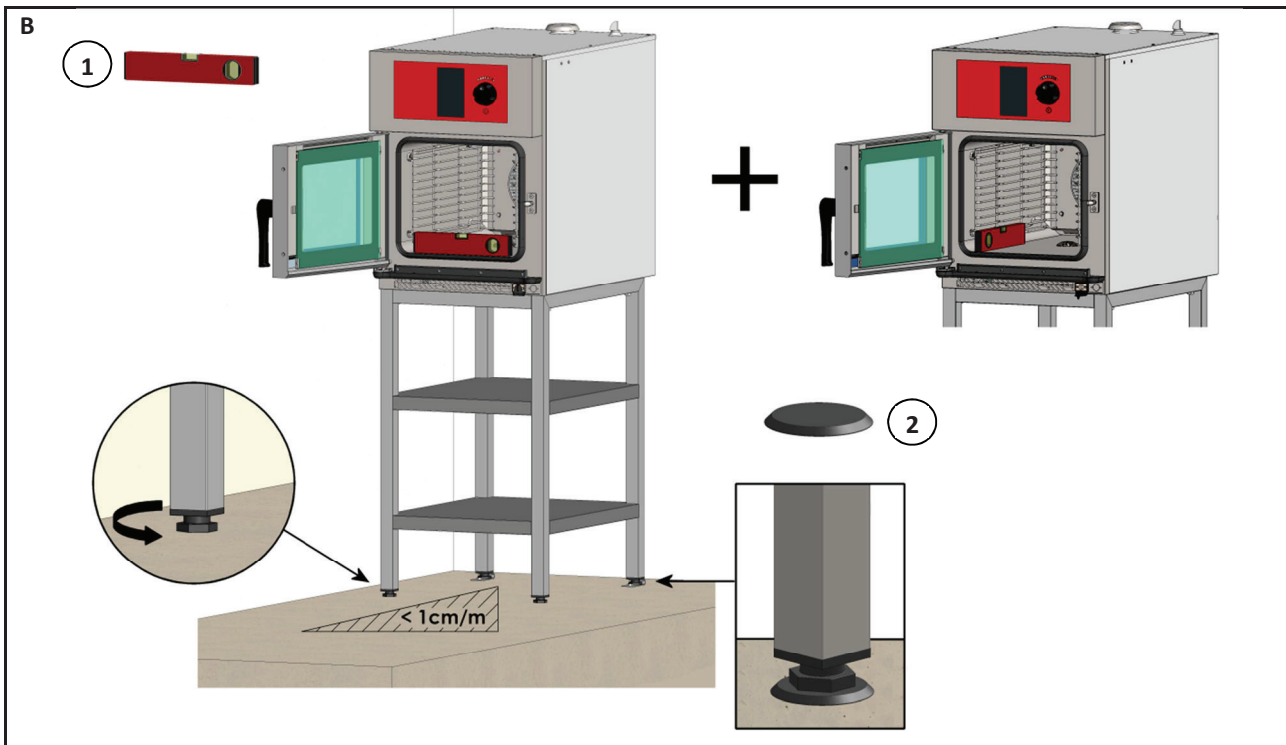
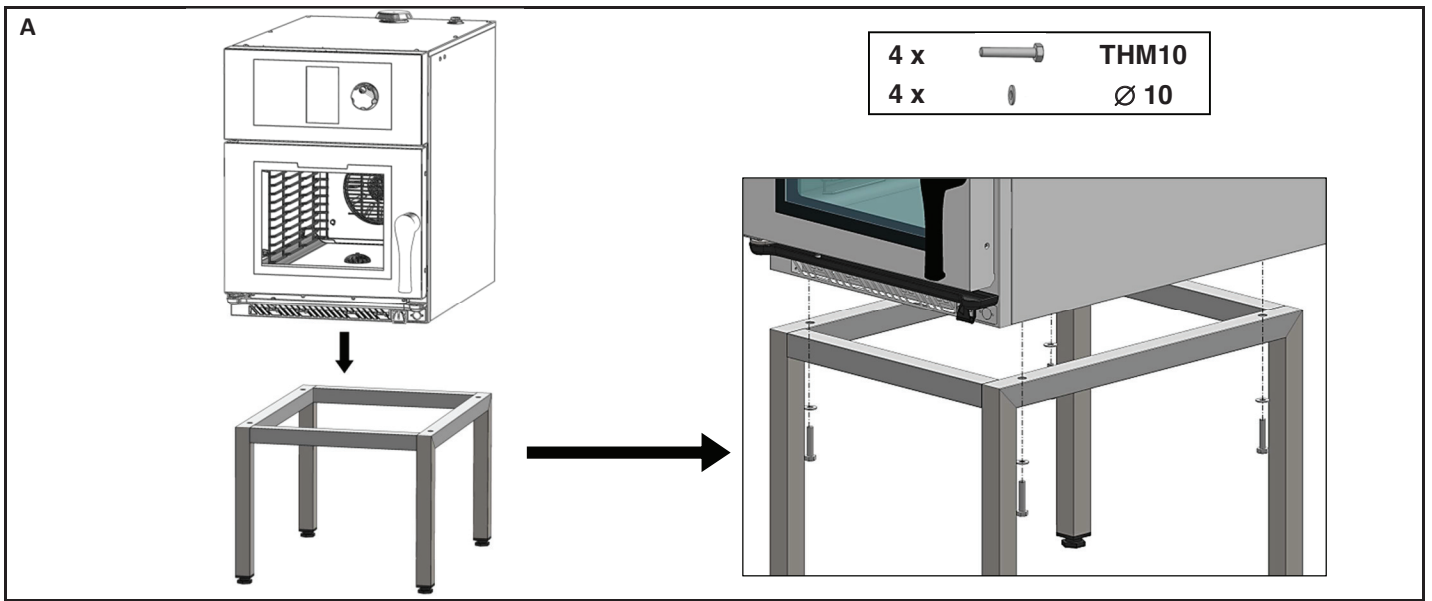
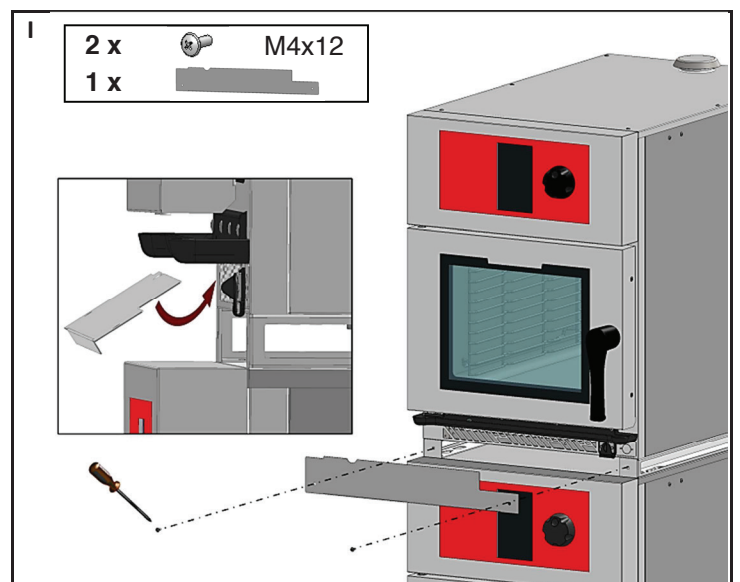
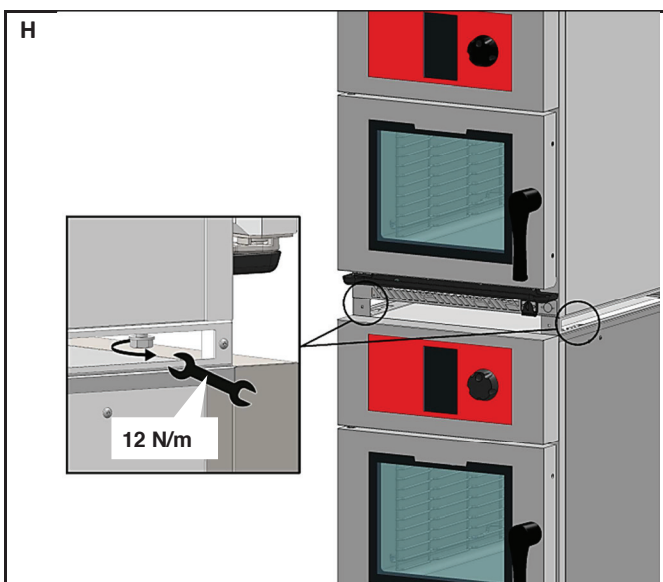
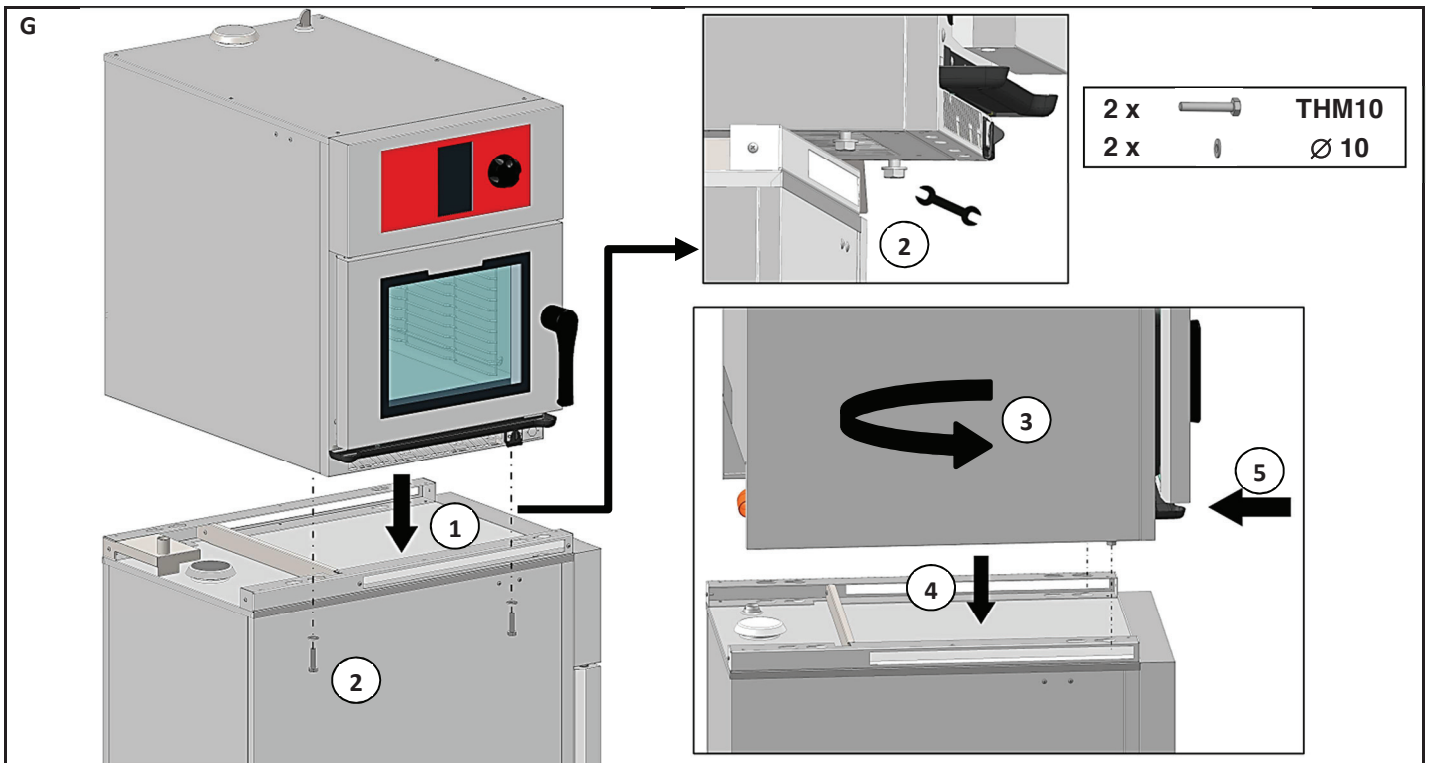
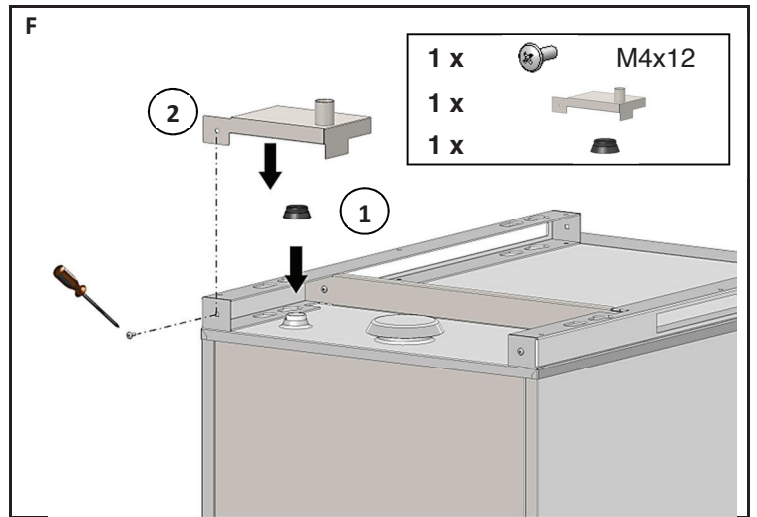
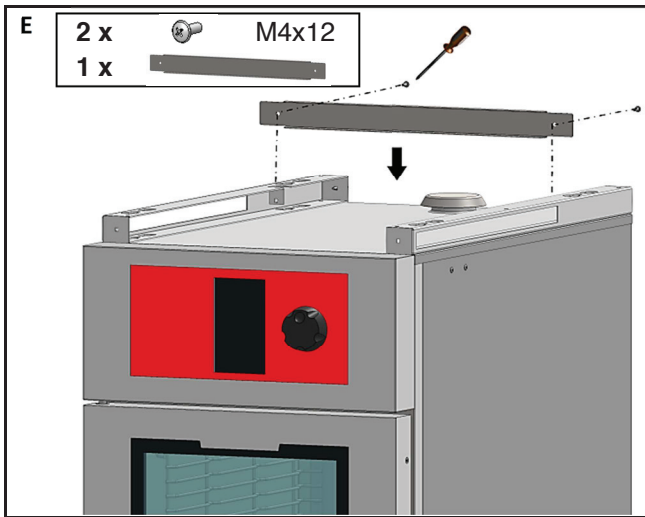

MINI-STACK2 (VACM61KS)

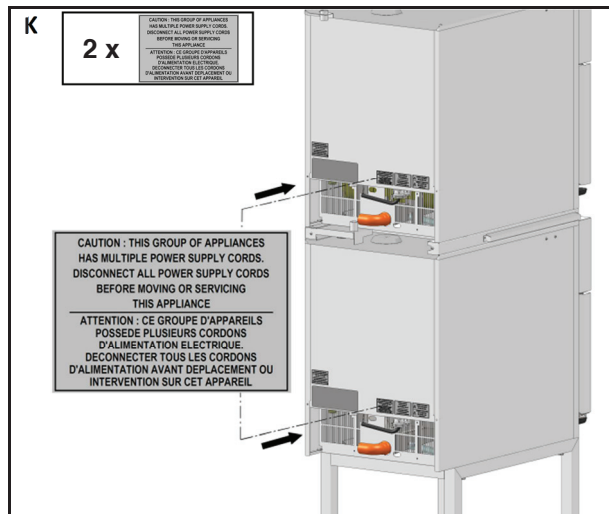
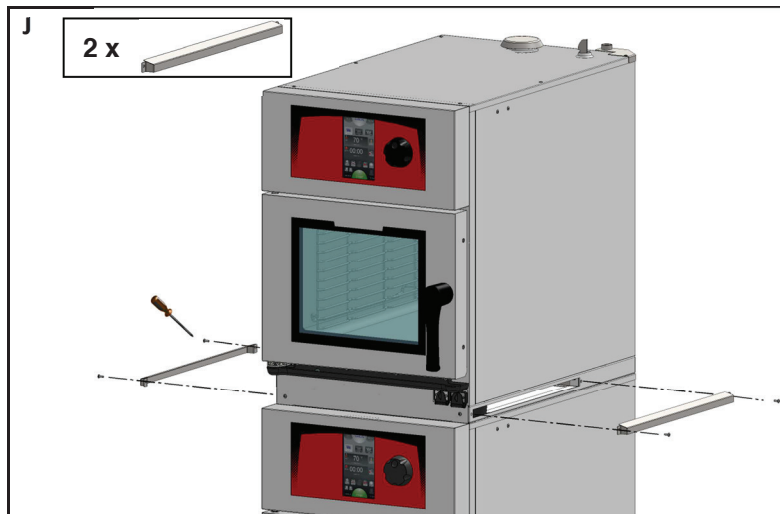

2 solutions : / 2 Lösungen : / 2 soluciones:

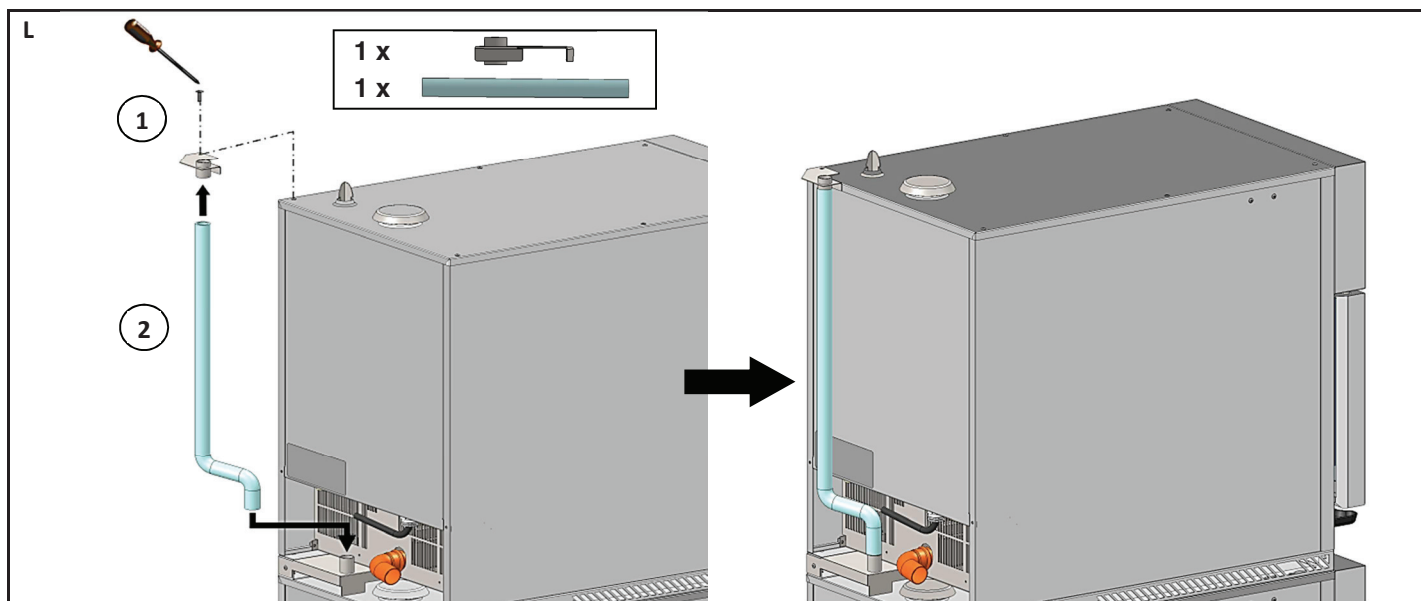

Ou / Or / Oder / O

